

4

3

2

1

THIS DRAWING IS UNPUBLISHED. RELEASED FOR PUBLICATION ,19 .  
 © COPYRIGHT 19 BY AMP INCORPORATED. ALL RIGHTS RESERVED.

LOC		DIST		REVISIONS			
P	LTR	DESCRIPTION		DATE	DWN	APVD	
	C	REVISED PER 0L20-0178-97		310CT97	DKS	CHK	

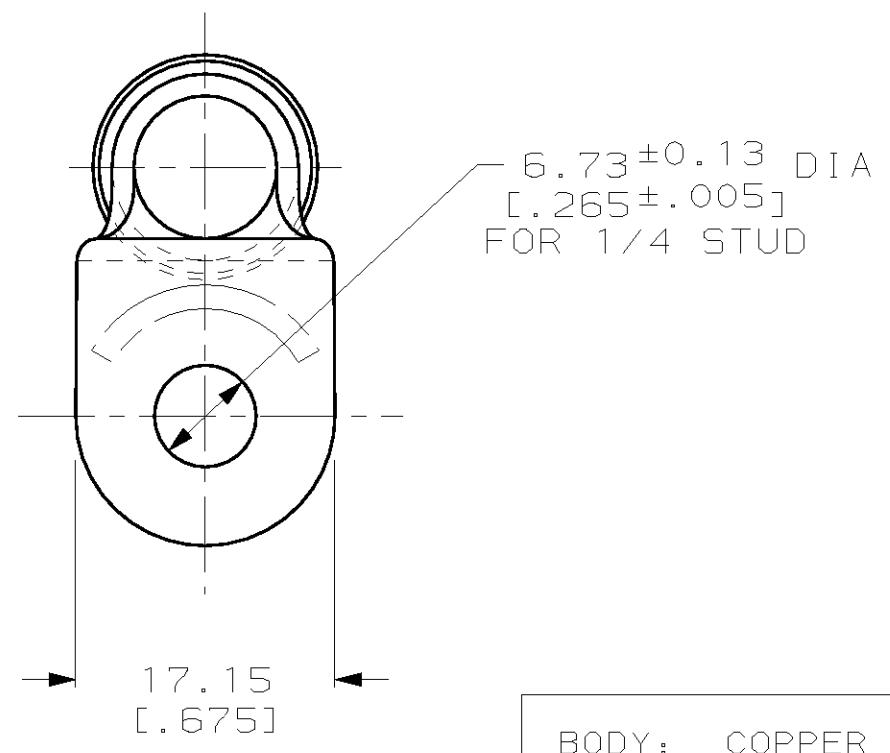
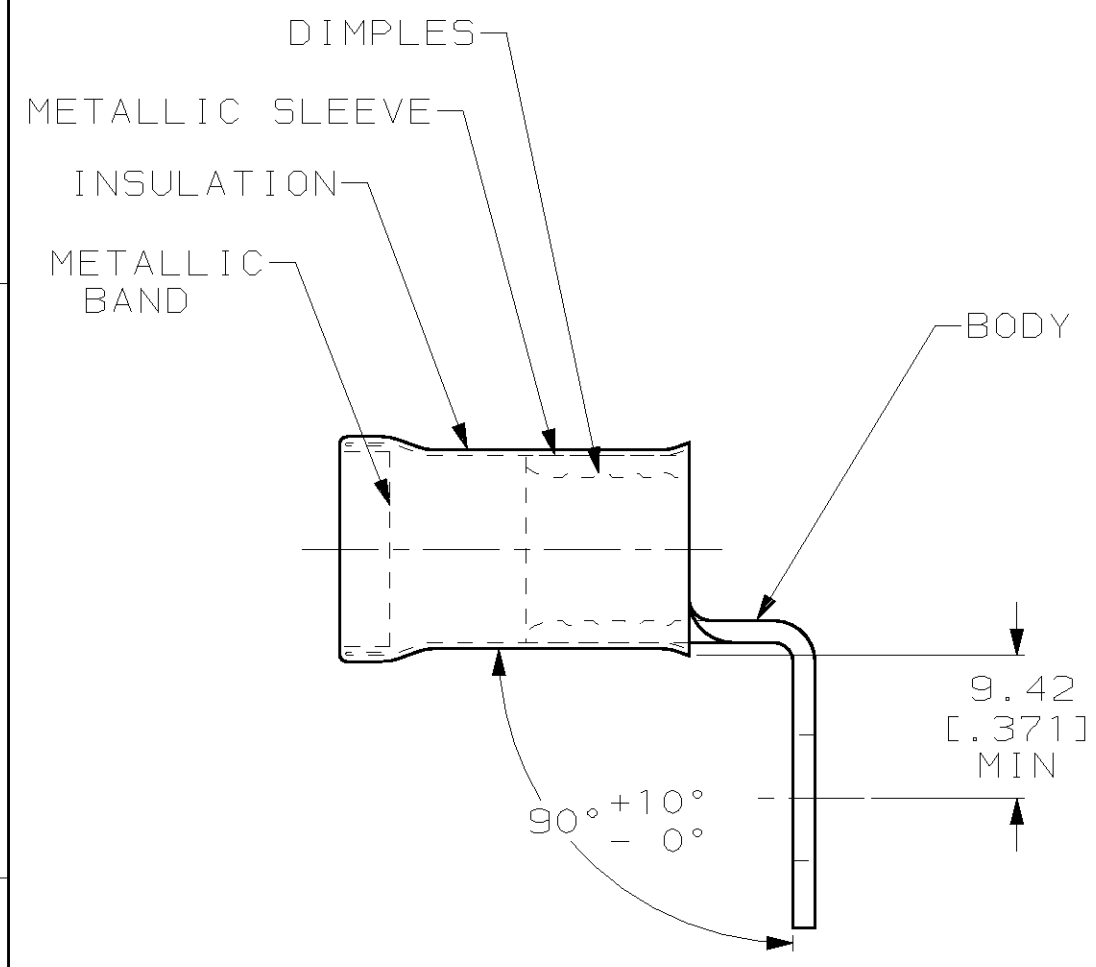

- 1 MATERIAL THK: 1.45 ± 0.08 [.057 ± .003]
- 2 WIRE INSULATION DIA: 12.83 [.505] MAX

<u>BODY:</u> COPPER PER ASTM B-152 TIN PL 0.00254 [.000100] MIN THK PER ASTM B-545	322900
<u>INSULATION:</u> PVC <u>COLOR:</u> RED	
<u>METALLIC SLEEVE:</u> COPPER PER ASTM B-152	
<u>METALLIC BAND:</u> STEEL PER ASTM A-109	
MATERIAL & FINISH	AMP PART NUMBER

## AMP INCORPORATED CUSTOMER SERVICE SYSTEMS

FOR ADDITIONAL PRODUCT INFORMATION OR COPIES OF DRAWINGS AND TECHNICAL DOCUMENTS	PRODUCT INFORMATION CENTER 1-800-522-6752	RECOMMENDED OPERATING TEMPERATURE: 105°C MAX
FOR APPLICATION TOOLING INFORMATION	TOOLING ASSISTANCE CENTER 1-800-722-1111	VOLTAGE RATING: NOT APPLICABLE
FOR ORDER ENTRY	1-800-526-5142	WIRE CROSS SECTIONAL AREA RANGE: 26.7-42.4mm <sup>2</sup> [52,600-83,700] CIR MILS SOLID OR STRANDED

THIS DRAWING IS A CONTROLLED DOCUMENT.

DIMENSIONS: mm [INCHES]	TOLERANCES UNLESS OTHERWISE SPECIFIED:	DWN DK SCHRUM 310CT97	CHK MJ SPICER 03NOV97	APVD JL MECKLEY 03NOV97	AMP Incorporated Harrisburg, PA 17105-3608
	0 PLC ±-	<b>AMP</b> NAME TERMINAL, RING TONGUE, BENT 90°, AMPLI-BOND™, WIRE SIZE: 2 AWG			
	1 PLC ±-				
	2 PLC ±0.20 [.008]	PRODUCT SPEC	SIZE	CAGE CODE	DRAWING NO
	3 PLC ±-	APPLICATION SPEC	A3 00779 C- 322900		
	4 PLC ±-	WEIGHT	RESTRICTED TO		
	ANGLES ±-	CUSTOMER DRAWING	SCALE	SHEET	REV
MATERIAL SEE TABLE	FINISH SEE TABLE		2:1	1 OF 1	C