

SERPAC 094 (exploded isometric)

Electronic Enclosures

- Click on image to show toolbar. Use ▶ || to Play/Pause Animation.
- Left click and drag on image to move 3D model.

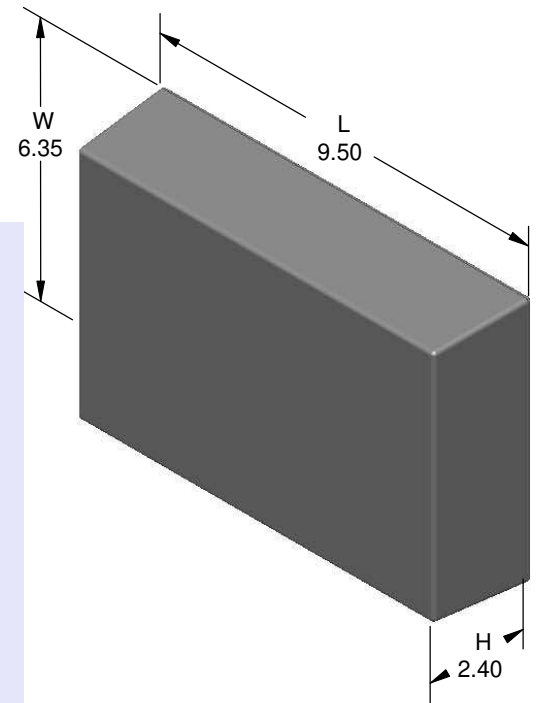
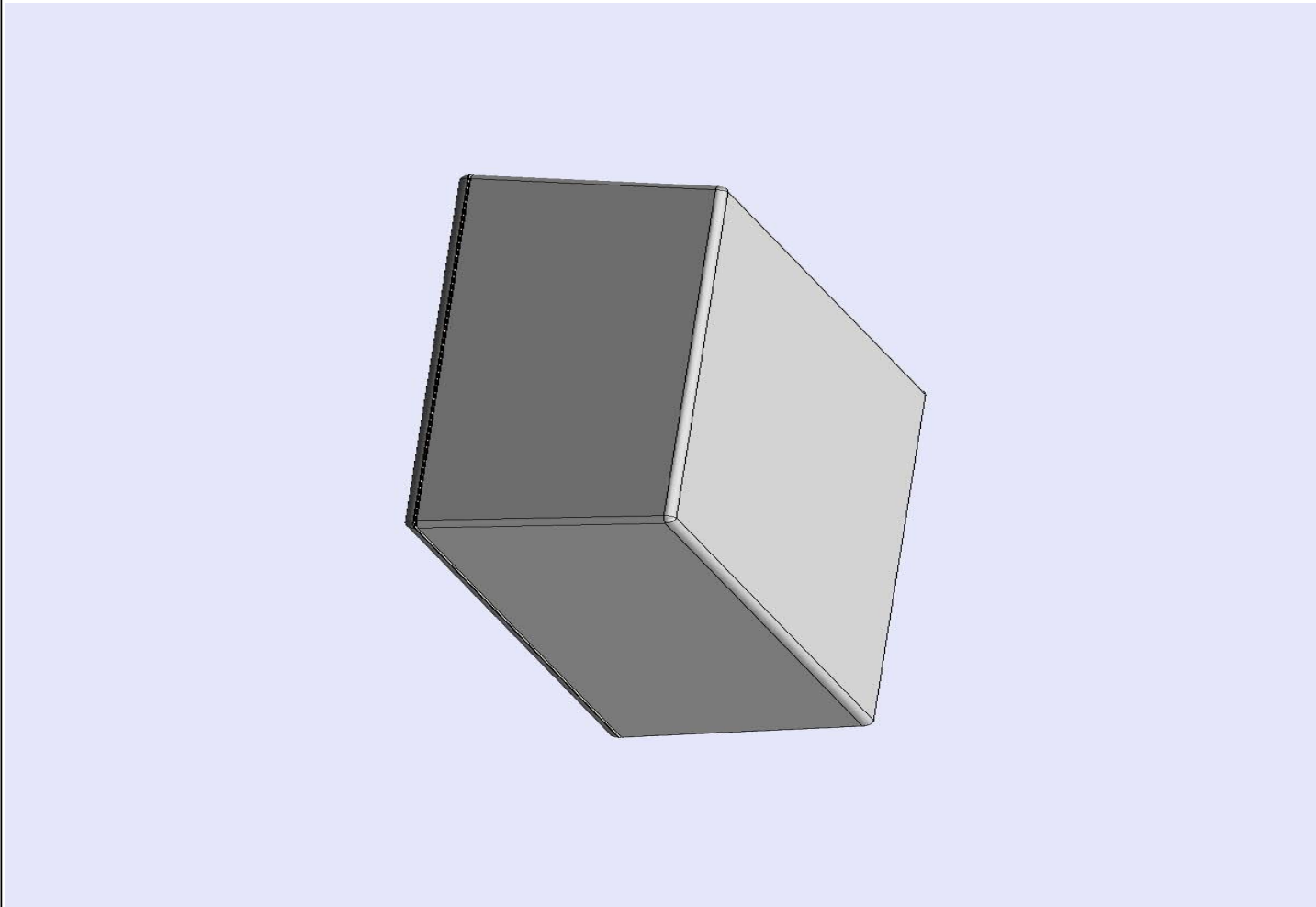

- a) Zoom in & out with center wheel.
- b) Pause at any moment to view and or print views.
- c) Change the views to ortho and section views if needed from the Views pull down menu.
- d) Explore options included in the tool bar like: Views, Transparency of model, Lighting type, etc.

PART NO.	DESCRIPTION (Included)	ACCESSORIES (Optional)	
9-4	TOP	PART NO.	DESCRIPTION
09	BOTTOM	51	Non-skid Feet
6005	#4X3/8" Self tapping (6)		

Notes: Enclosure weight .69 lbs/ 312 gm
 1) Enclosure meets or exceeds IP40 and NEMA 1
 2) Circuit Board drawings can be download at:
http://www.serpac.com/Products/Sseries/x9x/drawings/09X_top-CB.pdf
 3) All components are RoHS Compliant.

ALL DIMENSIONS ARE ±.010" 3/18/10 (1 of 2)
619 Commercial Ave. Covina, CA 91723
 Ph. (626) 331-0517 Fx. (626) 331-8584 serpac.com

SERPAC 094 (user print)

Electronic Enclosures

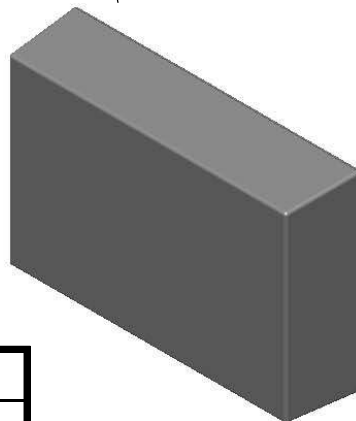
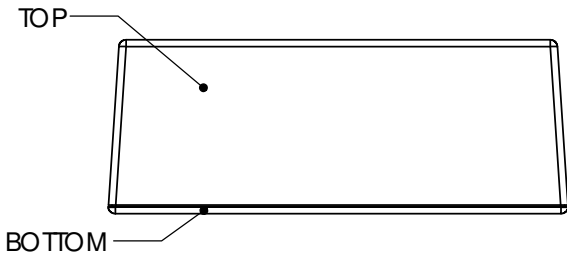
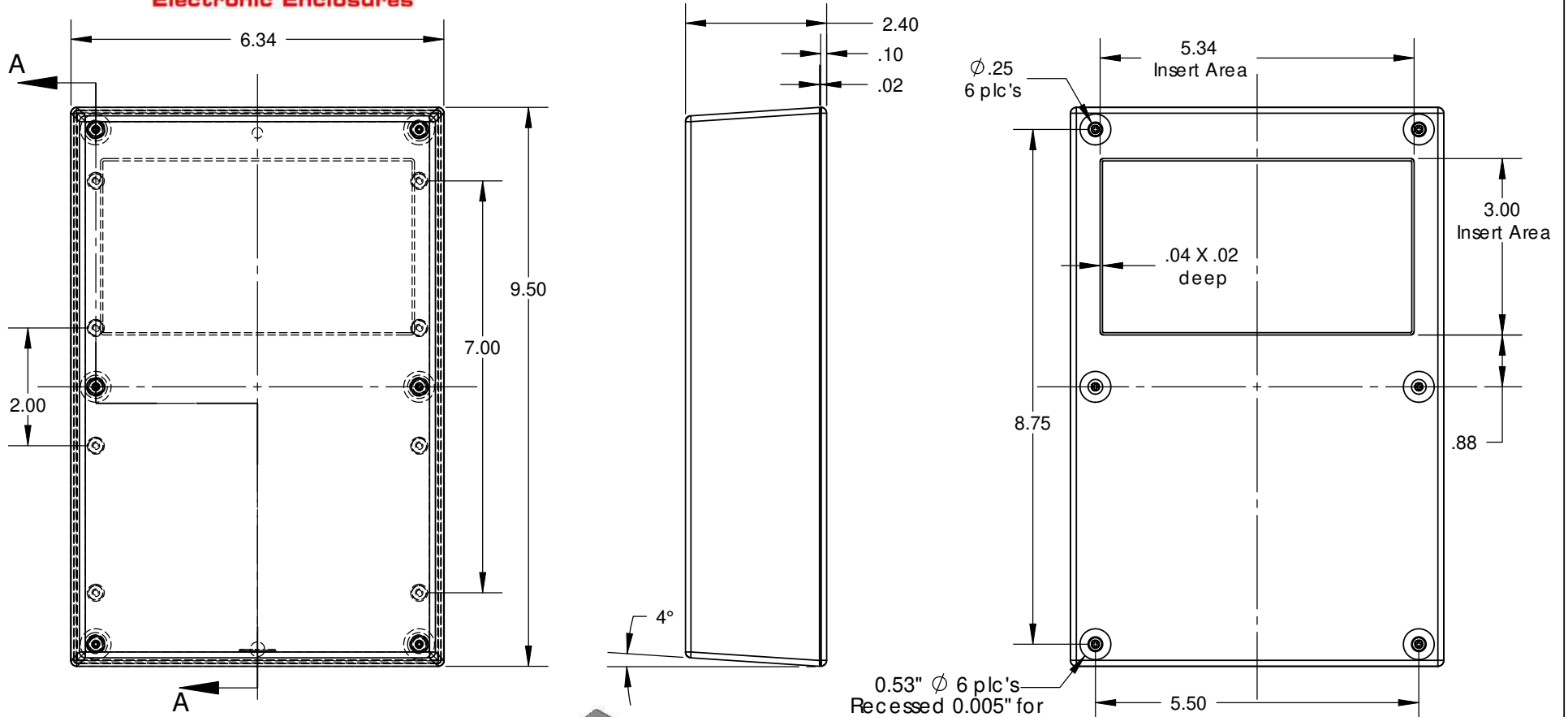

0.53" ϕ 6 plc's
Recessed 0.005" for
Non-skid feet
(not included)

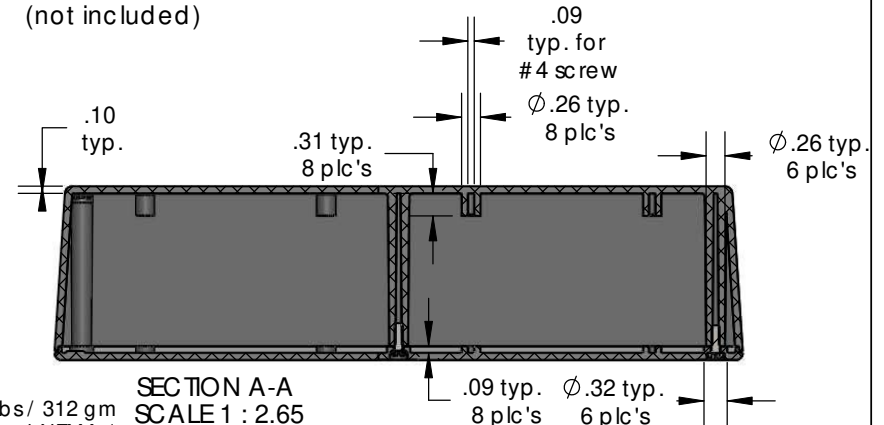

SECTION A-A
SCALE 1 : 2.65

PART NO.	DESCRIPTION (Included)	ACCESSORIES (Optional)	
9-4	TOP	PART NO.	DESCRIPTION
09	BOTTOM	51	Non-skid Feet
6005	#4X3/8" Self tapping (6)		

Notes: Enclosure weight .69 lbs / 312 gm
 1) Enclosure meets or exceeds IP40 and NEMA 1
 2) Circuit Board drawings can be download at:
http://www.serpac.com/Products/series/x9x/drawings/09X_top-CB.pdf
 3) All components are RoHS Compliant.