



Precision, Low-Voltage Analog Switches

MAX381/MAX383/MAX385

General Description

The MAX381/MAX383/MAX385 are precision, low-voltage analog switches. The single-pole single-throw MAX381 and double-pole single-throw MAX385 dual switches are normally open. The single-pole double-throw MAX383 has two normally open and two normally closed poles. All three parts offer low on-resistance (less than 35Ω), guaranteed to match to within 2Ω between channels and to remain flat over the specified analog signal range (4Ω max). They also offer low leakage (less than 250pA at +25°C and less than 2.5nA at +85°C) and fast switching (turn-on time less than 175ns and turn-off time less than 100ns).

The MAX381/MAX383/MAX385 are fabricated with Maxim's low-voltage silicon-gate process for high system accuracy. Design improvements guarantee extremely low charge injection (<5pC) and low power consumption (<10μW).

These monolithic switches operate with a single positive supply (+3V to +15V) or with split supplies (±3V to ±8V) while retaining CMOS-logic input compatibility and fast switching. CMOS inputs provide reduced input loading.

Applications

Sample-and-Hold Circuits	Military Radios
Test Equipment	Communication Systems
Heads-Up Displays	Battery-Operated Systems
Audio Signal Routing	PBX, PABX
Guidance and Control Systems	

Features

- ◆ Single-Supply Operation (+3V to +15V)
Bipolar-Supply Operation (±3V to ±8V)
- ◆ Pin-Compatible with DG401/DG403/DG405
- ◆ Low On-Resistance, 20Ω Typical (35Ω Max)
- ◆ Guaranteed Matched On-Resistance Between Channels, <2Ω
- ◆ Guaranteed Flat On-Resistance over Specified Analog Signal Range, <4Ω
- ◆ Guaranteed Charge Injection, <5pC
- ◆ Guaranteed Off-Channel Leakage, <2.5nA at +85°C
- ◆ TTL/CMOS-Logic Compatible with 3V, 5V, ±3V, and ±5V Supplies
- ◆ Rail-to-Rail Analog Signal Handling Capability

Ordering Information

PART	TEMP. RANGE	PIN-PACKAGE
MAX381CPE	0°C to +70°C	16 Plastic DIP
MAX381CSE	0°C to +70°C	16 Narrow SO
MAX381C/D	0°C to +70°C	Dice*
MAX381EPE	-40°C to +85°C	16 Plastic DIP
MAX381ESE	-40°C to +85°C	16 Narrow SO
MAX381EJE	-40°C to +85°C	16 CERDIP**
MAX381MJE	-55°C to +125°C	16 CERDIP**

Ordering Information continued on last page.

* Dice are tested at $T_A = +25^\circ\text{C}$ only.

** Contact factory for package availability.

Pin Configurations/Block Diagrams/Truth Tables

TOP VIEW

MAX381	
LOGIC IN	SWITCH
0	OFF
1	ON
PWR OFF	OFF

MAX383			
LOGIC IN	COM	NC	NO
0	NC	COM	OFF
1	NO	OFF	COM
PWR OFF	OFF	OFF	OFF

MAX385	
LOGIC IN	COM, NO
0	OFF
1	ON
PWR OFF	OFF

N.C. = NOT INTERNALLY CONNECTED



Precision, Low-Voltage Analog Switches

ABSOLUTE MAXIMUM RATINGS

Voltage Referenced to GND

V+	-0.3V to +17V
V-	+0.3V to -17V
V+ to V-	-0.3V to +17V
COM, NO, NC, IN	(V- - 2V) to (V+ + 2V) or 30mA, whichever occurs first

Continuous Current, any pin	30mA
Peak Current, any pin (pulsed at 1ms, 10% duty cycle max)	100mA

Continuous Power Dissipation (T_A = +70°C)

Plastic DIP (derate 10.53mW/°C above +70°C)	842mW
Narrow SO (derate 8.70mW/°C above +70°C)	696mW
CERDIP (derate 10.00mW/°C above +70°C)	800mW

Operating Temperature Ranges

MAX38_C_E	0°C to +70°C
MAX38_E_E	-40°C to +85°C
MAX38_MJE	-55°C to +125°C
Storage Temperature Range	-65°C to +150°C
Lead Temperature (soldering, 10sec)	+300°C

Note 1: Signals on NC, NO, COM, or IN exceeding V+ or V- are clamped by internal diodes. Limit forward diode current to maximum current rating.

Stresses beyond those listed under "Absolute Maximum Ratings" may cause permanent damage to the device. These are stress ratings only, and functional operation of the device at these or any other conditions beyond those indicated in the operational sections of the specifications is not implied. Exposure to absolute maximum rating conditions for extended periods may affect device reliability.

ELECTRICAL CHARACTERISTICS—Dual Supplies

(V+ = +5V ±10%, V- = -5V ±10%, GND = 0V, V_{INH} = 2.4V, V_{INL} = 0.8V, T_A = T_{MIN} to T_{MAX}, unless otherwise noted.)

PARAMETER	SYMBOL	CONDITIONS	TEMP. RANGE	MIN	TYP (Note 2)	MAX	UNITS	
SWITCH								
Analog Signal Range	V _{COM} , V _{NO} , V _{NC}	(Note 3)		V-		V+	V	
On-Resistance	R _{ON}	V+ = 4.5V, V- = -4.5V, V _{NC} or V _{NO} = ±3.5V, I _{COM} = -10mA, V _{INH} = 2.4V, V _{INL} = 0.8V	T _A = +25°C	C, E	20	35	Ω	
			T _A = T _{MIN} to T _{MAX}	M	20	30		
On-Resistance Match Between Channels (Note 4)	ΔR _{ON}	V _{NC} or V _{NO} = ±3V, I _{COM} = -10mA, V+ = 5V, V- = -5V	T _A = +25°C	C, E, M	0.5	2	Ω	
			T _A = T _{MIN} to T _{MAX}	C, E, M		4		
On-Resistance Flatness (Note 4)	R _{FLAT(ON)}	V _{NC} or V _{NO} = 3V, 0V, -3V; I _{COM} = -10mA, V+ = 5V; V- = -5V	T _A = +25°C	C, E, M		4	Ω	
			T _A = T _{MIN} to T _{MAX}	C, E, M		6		
NC or NO Off Leakage Current (Note 5)	I _{NC(OFF)} or I _{NO(OFF)}	V _{COM} = ±4.5V, V _{NC} or V _{NO} = ±4.5V, V+ = 5.5V, V- = -5.5V	T _A = +25°C	C, E	-0.2	-0.01	0.2	nA
			T _A = +25°C	M	-0.1	-0.01	0.1	
			T _A = T _{MIN} to T _{MAX}	C, E	-2.5		2.5	
			T _A = T _{MIN} to T _{MAX}	M	-5.0		5.0	
COM Off Leakage Current (Note 5)	I _{COM(OFF)}	V _{COM} = ±4.5V, V _{NC} or V _{NO} = ±4.5V, V+ = 5.5V, V- = -5.5V	T _A = +25°C	C, E	-0.2	-0.01	0.2	nA
			T _A = +25°C	M	-0.1	-0.01	0.1	
			T _A = T _{MIN} to T _{MAX}	C, E	-2.5		2.5	
			T _A = T _{MIN} to T _{MAX}	M	-5.0		5.0	
COM On Leakage Current (Note 5)	I _{COM(ON)}	V _{COM} = ±4.5V, V _{NC} or V _{NO} = ±4.5V, V+ = 5.5V, V- = -5.5V	T _A = +25°C	C, E	-0.4	-0.04	0.4	nA
			T _A = +25°C	M	-0.2	-0.04	0.2	
			T _A = T _{MIN} to T _{MAX}	C, E	-5.0		5.0	
			T _A = T _{MIN} to T _{MAX}	M	-20.0		20.0	

Precision, Low-Voltage Analog Switches

MAX381/MAX383/MAX385

ELECTRICAL CHARACTERISTICS—Dual Supplies (continued)

(V₊ = +5V ±10%, V₋ = -5V ±10%, GND = 0V, V_{INH} = 2.4V, V_{INL} = 0.8V, T_A = T_{MIN} to T_{MAX}, unless otherwise noted.)

PARAMETER	SYMBOL	CONDITIONS		MIN	TYP (Note 2)	MAX	UNITS
DIGITAL LOGIC INPUT							
Input Current with Input Voltage High	I _{INH}	V _{IN} = 2.4V, all others = 0.8V		-1.0	0.005	1.0	μA
Input Current with Input Voltage Low	I _{INL}	V _{IN} = 0.8V, all others = 2.4V		-1.0	0.005	1.0	μA
Logic High Input Voltage	V _{AH}		T _A = T _{MIN} to T _{MAX}	2.4			V
Logic Low Input Voltage	V _{AL}		T _A = T _{MIN} to T _{MAX}			0.8	V
DYNAMIC							
Turn-On Time	t _{ON}	V _{COM} = 3V, Figure 2	T _A = +25°C	100	175		ns
			T _A = T _{MIN} to T _{MAX}	225			
Turn-Off Time	t _{OFF}	V _{COM} = 3V, Figure 2	T _A = +25°C	60	100		ns
			T _A = T _{MIN} to T _{MAX}	150			
Break-Before-Make Time Delay (Note 3)	t _D	MAX383 only, Figure 3	T _A = +25°C	10	20		ns
Charge Injection (Note 3)	V _{CTE}	C _L = 1.0nF, V _{GEN} = 0V, R _{GEN} = 0Ω, Figure 4	T _A = +25°C		2	5	pC
Off Isolation (Note 6)	V _{ISO}	R _L = 100Ω, C _L = 5pF, f = 1MHz, Figure 5	T _A = +25°C		72		dB
Crosstalk (Note 7)	V _{CT}	R _L = 50Ω, C _L = 5pF, f = 1MHz, Figure 6	T _A = +25°C		90		dB
Off Capacitance	C _{OFF}	f = 1MHz, Figure 7	T _A = +25°C		12		pF
COM Off Capacitance	C _{COM(OFF)}	f = 1MHz, Figure 7	T _A = +25°C		12		pF
Channel On Capacitance	C _{COM(ON)}	f = 1MHz, Figure 8	T _A = +25°C		39		pF
SUPPLY							
Power-Supply Range				±3		±8	V
Positive Supply Current	I ₊	All channels on or off, V ₊ = 5.5V, V ₋ = -5.5V, V _{IN} = 0V or V ₊		-1.0	0.06	1.0	μA
Negative Supply Current	I ₋	All channels on or off, V ₊ = 5.5V, V ₋ = -5.5V, V _{IN} = 0V or V ₊		-1.0	-0.01	1.0	μA

Note 2: The algebraic convention, where the most negative value is a minimum and the most positive value a maximum, is used in this data sheet.

Note 3: Guaranteed by design.

Note 4: ΔR_{ON} = ΔR_{ON(max)} - ΔR_{ON(min)}. On-resistance match between channels and flatness are guaranteed only with specified voltages. Flatness is defined as the difference between the maximum and minimum value of on-resistance as measured over the specified analog signal range.

Note 5: Leakage parameters are 100% tested at maximum rated hot temperature and guaranteed by correlation at room temperature.

Note 6: See Figure 4. Off isolation = 20log₁₀ V_{COM}/V_{NC} or V_{NO}. V_{COM} = output, V_{NC} or V_{NO} = input to off switch.

Note 7: Between any two switches. See Figure 5.

Note 8: Leakage testing at single supply is guaranteed by testing with dual supplies.

Precision, Low-Voltage Analog Switches

MAX381/MAX383/MAX385

ELECTRICAL CHARACTERISTICS—Single +5V Supply

(V+ = +5V ± 10%, V- = 0V, GND = 0V, VINH = 2.4V, VINL = 0.8V, TA = TMIN to TMAX, unless otherwise noted.)

PARAMETER	SYMBOL	CONDITIONS	TEMP. RANGE	MIN	TYP (Note 2)	MAX	UNITS	
SWITCH								
Analog Signal Range	V _{COM} , V _{NO} , V _{NC}	(Note 3)		0V		V+	V	
On-Resistance	R _{ON}	V+ = 5.0V, V- = 0V, V _{NC} or V _{NO} = 3.5V, I _{COM} = 1.0mA, V _{INH} = 2.4V, V _{INL} = 0.8V	T _A = +25°C	C, E	25	65	Ω	
			T _A = T _{MIN} to T _{MAX}	C, E, M		60		75
On-Resistance Match Between Channels (Note 4)	ΔR _{ON}	V _{NC} or V _{NO} = 3V, I _{COM} = 1.0mA, V+ = 5V	T _A = +25°C	C, E, M	0.5	2	Ω	
			T _A = T _{MIN} to T _{MAX}	C, E, M				4
On-Resistance Flatness (Note 4)	R _{FLAT(ON)}	V _{NC} or V _{NO} = 3V, 2V, 1V; I _{COM} = 1.0mA; V+ = 5V; V- = 0V	T _A = +25°C	C, E, M		6	Ω	
			T _A = T _{MIN} to T _{MAX}	C, E, M				8
NC or NO Off Leakage Current (Note 8)	I _{NC(OFF)} or I _{NO(OFF)}	V _{COM} = 0V, V _{NC} or V _{NO} = 4.5V, V+ = 5.5V, V- = 0V	T _A = +25°C	C, E	-0.2	-0.01	0.2	nA
				M	-0.1	-0.01	0.1	
			T _A = T _{MIN} to T _{MAX}	C, E	-2.5		2.5	
				M	-5.0		5.0	
COM Off Leakage Current (Note 8)	I _{COM(OFF)}	V _{COM} = 4.5V, V _{NC} or V _{NO} = 0V, V+ = 5.5V, V- = 0V	T _A = +25°C	C, E	-0.2	-0.01	0.2	nA
				M	-0.1	-0.01	0.1	
			T _A = T _{MIN} to T _{MAX}	C, E	-2.5		2.5	
				M	-5.0		5.0	
COM On Leakage Current (Note 8)	I _{COM(ON)}	V _{COM} = 4.5V, V _{NC} or V _{NO} = 4.5V, V+ = 5.5V, V- = 0V	T _A = +25°C	C, E	-0.4	-0.04	0.4	nA
				M	-0.2	-0.04	0.2	
			T _A = T _{MIN} to T _{MAX}	C, E	-5.0		5.0	
				M	-20.0		20.0	
DIGITAL LOGIC INPUT								
Input Current with Input Voltage High	I _{INH}	V _{IN} = 2.4V, all others = 0.8V		-1.0	0.005	1.0	μA	
Input Current with Input Voltage Low	I _{INL}	V _{IN} = 0.8V, all others = 2.4V		-1.0	0.005	1.0	μA	

Precision, Low-Voltage Analog Switches

MAX381/MAX383/MAX385

ELECTRICAL CHARACTERISTICS—Single +5V Supply (continued)

(V₊ = +5V ±10%, V₋ = 0V, GND = 0V, V_{INH} = 2.4V, V_{INL} = 0.8V, T_A = T_{MIN} to T_{MAX}, unless otherwise noted.)

PARAMETER	SYMBOL	CONDITIONS	MIN	TYP (Note 2)	MAX	UNITS
DYNAMIC						
Turn-On Time	t _{ON}	V _{COM} = 3V, Figure 2	T _A = +25°C	160	250	ns
			T _A = T _{MIN} to T _{MAX}		300	
Turn-Off Time	t _{OFF}	V _{COM} = 3V, Figure 2	T _A = +25°C	60	125	ns
			T _A = T _{MIN} to T _{MAX}		175	
Break-Before-Make Time Delay (Note 3)	t _D	MAX383 only	T _A = +25°C	10	20	ns
Charge Injection (Note 3)	V _{CTE}	C _L = 1.0nF, V _{GEN} = 0V, R _{GEN} = 0Ω	T _A = +25°C	2	5	pC
SUPPLY						
Power-Supply Range	V ₊		2.7		16	V
Positive Supply Current	I ₊	All channels on or off, V _{IN} = 0V or V ₊ , V ₊ = 5.5V, V ₋ = 0V	-1.0	0.01	1.0	μA
Negative Supply Current	I ₋	All channels on or off, V _{IN} = 0V or V ₊ , V ₊ = 5.5V, V ₋ = 0V	-1.0	-0.01	1.0	μA

ELECTRICAL CHARACTERISTICS—Single +3.3V Supply

(V₊ = 3.0V to 3.6V, GND = 0V, V_{INH} = 2.4V, V_{INL} = 0.8V, T_A = T_{MIN} to T_{MAX}, unless otherwise noted.)

PARAMETER	SYMBOL	CONDITIONS	TEMP. RANGE	MIN	TYP (Note 2)	MAX	UNITS	
SWITCH								
Analog Signal Range	V _{COM} , V _{NO} , V _{NC}	(Note 3)		0V		V ₊	V	
On-Resistance	R _{ON}	V ₊ = 3V, V ₋ = 0V, V _{NC} or V _{NO} = 1.5V, I _{COM} = 1.0mA, V _{INH} = 2.4V, V _{INL} = 0.8V	T _A = +25°C	C, E	75	185	Ω	
			T _A = T _{MIN} to T _{MAX}	M		175		
NC or NO Off Leakage Current (Note 8)	I _{NC(OFF)} or I _{NO(OFF)}	V _{COM} = 0V, V _{NC} or V _{NO} = 3V, V ₊ = 3.6V, V ₋ = 0V	T _A = +25°C	C, E	-0.2	-0.01	0.2	nA
			T _A = +25°C	M	-0.1	-0.01	0.1	
			T _A = T _{MIN} to T _{MAX}	C, E	-2.5		2.5	
			T _A = T _{MIN} to T _{MAX}	M	-5.0		5.0	
COM Off Leakage Current (Note 8)	I _{COM(OFF)}	V _{COM} = 3V, V _{NC} or V _{NO} = 0V, V ₊ = 3.6V, V ₋ = 0V	T _A = +25°C	C, E	-0.2	-0.01	0.2	nA
			T _A = +25°C	M	-0.1	-0.01	0.1	
			T _A = T _{MIN} to T _{MAX}	C, E	-2.5		2.5	
			T _A = T _{MIN} to T _{MAX}	M	-5.0		5.0	
COM On Leakage Current (Note 8)	I _{COM(ON)}	V _{COM} = 3V, V _{NC} or V _{NO} = 3V, V ₊ = 3.6V, V ₋ = 0V	T _A = +25°C	C, E	-0.4	-0.04	0.4	nA
			T _A = +25°C	M	-0.2	-0.04	0.2	
			T _A = T _{MIN} to T _{MAX}	C, E	-5.0		5.0	
			T _A = T _{MIN} to T _{MAX}	M	-20.0		20.0	

Precision, Low-Voltage Analog Switches

ELECTRICAL CHARACTERISTICS—Single +3.3V Supply (continued)

($V_+ = 3.0V$ to $3.6V$, $GND = 0V$, $V_{INH} = 2.4V$, $V_{INL} = 0.8V$, $T_A = T_{MIN}$ to T_{MAX} , unless otherwise noted.)

PARAMETER	SYMBOL	CONDITIONS		MIN	TYP (Note 2)	MAX	UNITS
DIGITAL LOGIC INPUT							
Input Current with Input Voltage High	I_{INH}	$V_{IN} = 2.4V$, all others = $0.8V$		-1.0	0.005	1.0	μA
Input Current with Input Voltage Low	I_{INL}	$V_{IN} = 0.8V$, all others = $2.4V$		-1.0	0.005	1.0	μA
DYNAMIC							
Turn-On Time (Note 3)	t_{ON}	$V_{COM} = 1.5V$, Figure 2	$T_A = +25^\circ C$			400	ns
Turn-Off Time (Note 3)	t_{OFF}	$V_{COM} = 1.5V$, Figure 2	$T_A = +25^\circ C$			150	ns
Break-Before-Make Time Delay (Note 3)	t_D	MAX383 only	$T_A = +25^\circ C$	10	20		ns
Charge Injection (Note 3)	V_{CTE}	$C_L = 1.0nF$, $V_{GEN} = 0V$, $R_{GEN} = 0\Omega$	$T_A = +25^\circ C$		1	5	pC
SUPPLY							
Power-Supply Range	V_+			2.7		16	V
Positive Supply Current	I_+	All channels on or off, $V_{IN} = 0V$ or V_+ , $V_+ = 3.6V$, $V_- = 0V$		-1.0	0.01	1.0	μA
Negative Supply Current	I_-	All channels on or off, $V_{IN} = 0V$ or V_+ , $V_+ = 3.6V$, $V_- = 0V$		-1.0	-0.01	1.0	μA

Typical Operating Characteristics

($T_A = +25^\circ C$, unless otherwise noted.)

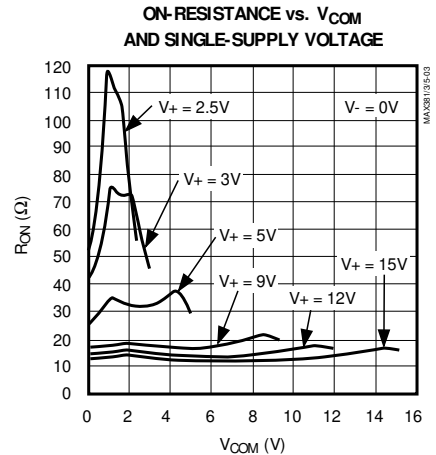
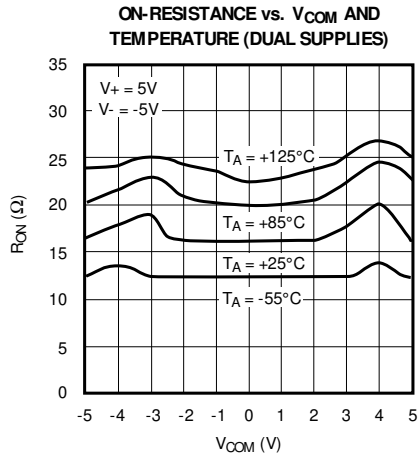
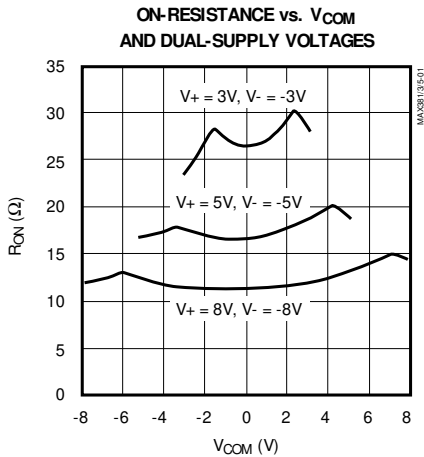

Precision, Low-Voltage Analog Switches

Typical Operating Characteristics (continued)

($T_A = +25^\circ\text{C}$, unless otherwise noted.)

MAX381/MAX383/MAX385

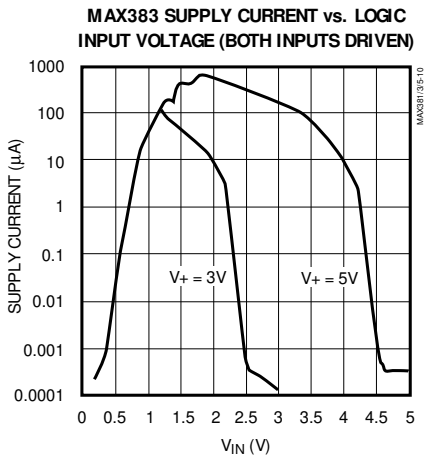
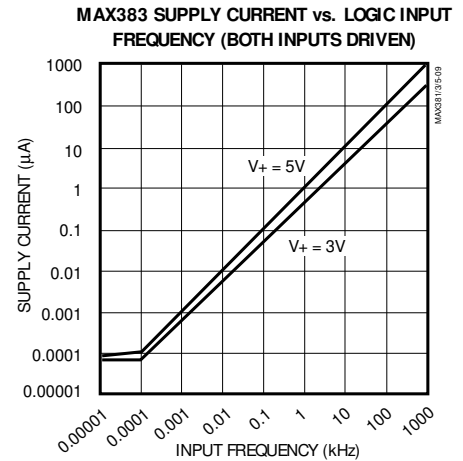
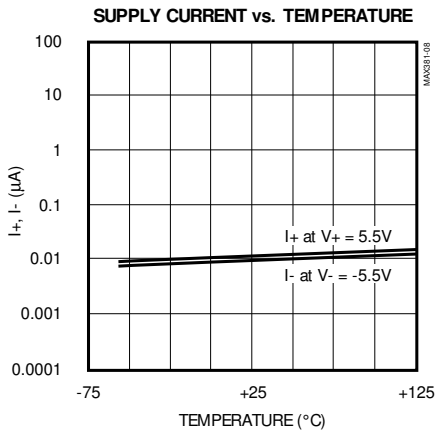
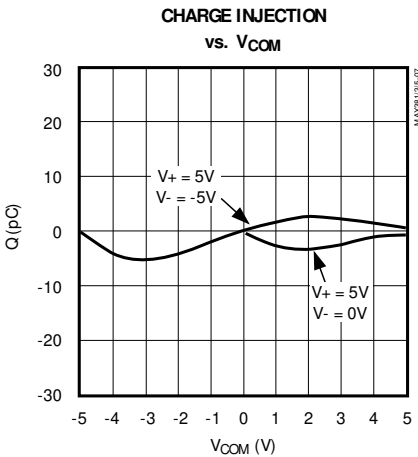
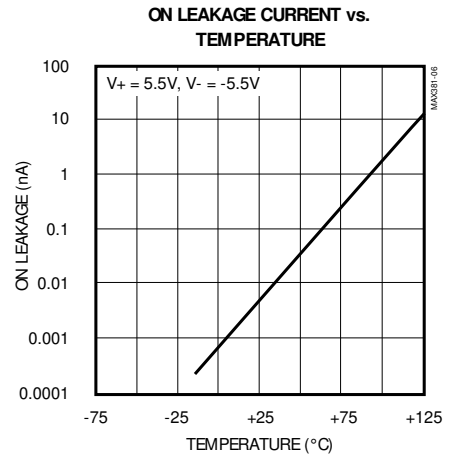
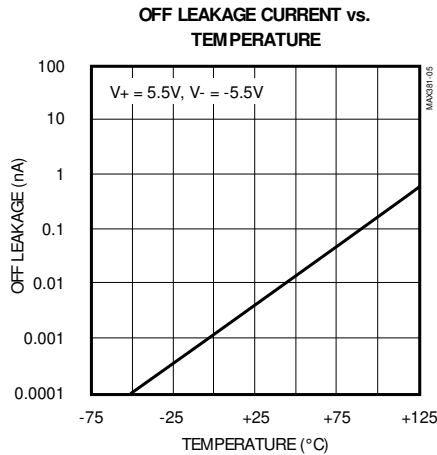
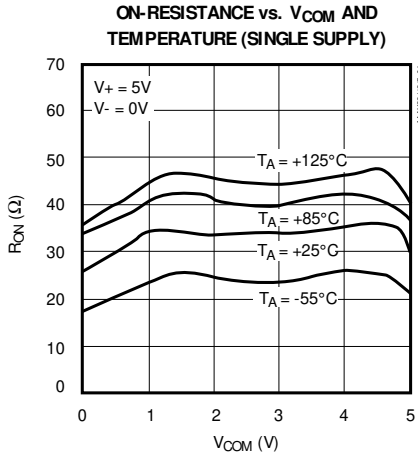

Precision, Low-Voltage Analog Switches

Pin Description

PIN			NAME	FUNCTION
MAX381	MAX383	MAX385		
1, 8	1, 3, 6, 8	1, 3, 6, 8	COM_	Analog Switch Common Terminal
2-7, 12	2, 7, 12	2, 7, 12	N.C.	Not Internally Connected
9, 16	9, 16	4, 5, 9, 16	NO_	Analog Switch Normally Open Terminal
—	4, 5	—	NC_	Analog Switch Normally Closed Terminal
10, 15	10, 15	10, 15	IN_*	Logic Level Input (Normally Low)
11	11	11	V+	Analog Signal and Logic Positive Supply Input
13	13	13	GND	Logic Negative Supply Input (Ground)
14	14	14	V-	Analog Signal Negative Supply Input

* IN1 controls COM1 and COM3; IN2 controls COM2 and COM4.

Applications Information

Operation with Supply Voltages Other than $\pm 5V$

The MAX381/MAX383/MAX385 switches operate with $\pm 3.0V$ to $\pm 8V$ bipolar supplies and a $+3V$ to $+15V$ single supply. In either case, analog signals ranging from $V+$ to $V-$ can be switched. The *Typical Operating Characteristics* graphs show the typical on-resistance variation with analog signal and supply voltage. The usual on-resistance temperature coefficient is $0.5\%/^{\circ}C$ (typ).

Overvoltage Protection

Proper power-supply sequencing is recommended for all CMOS devices. Do not exceed the absolute maximum ratings, because stresses beyond the listed ratings can cause permanent damage to the devices. Always sequence $V+$ on first, then $V-$, followed by the logic inputs, NO, or COM. If power-supply sequencing is not possible, add two small signal diodes ($D1$, $D2$) in series with supply pins for overvoltage protection (Figure 1). Adding diodes reduces the analog signal range to one diode drop below $V+$ and one diode drop above $V-$, but does not affect the devices' low switch resistance and low leakage characteristics. Device operation is unchanged, and the difference between $V+$ and $V-$ should not exceed $17V$. These protection diodes are not recommended when using a single $3V$ supply.

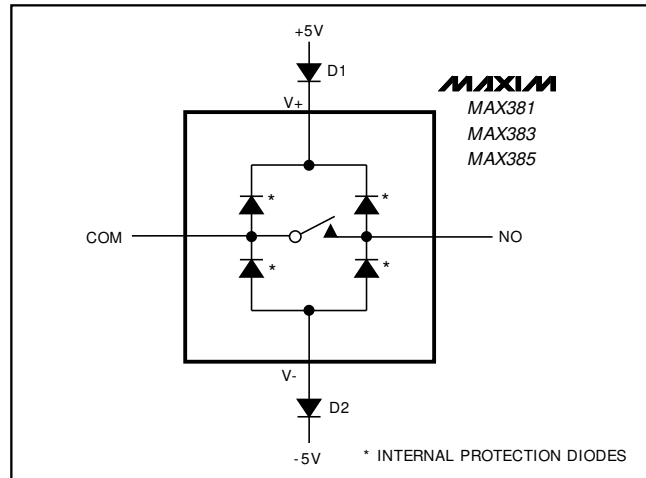

Figure 1. Overvoltage Protection Using Two External Blocking Diodes

Precision, Low-Voltage Analog Switches

Test Circuits/Timing Diagrams

MAX381/MAX383/MAX385

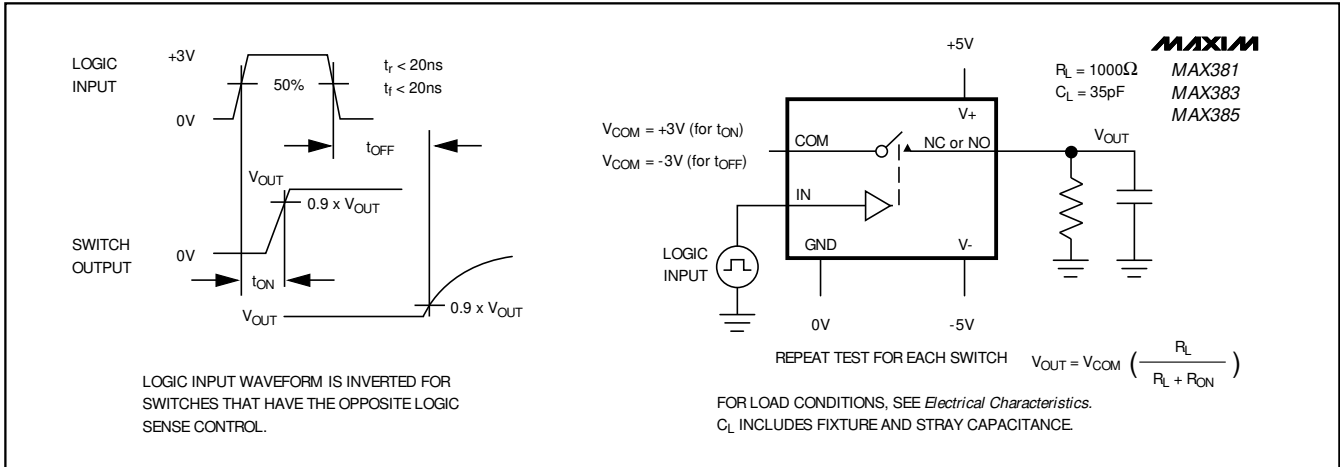

Figure 2. Switching-Time Test Circuit

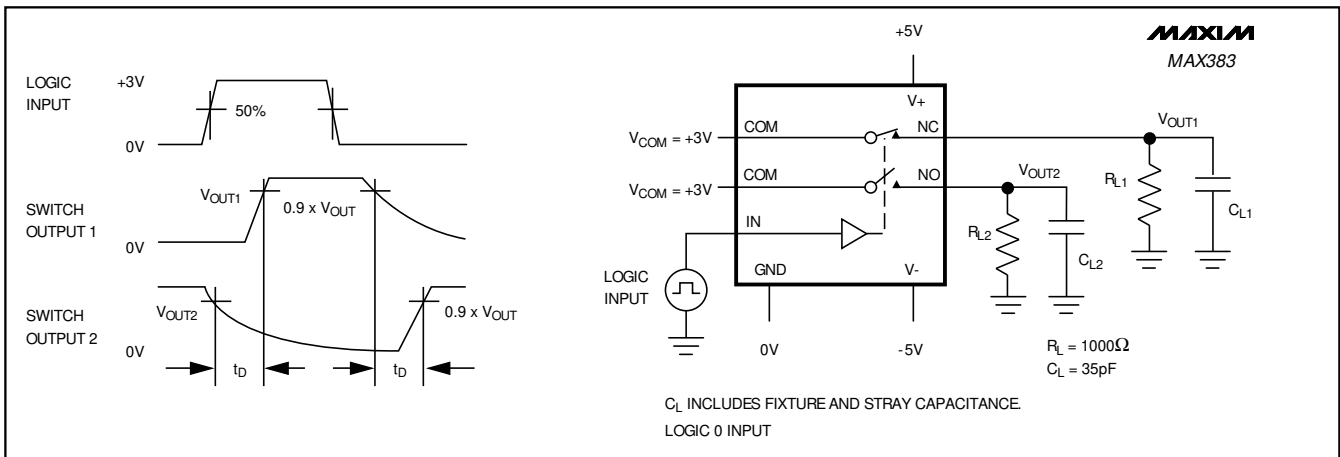

Figure 3. Break-Before-Make Test Circuit (MAX383 only)

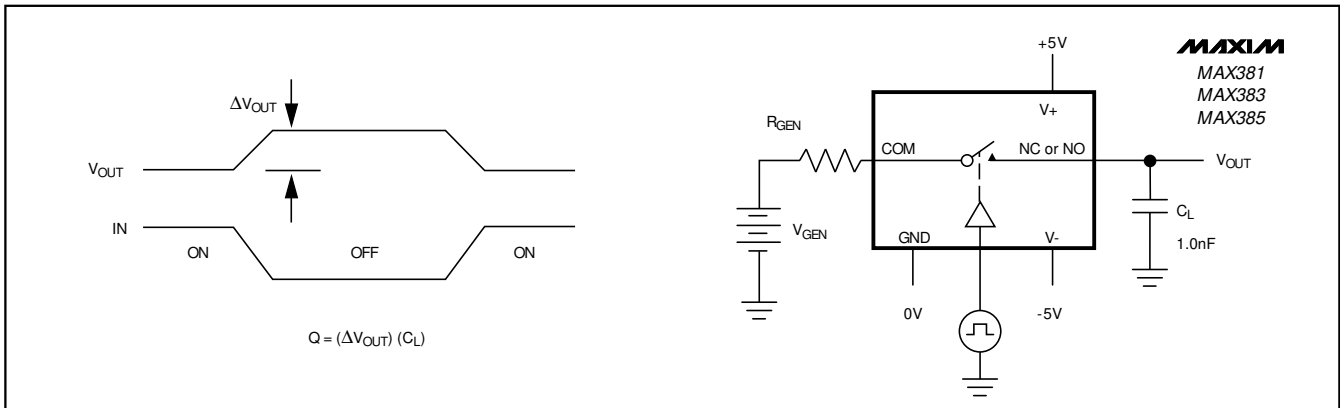

Figure 4. Charge-Injection Test Circuit

Precision, Low-Voltage Analog Switches

Test Circuits/Timing Diagrams (continued)

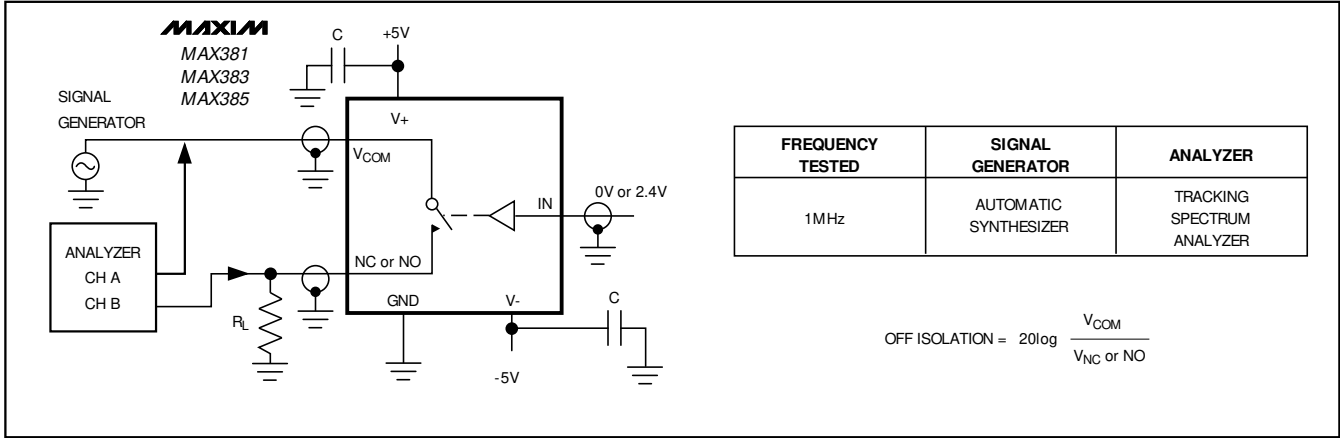

Figure 5. Off Isolation

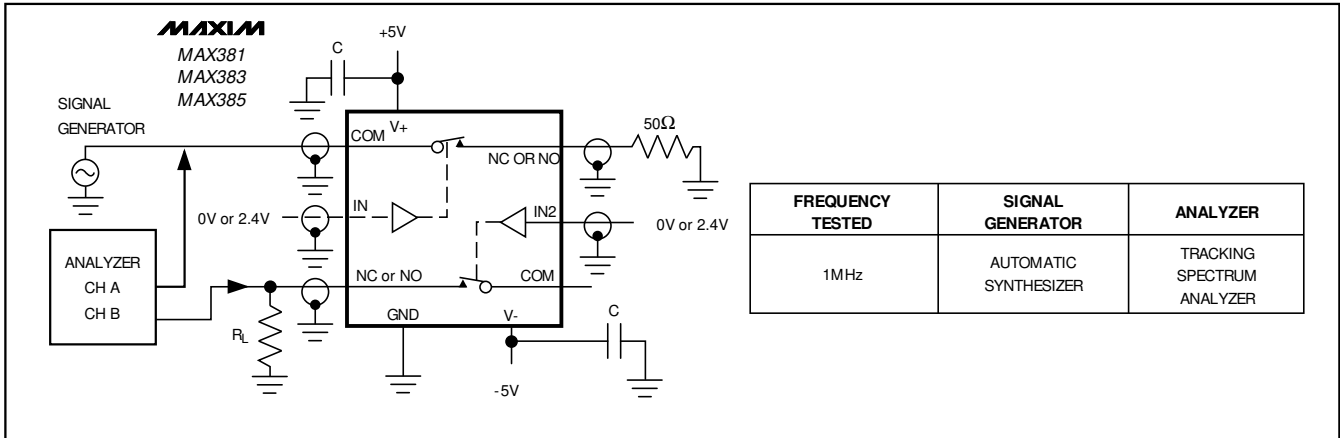

Figure 6. Crosstalk Test Circuit

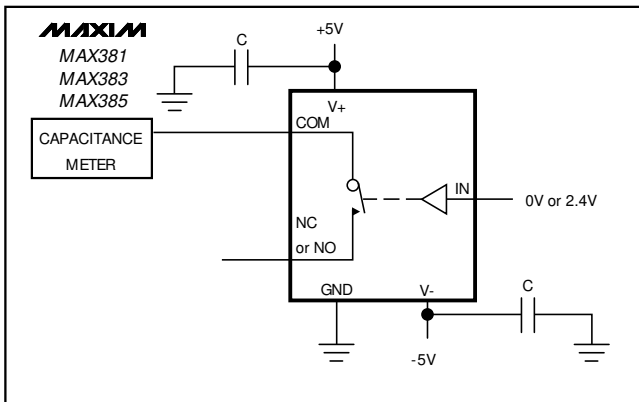

Figure 7. Channel-Off Capacitance

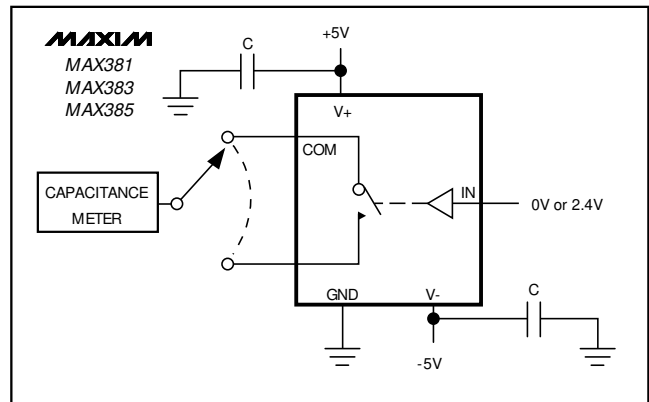

Figure 8. Channel-On Capacitance

Precision, Low-Voltage Analog Switches

Ordering Information (continued)

PART	TEMP. RANGE	PIN-PACKAGE
MAX383CPE	0°C to +70°C	16 Plastic DIP
MAX383CSE	0°C to +70°C	16 Narrow SO
MAX383C/D	0°C to +70°C	Dice*
MAX383EPE	-40°C to +85°C	16 Plastic DIP
MAX383ESE	-40°C to +85°C	16 Narrow SO
MAX383EJE	-40°C to +85°C	16 CERDIP**
MAX383MJE	-55°C to +125°C	16 CERDIP**
MAX385CPE	0°C to +70°C	16 Plastic DIP
MAX385CSE	0°C to +70°C	16 Narrow SO
MAX385C/D	0°C to +70°C	Dice*
MAX385EPE	-40°C to +85°C	16 Plastic DIP
MAX385ESE	-40°C to +85°C	16 Narrow SO
MAX385EJE	-40°C to +85°C	16 CERDIP**
MAX385MJE	-55°C to +125°C	16 CERDIP**

* Dice are tested at $T_A = +25^\circ\text{C}$ only.

** Contact factory for package availability.

Chip Topography

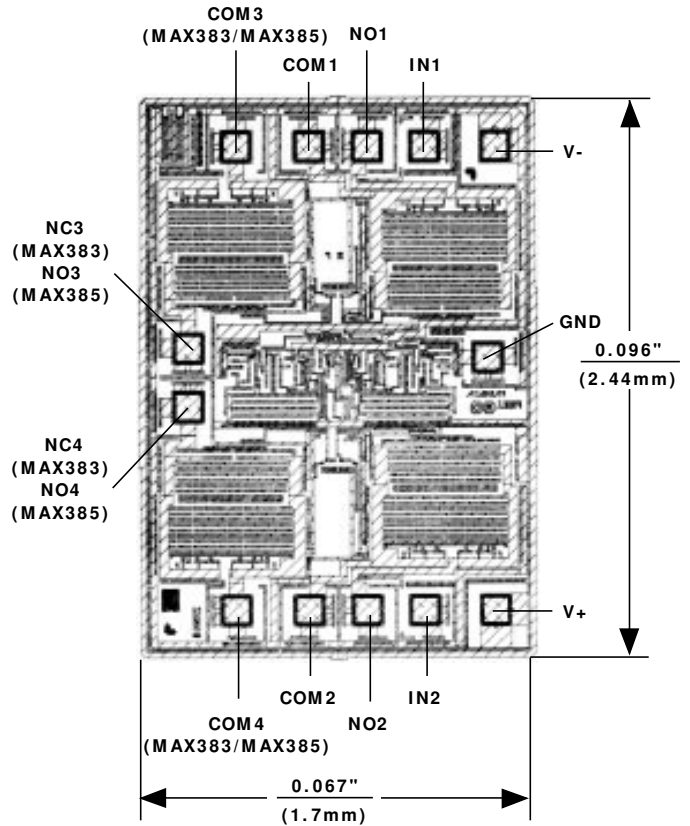

MAX381/MAX383/MAX385

TRANSISTOR COUNT: 57
SUBSTRATE CONNECTED TO V+

Precision, Low-Voltage Analog Switches

MAX381/MAX383/MAX385

Package Information

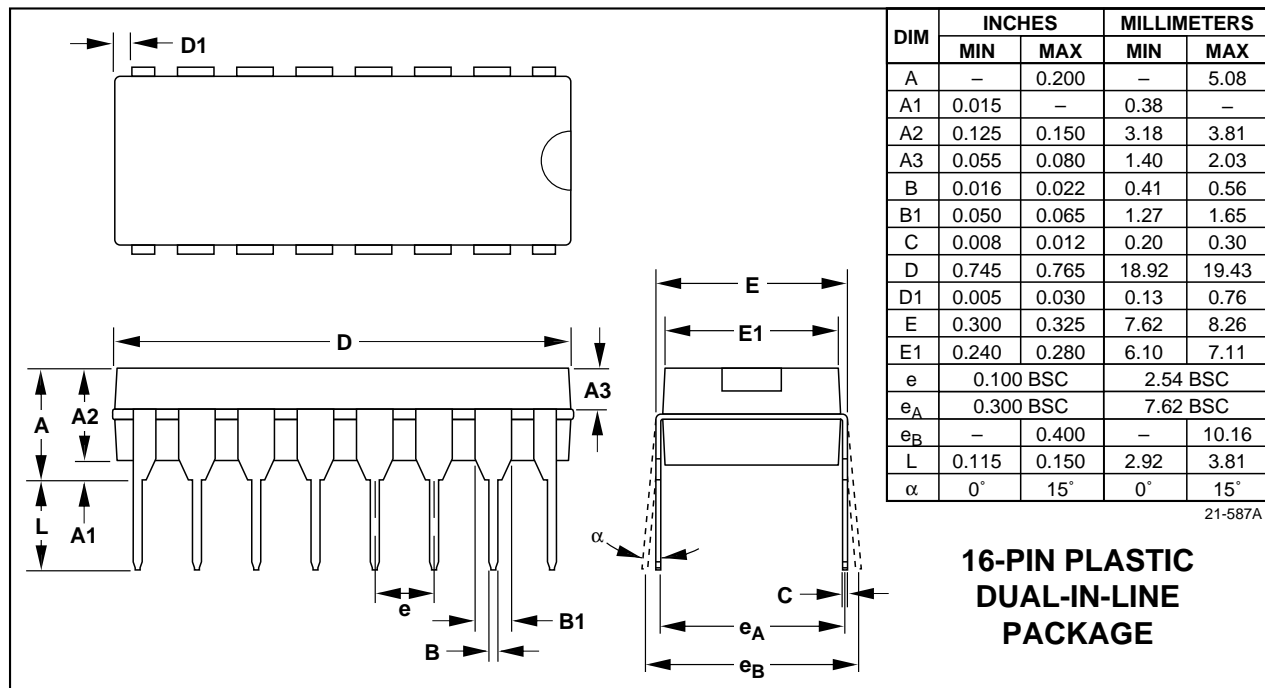
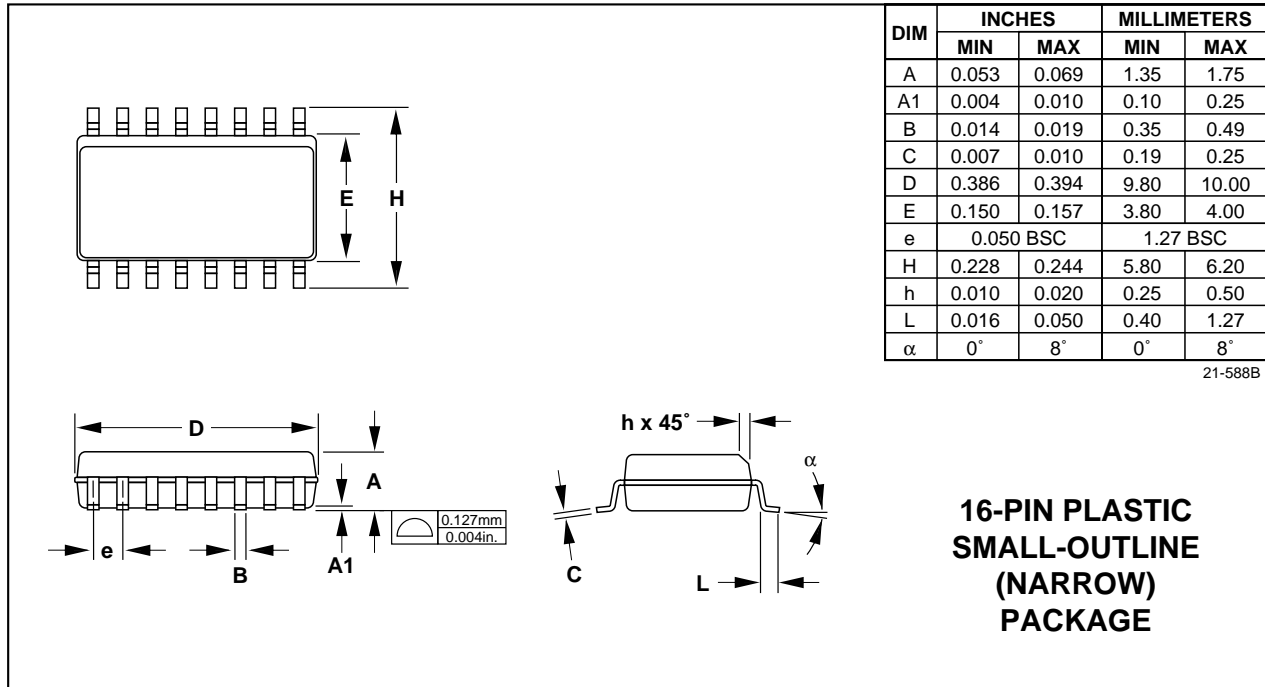

Maxim cannot assume responsibility for use of any circuitry other than circuitry entirely embodied in a Maxim product. No circuit patent licenses are implied. Maxim reserves the right to change the circuitry and specifications without notice at any time.

12 _____ Maxim Integrated Products, 120 San Gabriel Drive, Sunnyvale, CA 94086 (408) 737-7600



SITE
SEARCH
PART NO.
SEARCH

WHAT'S NEW

PRODUCTS

SOLUTIONS

DESIGN

APPNOTES

SUPPORT

BUY

COMPANY

MEMBERS

MAX381

Part Number Table

Notes:

1. See the [MAX381 QuickView Data Sheet](#) for further information on this product family or download the [MAX381 full data sheet](#) (PDF, 136kB).
2. Other options and links for purchasing parts are listed at: <http://www.maxim-ic.com/sales>.
3. [Didn't Find What You Need?](#) Ask our applications engineers. Expert assistance in finding parts, usually within one business day.
4. Part number suffixes: T or T&R = tape and reel; + = RoHS/lead-free; # = RoHS/lead-exempt. More: See [full data sheet](#) or [Part Naming Conventions](#).
5. * Some packages have variations, listed on the drawing. "PkgCode/Variation" tells which variation the product uses.

Part Number	Free Sample	Buy Direct	Package: TYPE PINS SIZE DRAWING CODE/VAR *	Temp	RoHS/Lead-Free? Materials Analysis
MAX381BEPE	<input type="checkbox"/>	<input type="checkbox"/>			RoHS/Lead-Free: No
MAX381EJE	<input type="checkbox"/>	<input type="checkbox"/>	Ceramic DIP;16 pin;.300" Dwg: 21-0045A (PDF) Use pkgcode/variation: J16-3*	-40C to +85C	RoHS/Lead-Free: No Materials Analysis
MAX381MJE	<input type="checkbox"/>	<input type="checkbox"/>	Ceramic DIP;16 pin;.300" Dwg: 21-0045A (PDF) Use pkgcode/variation: J16-3*	-55C to +125C	RoHS/Lead-Free: No Materials Analysis
MAX381C/D	<input type="checkbox"/>	<input type="checkbox"/>			RoHS/Lead-Free: No
MAX381BCPE	<input type="checkbox"/>	<input type="checkbox"/>	PDIP;16 pin;.300" Dwg: 21-0043D (PDF) Use pkgcode/variation: P16-1*	0C to +70C	RoHS/Lead-Free: No Materials Analysis
MAX381CPE	<input type="checkbox"/>	<input type="checkbox"/>	PDIP;16 pin;.300" Dwg: 21-0043D (PDF) Use pkgcode/variation: P16-1*	0C to +70C	RoHS/Lead-Free: No Materials Analysis
MAX381EPE	<input type="checkbox"/>	<input type="checkbox"/>	PDIP;16 pin;.300" Dwg: 21-0043D (PDF) Use pkgcode/variation: P16-1*	-40C to +85C	RoHS/Lead-Free: No Materials Analysis

MAX381ESE+			SOIC;16 pin;.150" Dwg: 21-0041B (PDF) Use pkgcode/variation: S16+2*	-40C to +85C	RoHS/Lead-Free: Yes Materials Analysis
MAX381ESE+T			SOIC;16 pin;.150" Dwg: 21-0041B (PDF) Use pkgcode/variation: S16+2*	-40C to +85C	RoHS/Lead-Free: Yes Materials Analysis
MAX381CSE-T				0C to +70C	RoHS/Lead-Free: No
MAX381BCSE-T				0C to +70C	RoHS/Lead-Free: No
MAX381BCSE			SOIC;16 pin;.150" Dwg: 21-0041B (PDF) Use pkgcode/variation: S16-2*	0C to +70C	RoHS/Lead-Free: No Materials Analysis
MAX381CSE			SOIC;16 pin;.150" Dwg: 21-0041B (PDF) Use pkgcode/variation: S16-2*	0C to +70C	RoHS/Lead-Free: No Materials Analysis
MAX381BESE-T				-40C to +85C	RoHS/Lead-Free: No
MAX381BESE			SOIC;16 pin;.150" Dwg: 21-0041B (PDF) Use pkgcode/variation: S16-2*	-40C to +85C	RoHS/Lead-Free: No Materials Analysis
MAX381ESE			SOIC;16 pin;.150" Dwg: 21-0041B (PDF) Use pkgcode/variation: S16-2*	-40C to +85C	RoHS/Lead-Free: No Materials Analysis
MAX381ESE-T			SOIC;16 pin;.150" Dwg: 21-0041B (PDF) Use pkgcode/variation: S16-2*	-40C to +85C	RoHS/Lead-Free: No Materials Analysis

[Didn't Find What You Need?](#)

[CONTACT US: SEND US AN EMAIL](#)