

PART NUMBER	ΑΕΔ ΧΩΛΟΡ		ΔΙΜΕΣ VAV	ΔΙΜΕΣ VAV
	ΠΟΙΤΙΟΝ 1	ΠΟΙΤΙΟΝ 2		
553-0102-300	BLANK	GREEN DIFFUSED	.097	.122±.010
553-0103-300	BLANK	YELLOW DIFFUSED	.097	.122±.010
553-0108-300	BLANK	BLUE NON-TINTED DIFFUSED	.093	.110±.010
553-0111-300	RED DIFFUSED	RED DIFFUSED	.097	.122±.010
553-0112-300	RED DIFFUSED	GREEN DIFFUSED	.097	.122±.010
553-0113-300	RED DIFFUSED	YELLOW DIFFUSED	.097	.122±.010
553-0117-300	RED DIFFUSED	ORANGE DIFFUSED	.097	.122±.010
553-0121-300	GREEN DIFFUSED	RED DIFFUSED	.097	.122±.010
553-0122-300	GREEN DIFFUSED	GREEN DIFFUSED	.097	.122±.010
553-0123-300	GREEN DIFFUSED	YELLOW DIFFUSED	.097	.122±.010
553-0127-300	GREEN DIFFUSED	ORANGE DIFFUSED	.087	.115±.010
553-0131-300	YELLOW DIFFUSED	RED DIFFUSED	.097	.122±.010
553-0132-300	YELLOW DIFFUSED	GREEN DIFFUSED	.097	.122±.010
553-0133-300	YELLOW DIFFUSED	YELLOW DIFFUSED	.097	.122±.010
553-0172-300	ORANGE DIFFUSED	GREEN DIFFUSED	.097	.122±.010
553-0177-300	ORANGE DIFFUSED	ORANGE DIFFUSED	.087	.115±.010
* 553-0188-300	BLUE NON-TINTED DIFFUSED	BLUE NON-TINTED DIFFUSED	.093	.110±.005
553-0201-300	BLANK	2 mA RED DIFFUSED	.087	.115±.010
553-0203-300	BLANK	2 mA YELLOW DIFFUSED	.087	.115±.010
553-0211-300	2 mA RED DIFFUSED	2 mA RED DIFFUSED	.087	.115±.010
553-0212-300	2 mA RED DIFFUSED	2 mA GREEN DIFFUSED	.087	.115±.010
553-0213-300	2 mA RED DIFFUSED	2 mA YELLOW DIFFUSED	.087	.115±.010
553-0221-300	2 mA GREEN DIFFUSED	2 mA RED DIFFUSED	.087	.115±.010
553-0222-300	2 mA GREEN DIFFUSED	2 mA GREEN DIFFUSED	.087	.115±.010
553-0223-300	2 mA GREEN DIFFUSED	2 mA YELLOW DIFFUSED	.087	.115±.010
553-0232-300	2 mA YELLOW DIFFUSED	2 mA GREEN DIFFUSED	.087	.115±.010
553-0233-300	2 mA YELLOW DIFFUSED	2 mA YELLOW DIFFUSED	.087	.115±.010
553-0303-300	BLANK	5 V YELLOW DIFFUSED	.087	.115±.010
553-0311-300	5 V RED DIFFUSED	5 V RED DIFFUSED	.087	.115±.010
553-0312-300	5 V RED DIFFUSED	5 V GREEN DIFFUSED	.087	.115±.010
553-0313-300	5 V RED DIFFUSED	5 V YELLOW DIFFUSED	.087	.115±.010
553-0322-300	5 V GREEN DIFFUSED	5 V GREEN DIFFUSED	.087	.115±.010
553-0323-300	5 V GREEN DIFFUSED	5 V YELLOW DIFFUSED	.087	.115±.010
553-0332-300	5 V YELLOW DIFFUSED	5 V GREEN DIFFUSED	.087	.115±.010
553-0333-300	5 V YELLOW DIFFUSED	5 V YELLOW DIFFUSED	.087	.115±.010
553-0701-300	BLANK	BI-COLOR RED/GREEN	.093	.118±.005
553-0711-300	BI-COLOR RED/GREEN	BI-COLOR RED/GREEN	.093	.118±.005
553-0714-300	BI-COLOR RED/GREEN	BI-COLOR YELLOW/GREEN	.093	.118±.005
553-0741-300	BI-COLOR YELLOW/GREEN	BI-COLOR RED/GREEN	.093	.118±.005
553-0744-300	BI-COLOR YELLOW/GREEN	BI-COLOR YELLOW/GREEN	.093	.118±.005
553-2211-300	RED TINTED NON-DIFFUSED	RED TINTED NON-DIFFUSED	.087	.115±.010
553-2222-300	GREEN TINTED NON-DIFFUSED	GREEN TINTED NON-DIFFUSED	.087	.115±.010
553-2223-300	GREEN TINTED NON-DIFFUSED	YELLOW TINTED NON-DIFFUSED	.087	.115±.010
553-2233-300	YELLOW TINTED NON-DIFFUSED	YELLOW TINTED NON-DIFFUSED	.087	.115±.010

NOTES:

- LEADS TO BE FREE OF DEFORMATION AFTER BENDING AND CUTTING.
  - LAMP MUST BE SEATED ALL THE WAY DOWN INTO HOUSING. BENDS MUST BE TIGHT & NO LONGITUDINAL TRAVEL ALONG AXIS ALLOWED.
  - PIN NUMBERS FOR REFERENCE ONLY, DESIGNATION NON-EXISTENT ON PART.
  - DIALIGHT PART NUMBER: 553-XXXX-300.
- \* ATTENTION: OBSERVE PRECAUTIONS FOR HANDLING ELECTROSTATIC SENSITIVE DEVICES.

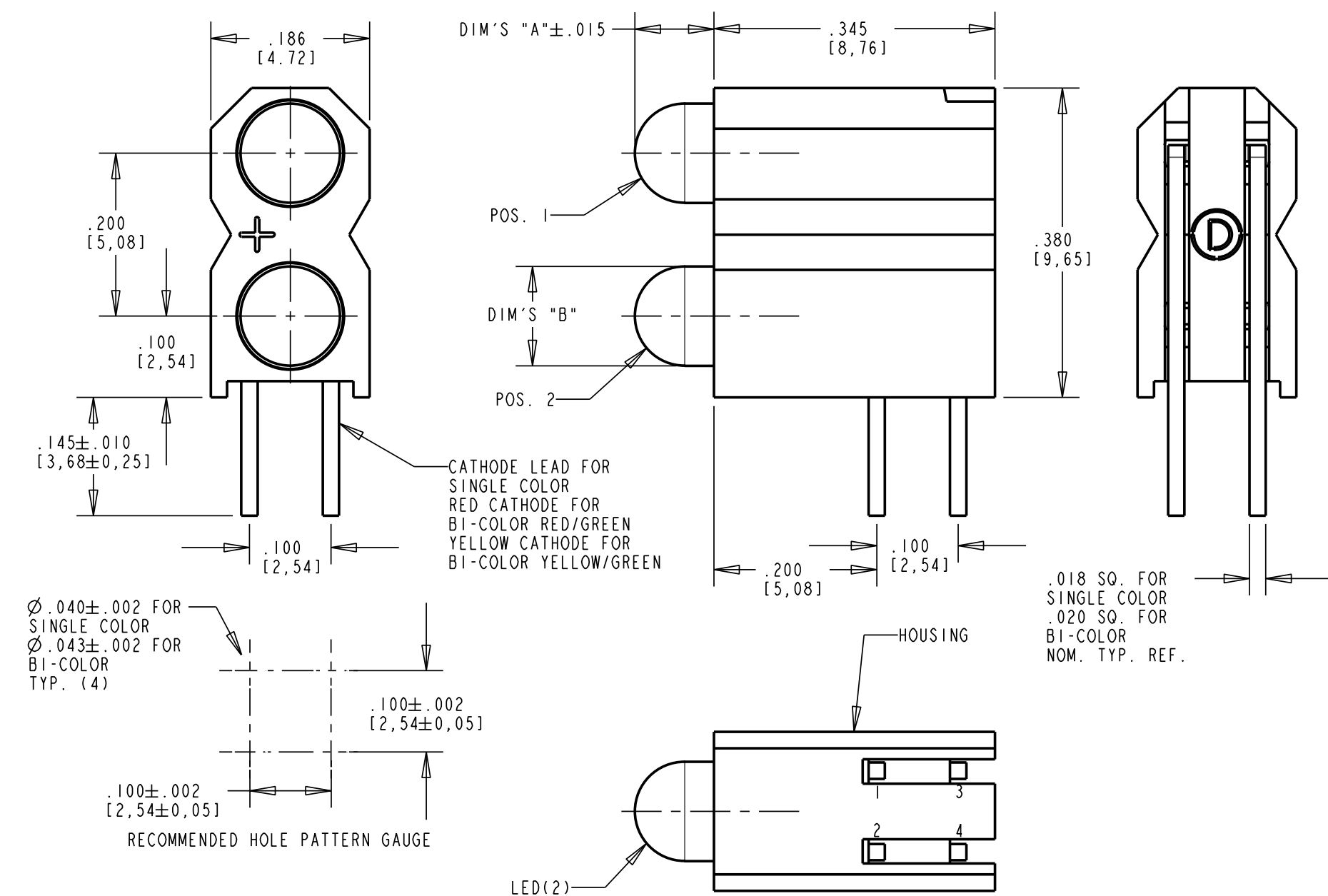
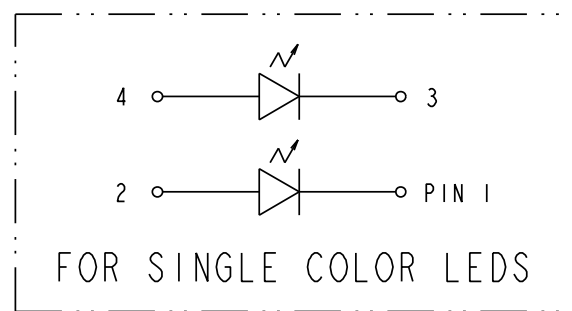
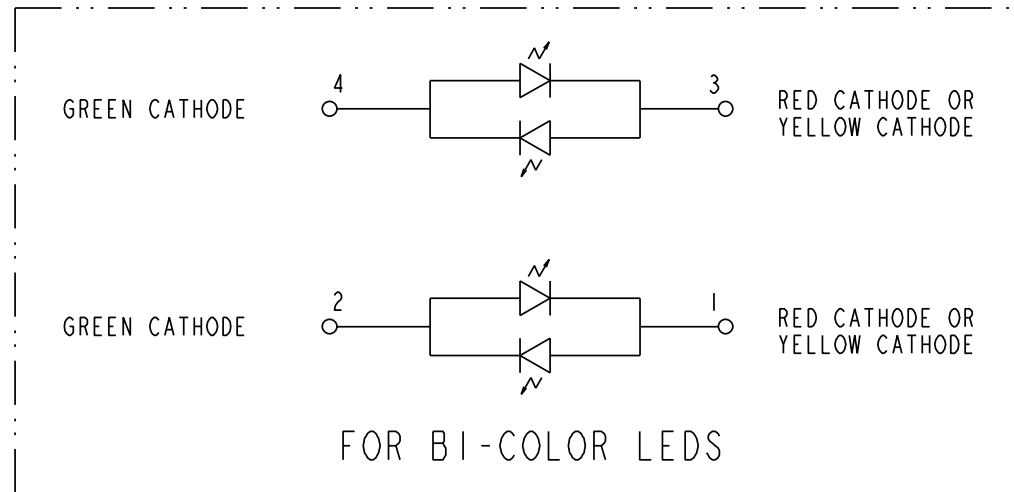

10 mA NON-DIFFUSED LED [ OPERATING CHARACTERISTICS AT 25°C ]						
CHARACTERISTICS	COLOR	MIN	TYP	MAX	UNITS	TEST CONDITIONS
LUMINOUS INTENSITY	RED	8.7	29		mcd	I <sub>f</sub> = 10 mA
	YELLOW	10	50			
	GREEN	32	50			
FORWARD VOLTAGE	RED		2.0	2.8	V	I <sub>f</sub> = 10 mA
	YELLOW		2.1	2.8		
	GREEN		2.1	2.8		
REVERSE VOLTAGE	RED	5			V	I <sub>r</sub> = 100 μA
	YELLOW	5				
	GREEN	5				
PEAK WAVELENGTH	RED		635		nm	MEASURED AT PEAK
	YELLOW		585			
	GREEN		565			

BI-COLOR LED [ OPERATING CHARACTERISTICS AT 25°C ]						
CHARACTERISTICS	COLOR	MIN	TYP	MAX	UNITS	TEST CONDITIONS
LUMINOUS INTENSITY	YELLOW GREEN	2.5	4.3		mcd	I <sub>f</sub> = 10 mA
	RED GREEN	2.5	4.7			
	RED GREEN	3.7	10.0			
FORWARD VOLTAGE	YELLOW GREEN		2.1	2.8	mA	I <sub>f</sub> = 10 mA
	RED GREEN		2.0	2.8		
	YELLOW GREEN		585			
PEAK WAVELENGTH	RED GREEN		635		nm	MEASURED AT PEAK
	RED GREEN		585			
	RED GREEN		565			

10 mA DIFFUSED LED [ OPERATING CHARACTERISTICS AT 25°C ]						
CHARACTERISTICS	COLOR	MIN	TYP	MAX	UNITS	TEST CONDITIONS
LUMINOUS INTENSITY	RED	3.6	10		mcd	I <sub>f</sub> = 10 mA
	YELLOW	2.2	6.3			
	GREEN	5.6	16			
	BLUE	6.3		20		
	ORANGE	3.4	7.0			
FORWARD VOLTAGE	RED		2.0	3.0	V	I <sub>f</sub> = 10 mA
	YELLOW		2.1	3.0		
	GREEN		2.1	3.0		
	BLUE		3.5	4.2		
	ORANGE		1.5	2.2		
REVERSE VOLTAGE	RED	3			V	I <sub>r</sub> = 10 μA
	YELLOW	3				
	GREEN	3				
	BLUE	3				
	ORANGE	5				
PEAK WAVELENGTH	RED		650		nm	MEASURED AT PEAK
	YELLOW		585			
	GREEN		563			
	BLUE		428			
	ORANGE		600			

2 mA NON-DIFFUSED LED [ OPERATING CHARACTERISTICS AT 25°C ]						
CHARACTERISTICS	COLOR	MIN	TYP	MAX	UNITS	TEST CONDITIONS
LUMINOUS INTENSITY	RED	1.0	1.6		mcd	I <sub>f</sub> = 2 mA
	YELLOW	1.0	1.6			
	GREEN	1.0	1.6			
FORWARD VOLTAGE	RED		1.7	2.2	V	I <sub>f</sub> = 2 mA
	YELLOW		1.8	2.7		
	GREEN		1.9	2.2		
REVERSE VOLTAGE	RED	5			V	I <sub>r</sub> = 50 μA
	YELLOW	5				
	GREEN	5				
PEAK WAVELENGTH	RED		635		nm	MEASURED AT PEAK
	YELLOW		585			
	GREEN		565			

5 V INTEGRAL RESISTOR LED [ OPERATING CHARACTERISTICS AT 25°C ]						
CHARACTERISTICS	COLOR	MIN	TYP	MAX	UNITS	TEST CONDITIONS
LUMINOUS INTENSITY	RED	8.7	29		mcd	V <sub>f</sub> = 5 V
	YELLOW	3.7	12.6			
	GREEN	5.6	19			
FORWARD CURRENT	RED		10	20	mA	V <sub>f</sub> = 5 V
	YELLOW		10	20		
	GREEN		10	20		
REVERSE VOLTAGE	RED	5			V	I <sub>r</sub> = 100 μA
	YELLOW	5				
	GREEN	5				
PEAK WAVELENGTH	RED		635		nm	MEASURED AT PEAK
	YELLOW		585			
	GREEN		565			

REV.	ECN NO.	REVISIONS	DRN.	CKD.	APP.	DATE
A	---	NEW RELEASE	LR		N.O.	6-12-95
B	---	ADDED P/N's -0112, -0113, -0117, -0121, -0123, -0131, -0132, -0172, -0177, -0201, -0203, -0212, -0213, -0221, -0223, -0232, -0312, -0332, -0741 & -2223; REMOVED -2203-300; ADDED NOTE 4.	TC	D.C.	N.O.	7-27-99
C	---	ADDED P/N 553-0102-300, -0188-300, -0701-300, LED SPECS. AND ATTENTION NOTE.	TC	D.C.	N.O.	10-18-99
D	---	REVISED 5V, R/G, Y/G, BI-COLOR, 10 mA NON-DIFFUSED LED SPECS.	TC	D.C.	N.O.	9-18-00
E	---	ADDED ORANGE COLOR TO 10mA DIFFUSED LED SPECS. ALSO ADDED P/N 553-0103-300 AND 553-0714-300. REVISED 2mA LOW CURRENT LED'S FORWARD VOLT. ALL TYP. SPECS.	DC	Y.C.	N.O.	2-19-01
F	---	ADDED P/N 553-0323-300	YIS	D.C.	N.O.	9-26-01
G	---	ADDED P/N 553-0313-300	DC	AM	AV	7-16-02
H	---	ADDED P/N 553-0127-300 553-0108-300	YIS			

THIS DRAWING AND THE CONTENTS HEREIN ARE CONFIDENTIAL AND THE SOLE PROPERTY OF DIALIGHT. REPRODUCTION OF THIS DRAWING OR CONSTRUCTION OF ANY PARTS WITHIN THIS DRAWING ARE FORBIDDEN WITHOUT THE WRITTEN CONSENT OF DIALIGHT.

SCALE 8:1

DRAWING NUMBER: C-15986

REV: H

TOLERANCES: UNLESS OTHERWISE SPECIFIED

FRACTIONS: ±1/64

DECIMALS (.XX): ±.02

DECIMALS (.XXX): ±.015

ANGLES: ±1°

FINISH:

FSCM 83330

TITLE: 3mm BI-LEVEL LED CBI

MATERIAL:

**Dialight** 1501 ROUTE 34 SOUTH FARMINGDALE, NJ 07727

SHEET OF FAMILY TABLES: