

Mechanical Dimensions: Inches [mm]

Tolerances ± 0.012 [0.3] Unless Otherwise Specified

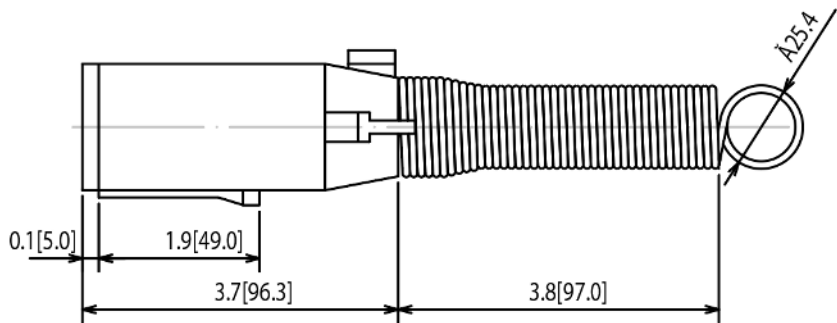
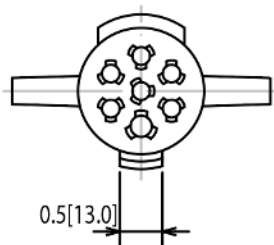
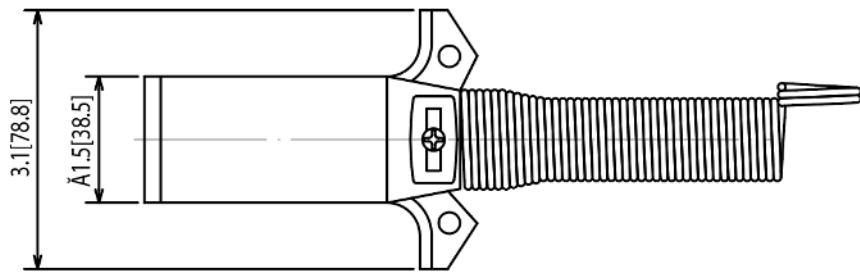

TOLERANCES:
 1mm~5mm:±0.1
 6mm~20mm:±0.2
 21mm~50mm:±0.3
 51mm~100mm:±0.5
ANGLES:±1°

Wiring Color Codes

A.T.A & S.A.E WIRING CODES RECOMMENDED STANDARD

CIRCUITS	POLE WIRING COLOR CODE	
Ground Return	White	8 GA
Clearance, Side Marker and Identification Lamps	Black	12 GA
Left Turn & Hazard Signal	Yellow	12 GA
Stop Lamps & Anti-Lock Devices	Red	10 GA
Right Turn Signal & Hazard Signal	Green	12 GA
Tail, Rear Clearance Marker, and License Plate Lamps	Brown	12 GA
Auxiliary Circuit/ABS	Blue	10 GA

Rev	Date of issue	Revision Notes	Designed	Approved
A	07-16-2019	Initial Drawing	RC	OH