

FEMALE PLUG M12 STRAIGHT TO MALE PLUG M12 90° ANGLED

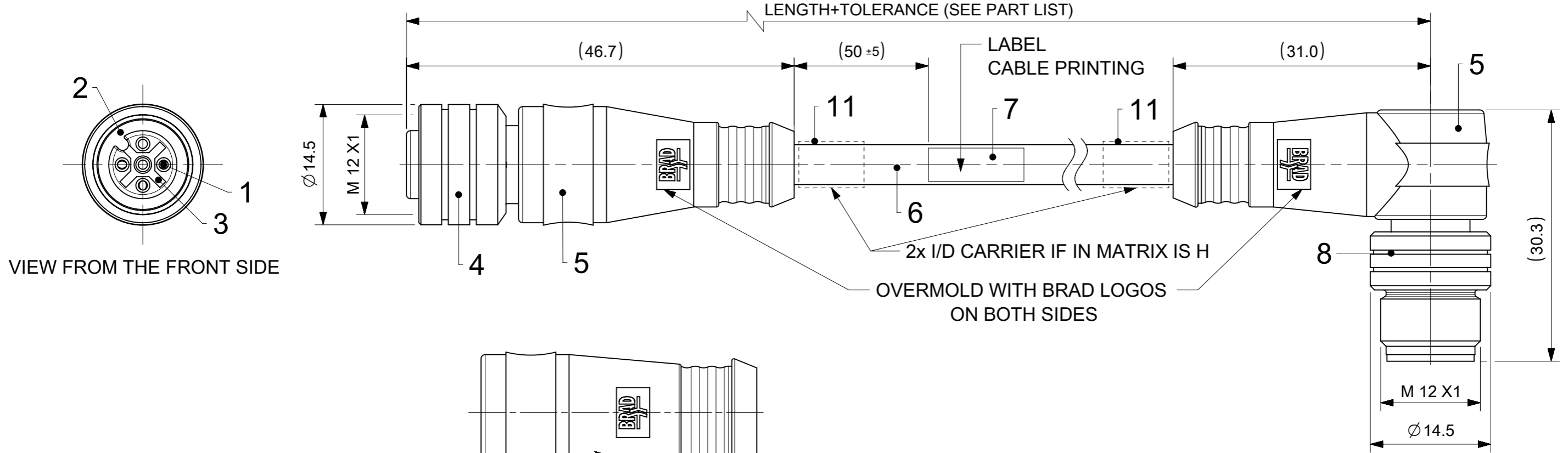

VIEW FROM THE FRONT SIDE

THICKER OVERMOLD FOR CABLES WITH O.D. BIGGER THAN 6

TECHNICAL SPECIFICATION:
 CONTACT CURRENT RATING: 3-5 POLES 4A
 8 POLES 2A
 VOLTAGE RATING: 3-4 POLES 250V
 5 POLES 60V DC
 8 POLES 30V
 PROTECTION CLASS: IP 67
 TEMPERATURE: -25°C / +85°C

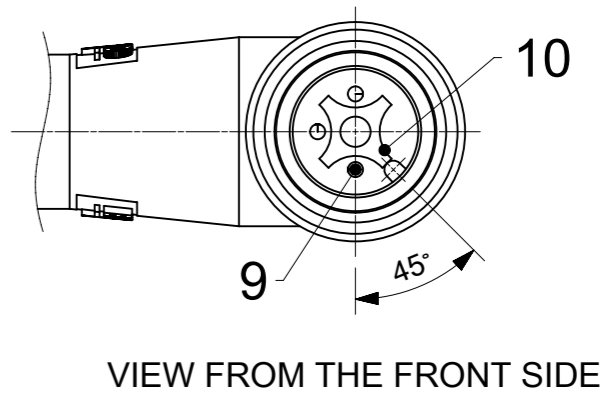

VIEW FROM THE FRONT SIDE

BILL OF MATERIAL

ITEM	QTY.	DESCRIPTION	MATERIAL	FINISH/COLOR
11	2 (SEE MATRIX)	ID CARRIER	PVC	TRANSPARENT
10	1	INSERT MALE	PUR	BLACK
9	3/4/5/8	CONTACT M12 MALE	BRASS	SELECTIVE GOLD OVER NICKEL
8	1	COUPLING NUT MALE	BRASS	NICKEL
7	1	LABEL	VINYL	YELLOW
6	-	CABLE	SEE MATRIX/ CABLE SPECIFICATION	---
5	-	OVERMOULD	TPU	SEE MATRIX
4	1	COUPLING NUT FEMALE	BRASS	NICKEL
3	1	INSERT FEMALE	PUR	BLACK
2	1	O-RING	FPM	RED
1	3/4/5/8	CONTACT M12 FEMALE	BRASS	SELECTIVE GOLD OVER NICKEL
ITEM	QTY.	DESCRIPTION	MATERIAL	FINISH/COLOR

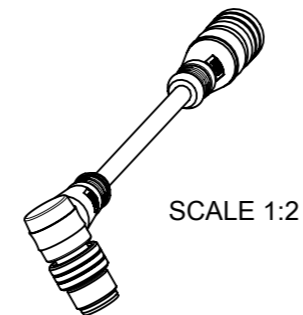

FUNCTIONAL SYMBOLS FA = 0 FE = 0 FV = 0	THIS DRAWING CONTAINS INFORMATION THAT IS PROPRIETARY TO MOLEX ELECTRONIC TECHNOLOGIES, LLC AND SHOULD NOT BE USED WITHOUT WRITTEN PERMISSION	CURRENT REV DESC: ADDED PNS 1200669890 & 1200669891		molex	
	DIMENSION UNITS: mm	SCALE: 2:1	GENERAL TOLERANCES (UNLESS SPECIFIED)		
DIVISIONAL SYMBOLS	ANGULAR TOL ± 1.0°	4 PLACES ±	EC NO: 698496	CSE M12 XP AC FE STR MA RA XM	
	3 PLACES ±	2 PLACES ± 0.05	DRWN: MDHARMANTI 2022/03/07	PRODUCT CUSTOMER DRAWING	
1 PLACE ± 0.3	0 PLACES ± 0.5	INITIAL REVISION:	APPR: RSILLER 2022/03/07	DOCUMENT NUMBER: 1200070026	
DRAFT WHERE APPLICABLE MUST REMAIN WITHIN DIMENSIONS		THIRD ANGLE PROJECTION	DRWN: DSOPPIN 2018/09/27	DOC TYPE: PSD	DOC PART: 000
		DRAWING: A3-SIZE	SERIES: 120007	REVISION: A6	SHEET NUMBER: 1 OF 4
		MATERIAL NUMBER: SEE PART LIST	CUSTOMER: GENERAL MARKET		

ENGINEERING NO. - NUMERICAL CODE (Available parts see PART LIST table. Others on request).

8 8 X 0 3 2 X X X X X X X X X X

SPECIAL TYPES

COUPLING NUT FEMALE MALE

88 = M12x1 Double ended

Poles:
3 = 3 Poles
4 = 4 Poles
5 = 5 Poles
8 = 8 Poles

Heads style:
032 = Plugs FE Straight & Male 90°

Cable types:
E02=0.25mm² PVC Black
E03=0.34mm² PVC Black
E13=0.75mm² PVC Yellow
E52=0.34mm² PVC Grey(RAL 7001)
E57=0.34mm² PVC Grey(RAL 7001)
H09=0.34mm² PUR Black
H69=0.34mm² PUR Grey LSOH SCR
I02=0.25mm² PVC Grey CEI
I03=0.34mm² PVC Grey CEI
I20=0.25mm² PVC Grey CEI SCR DC
I26=0.34mm² PVC Grey CEI SCR AC
P02=0.25mm² PUR/PVC Black
P03=0.34mm² PUR/PVC Black
P08=0.25mm² PUR Yellow HIFLEX
P20=0.34mm² PUR Grey LSOH braid
P82=0.34mm² PUR orange irradiated DC
S20=0.34mm² PVC Yellow SJTO braid

Units:
C = Centimeter
M = Meter
K = Kilometer
F = Feet

Length Examples:
020 = 2 M
060 = 6 M
100 = 10 M

Overmold color:
Blank (Standard)=Black TPU
Blank=Yellow PVC for cables
A09, S19, S20, S26
Blank=Yellow TPE-E for cables
K03, K05
A=Grey / G=Black / Y=Yellow
Coupling Nut:
Blank (Standard)=Knurled Brass Ni Plated
1=Hexagonal Stainless steel
5=Knurled Derlin
7=Knurled Brass Ni Plated, Teflon Coated
Blank=7 for cables I20, I26, K03, K05, P82, S26
9=Knurled / Hexagonal Brass Ni Plated SW13

H= 2 pcs. of I/D Carrier PVC Transparent
(Cables Ixx & P82 always with 2 pcs. of I/D Carrier even if no H in Engineering No.)

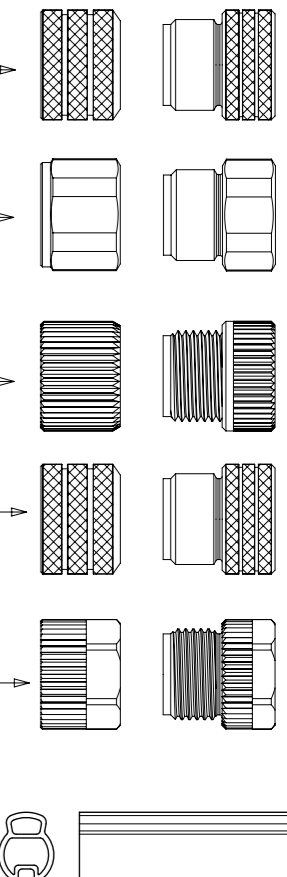

CABLE SPECIFICATION

CABLE TYPE	NO. OF WIRES	CROSS SECTION	CABLE JACKET	UL	CSA	STATIC: TEMP. / BENDING RADIUS	DYNAMIC: TEMP. / BENDING RADIUS	DRAG CHAIN	SHIELD
E02	3 / 4 / 5 / 8	0.25mm ²	PVC BLACK	UL 2464/1729	C22.2 I/II A/B 80°C/300V	-30°C to +80°C, 10xO.D.	-10°C to +80°C, 15xO.D.	-	-
E03	3 / 4 / 5	0.34mm ²	PVC BLACK	UL 2464/1729	C22.2 I/II A/B 80°C/300V	-30°C to +80°C, 10xO.D.	-10°C to +80°C, 15xO.D.	-	-
E52	4	0.34mm ²	PVC GRAY	-	-	- 30 to + 70°C	- 5 to + 70°C	-	-
H09	3 / 4 / 5	0.34mm ²	PUR BLACK LSOH	UL 21198/10493	C22.2 I/II A/B 80°C/300V	-40°C to +80°C, 5xO.D.	-25°C to +80°C, 10xO.D.	2 000 000 cycles at 20°C, Temp. range +5°C to +60°C	-
H69	4	0.2mm ²	PUR LSOH	-	-	-	-40°C to +80°C	-	-
P02	3 / 4 / 5 / 8	0.25mm ²	PUR / PVC BLACK	-	-	-30°C to +80°C, 7xO.D.	-5°C to +80°C, 15xO.D.	-	-
P03	3 / 4 / 5	0.34mm ²	PUR / PVC BLACK	-	-	-30°C to +80°C, >7xO.D.	-5°C to +80°C, >15xO.D.	-	-
P82	4	0.34mm ²	PUR IRR ORANGE	-	-	-50°C to +105°C,	-50°C to +105°C,	-	-
I03	4	0.34mm ²	PVC GRAY	-	-	-30°C to +70°C	-5°C to +70°C	-	-
K03	4	AWG18	TPE YELLOW	ITC E195601 OR PLTC	AWM I/II A/B FT4 LL54185	-	-40°C to +105°C	-	-
K05	4	0.34mm ²	TPE YELLOW	ITC E195601 OR PLTC	AWM I/II A/B FT4 LL54185	-	-40°C to +105°C	-	-
S20	4	0.34mm ²	PVC YELLOW	UL 2661/1731	C22.2 AWM II	-30°C to +105°C	-40°C to +105°C	-	-

CABLE LENGTH TOLERANCE

OVER	UPTO AND INCLUDING	TOLERANCE
0	305	+19
305	915	+45
915	1830	+56
1830	3660	+89
3660	7320	+165
7320	14640	+317
14640	30500	+610
30500	>	+2% OF LENGTH

THIS DRAWING CONTAINS INFORMATION THAT IS PROPRIETARY TO MOLEX ELECTRONIC TECHNOLOGIES, LLC AND SHOULD NOT BE USED WITHOUT WRITTEN PERMISSION

FUNCTIONAL SYMBOLS: $\nabla/A = 0$, $\nabla/E = 0$, $\nabla/P = 0$

DIMENSION UNITS: mm, SCALE: 1:1

GENERAL TOLERANCES (UNLESS SPECIFIED): ANGULAR TOL ± 1.0°, 4 PLACES ±, 3 PLACES ±, 2 PLACES ± 0.05, 1 PLACE ± 0.3, 0 PLACES ± 0.5

DRAFT WHERE APPLICABLE MUST REMAIN WITHIN DIMENSIONS

THIRD ANGLE PROJECTION

DRAWING: A3-SIZE, SERIES: 120007

CURRENT REV DESC: ADDED PNS 1200669890 & 1200669891

EC NO: 698496
DRWN: MDHARMANTI 2022/03/07
CHK'D: RSILLER 2022/03/07
APPR: RSILLER 2022/03/07

INITIAL REVISION:
DRWN: DSOPPIN 2018/09/27
APPR: RSILLER 2018/10/22

DOCUMENT NUMBER: 1200070026, DOC TYPE: PSD, DOC PART: 000, REVISION: A6

MATERIAL NUMBER: SEE PART LIST, CUSTOMER: GENERAL MARKET, SHEET NUMBER: 2 OF 4

molex
CSE M12 XP AC FE STR MA RA XM
PRODUCT CUSTOMER DRAWING

CONTACT POSITION FRONT VIEW:

3 POLES FEMALE		3 POLES MALE		4 POLES FEMALE		4 POLES MALE		5 POLES FEMALE		5 POLES MALE		8 POLES FEMALE		8 POLES MALE			
PIN	WIRE	PIN	WIRE	PIN	WIRE	PIN	WIRE	PIN	WIRE	PIN	WIRE	PIN	WIRE	PIN	WIRE	PIN	WIRE
1	BROWN	1	BROWN	1	BROWN	1	BROWN	1	BROWN	1	BROWN	1	BROWN	1	WHITE	1	WHITE
2	-	2	-	2	WHITE	2	WHITE	2	WHITE	2	WHITE	2	WHITE	2	BROWN	2	BROWN
3	BLUE	3	BLUE	3	BLUE	3	BLUE	3	BLUE	3	BLUE	3	BLUE	3	GREEN	3	GREEN
4	BLACK	4	BLACK	4	BLACK	4	BLACK	4	BLACK	4	BLACK	4	BLACK	4	YELLOW	4	YELLOW
5	-	5	-	5	-	5	-	5	-	5	GREY OR GREEN/YELLOW	5	GREY OR GREEN/YELLOW	5	GREY	5	GREY
CODING REQUIRED TO IEC 61076-2-101				CODING REQUIRED TO IEC 61076-2-101				CODING REQUIRED TO IEC 61076-2-101				6	PINK	6	PINK		
												7	BLUE	7	BLUE		
												8	RED	8	RED		
												CODING REQUIRED TO IEC 61076-2-101					

FUNCTIONAL SYMBOLS FA = 0 FE = 0 FE = 0	THIS DRAWING CONTAINS INFORMATION THAT IS PROPRIETARY TO MOLEX ELECTRONIC TECHNOLOGIES, LLC AND SHOULD NOT BE USED WITHOUT WRITTEN PERMISSION		molex	
	DIMENSION UNITS	SCALE		
	mm	1:1	PRODUCT CUSTOMER DRAWING	
	GENERAL TOLERANCES (UNLESS SPECIFIED)		DOCUMENT NUMBER	
ANGULAR TOL ± 1.0°		1200070026		
4 PLACES ±		DOC TYPE		
3 PLACES ±		PSD		
2 PLACES ± 0.05		DOC PART		
1 PLACE ± 0.3		000		
0 PLACES ± 0.5		REVISION		
DRAFT WHERE APPLICABLE MUST REMAIN WITHIN DIMENSIONS		A6		
THIRD ANGLE PROJECTION		SHEET NUMBER		
DRAWING		3 OF 4		
A3-SIZE		MATERIAL NUMBER		
120007		SEE PART LIST		
SERIES		CUSTOMER		
GENERAL MARKET				

PART LIST

NO.	MOLEX PN	ENGINEERING PN	LENGTH (mm)
1	1200070158	883032E03M003	300
2	1200070159	883032E03M006	600
3	1200070160	883032E03M010	1000
4	1200070161	883032E03M020	2000
5	1200668205	883032E03M050	5000
6	1200072378	883032E03M060	6000
7	1200668053	883032E03M100	10000
8	1200668268	883032E03M200	20000
9	1200072879	883032H09M010	1000
10	1200070166	883032I03M006	600
11	1200668007	883032I03M010	1000
12	1200070171	883032P03M006	600
13	1200070172	883032P03M010	1000
14	1200070173	883032P03M020	2000
15	1200070174	883032P03M030	3000
16	1200072294	883032P03M0305	3000
17	1200668341	883032P03M050	5000
18	1200668763	883032P03M0501	5000
19	1200072705	883032P03M060	6000
20	1200070184	883032S20M010	1000
21	1200070185	883032S20M020	2000
22	1200668663	884032E02M050	5000
23	1200668072	884032E03M006	600
24	1200668073	884032E03M010	1000
25	1200668755	884032E03M012	1200
26	1200668756	884032E03M014	1400
27	1200665032	884032E03M020	2000
28	1200071014	884032E03M030	3000
29	1200668074	884032E03M050	5000
30	1200072163	884032E03M0501	5000
31	1200668075	884032E03M100	10000
32	1200668200	884032E03M1001	10000
33	1200668307	884032E03M1005	10000
34	1200668309	884032E03M1205	12000
35	1200668173	884032E03M1501	15000
36	1200668223	884032E03M200	20000
37	1200668308	884032E03M2005	20000
38	1200071277	884032E52M010A	1000
39	1200070841	884032E52M020A	2000
40	1200668494	884032H09M010	1000
41	1200668290	884032H09M020	2000
42	1200668311	884032H69M010	1000
43	1200668076	884032H69M030	3000
44	1200668312	884032H69M050	5000
45	1200665040	884032H69M100	10000
46	1200072424	884032I03M003	300
47	1200668522	884032I03M020	2000
48	1200661012	884032K03M006	600
49	1200661013	884032K03M010	1000
50	1200661014	884032K03M020	2000
51	1200661015	884032K03M030	3000
52	1200661598	884032K03M036	3600

NO.	MOLEX PN	ENGINEERING PN	LENGTH (mm)
53	1200661017	884032K03M050	5000
54	1200661018	884032K03M060	6000
55	1200661021	884032K03M090	9000
56	1200661022	884032K03M100	10000
57	1200661023	884032K03M120	12000
58	1200661480	884032K03M200	20000
59	1200660398	884032K05M005	500
60	1200660400	884032K05M010	1000
61	1200660401	884032K05M015	1500
62	1200660402	884032K05M020	2000
63	1200660403	884032K05M030	3000
64	1200073045	884032K05M035	3500
65	1200660404	884032K05M040	4000
66	1200660405	884032K05M050	5000
67	1200660406	884032K05M060	6000
68	1200073042	884032K05M070	7000
69	1200661540	884032K05M080	8000
70	1200668345	884032P03M002G	200
71	1200072838	884032P03M003	300
72	1200071519	884032P03M006	600
73	1200071407	884032P03M010	1000
74	1200070547	884032P03M0105	1000
75	1200669261	884032P03M015	1500
76	1200070026	884032P03M020	2000
77	1200071520	884032P03M030	3000
78	1200070914	884032P03M050	5000
79	1200072213	884032P03M1005	10000
80	1200668077	884032P82M0037	300
81	1200668343	884032P82M0067	600
82	1200668267	884032P82M0107	1000
83	1200668282	884032P82M0157	1500
84	1200668078	884032P82M0207	2000
85	1200668177	884032S20M020	2000
86	1200668161	884032S20M030	3000
87	1200070907	884032S20M050	5000
88	1200668974	885032E03M003	300
89	1200668979	885032E03M006	600
90	1200071271	885032E03M010	1000
91	1200668092	885032E03M020	2000
92	1200668975	885032E03M025	2500
93	1200668976	885032E03M030	3000
94	1200668977	885032E03M050	5000
95	1200668978	885032E03M100	10000
96	1200668493	885032H09M010	1000
97	1200668603	885032P03M020G	2000
98	1200661925	885032P03M080	8000
99	1200661926	885032P03M100	10000
100	1200669119	885032P03M190	19000
101	1200669767	888032E02M0201	2000
102	1200669768	888032E02M0301	3000
103	1200669769	888032E02M0501	5000

NO.	MOLEX PN	ENGINEERING PN	LENGTH (mm)
104	1200669770	888032E02M1001	10000
105	1200669892	884032E03M009	900
106	1200669893	884032E03M013	1300
107	1200669894	884032E03M016	1600
108	1200669895	884032E03M021	2100
109	1200669896	884032E03M032	3200
110	1200669897	884032E03M040	4000
111	1200669890	884032P03M060	6000
112	1200669891	884032P03M100	10000
113			
114			
115			
116			
117			
118			
119			
120			
121			
122			
123			
124			
125			
126			
127			
128			
129			
130			
131			
132			
133			
134			
135			
136			
137			
138			
139			
140			

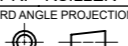
FUNCTIONAL SYMBOLS	THIS DRAWING CONTAINS INFORMATION THAT IS PROPRIETARY TO MOLEX ELECTRONIC TECHNOLOGIES, LLC AND SHOULD NOT BE USED WITHOUT WRITTEN PERMISSION		
	DIMENSION UNITS	SCALE	CURRENT REV DESC: ADDED PNs 1200669890 & 1200669891
$\nabla_A = 0$	mm	1:1	 CSE M12 XP AC FE STR MA RA XM PRODUCT CUSTOMER DRAWING
$\nabla_E = 0$	GENERAL TOLERANCES (UNLESS SPECIFIED)		
$\nabla_F = 0$	ANGULAR TOL ± 1.0°		
DIVISIONAL SYMBOLS	4 PLACES	±	
	3 PLACES	±	EC NO: 698496
	2 PLACES	± 0.05	DRWN: MDHARMANTI 2022/03/07
	1 PLACE	± 0.3	CHK'D: RSILLER 2022/03/07
	0 PLACES	± 0.5	APPR: RSILLER 2022/03/07
DRAFT WHERE APPLICABLE MUST REMAIN WITHIN DIMENSIONS		THIRD ANGLE PROJECTION	INITIAL REVISION:
			DRWN: DSOPPIN 2018/09/27
		DRAWING	APPR: RSILLER 2018/10/22
		SERIES	DOCUMENT NUMBER
		A3-SIZE	1200070026
		120007	DOC TYPE
		SEE PART LIST	PSD
		CUSTOMER	DOC PART
		GENERAL MARKET	000
		SHEET NUMBER	REVISION
		4 OF 4	A6