

EasyMx PRO™ v7 for Tiva™ C Series

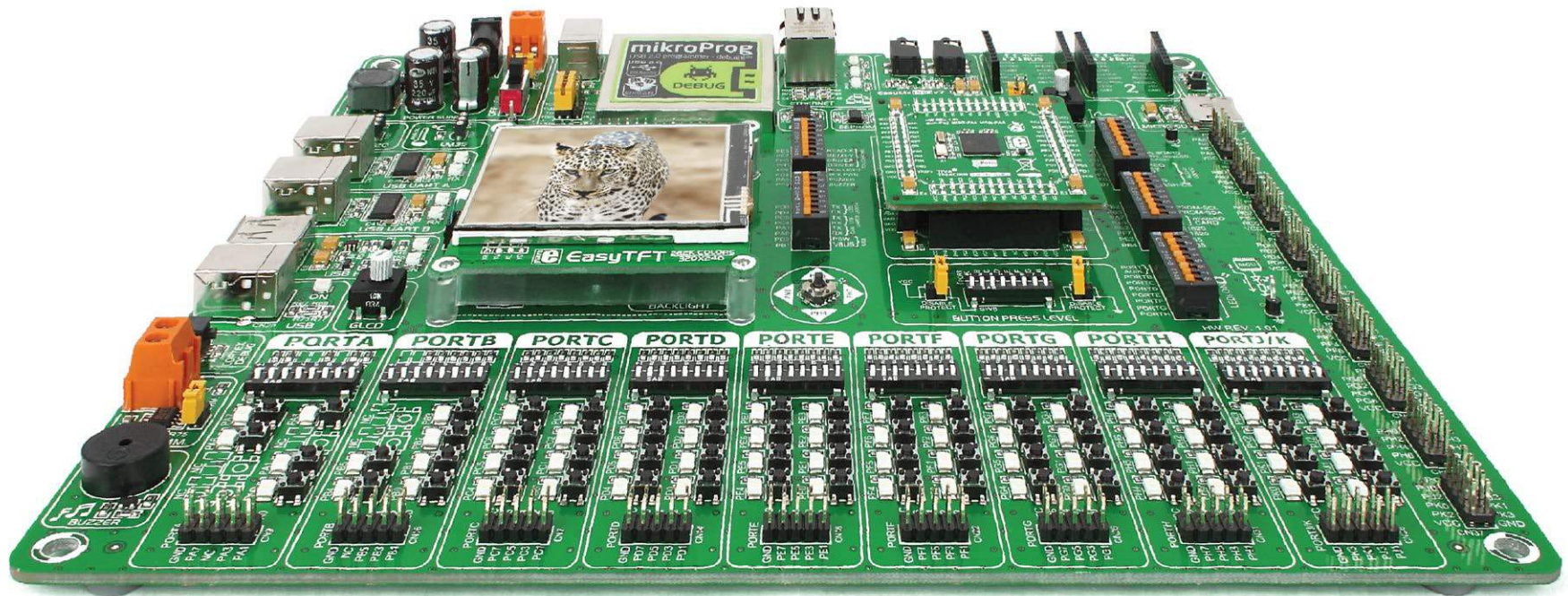

55

microcontrollers supported
The ultimate Tiva™ board



Many on-board modules
Multimedia peripherals



Easy-add extra boards
mikroBUS™ sockets

connectivity



Two connectors for each port
Amazing Connectivity



Fast USB 2.0 programmer and
In-Circuit Debugger

To our valued customers

From day one, we in MikroElektronika set ourselves the highest possible goals in pursuit of excellence. That same day, the idea for Easy development boards was born. In its each and tiniest piece we had put all our energy, creativity, and sense of what's best for an engineer.

We present you with the 7th generation of our boards, which bring us some exciting new features. We hope that you like it as much as we do.

Use it wisely and have fun.



Nebojsa Matic,
Owner and General Manager
of MikroElektronika

Table of contents

Introduction

Introduction	04
It's good to know	05

Power Supply

Power supply	06
--------------------	----

Supported MCUs

Default MCU card	08
Other supported MCU cards	11

Programmer/debugger

On-board programmer	12
List of MCUs supported with mikroProg™	13
Installing programmer drivers	14
Programming software	15
Hardware Debugger	16

Connectivity

Input/Output group	18
mikroBUS™ sockets	20
click™ boards	21

Communication

USB-UART A	22
USB-UART B	23
USB Host communication	24
USB Device communication	25
Ethernet communication	26
CAN communication	27

Multimedia

Audio Input/Output	28
microSD card slot	29
TFT display 320x240px	30
Touch panel controller	31
GLCD 128x64	32
Navigation switch	33

Other Modules

DS1820 - Digital temperature sensor	34
LM35 - Analog temperature sensor	35
Serial flash	36
I ² C EEPROM	37
ADC inputs	38
Piezo buzzer	39
Additional GNDs	40

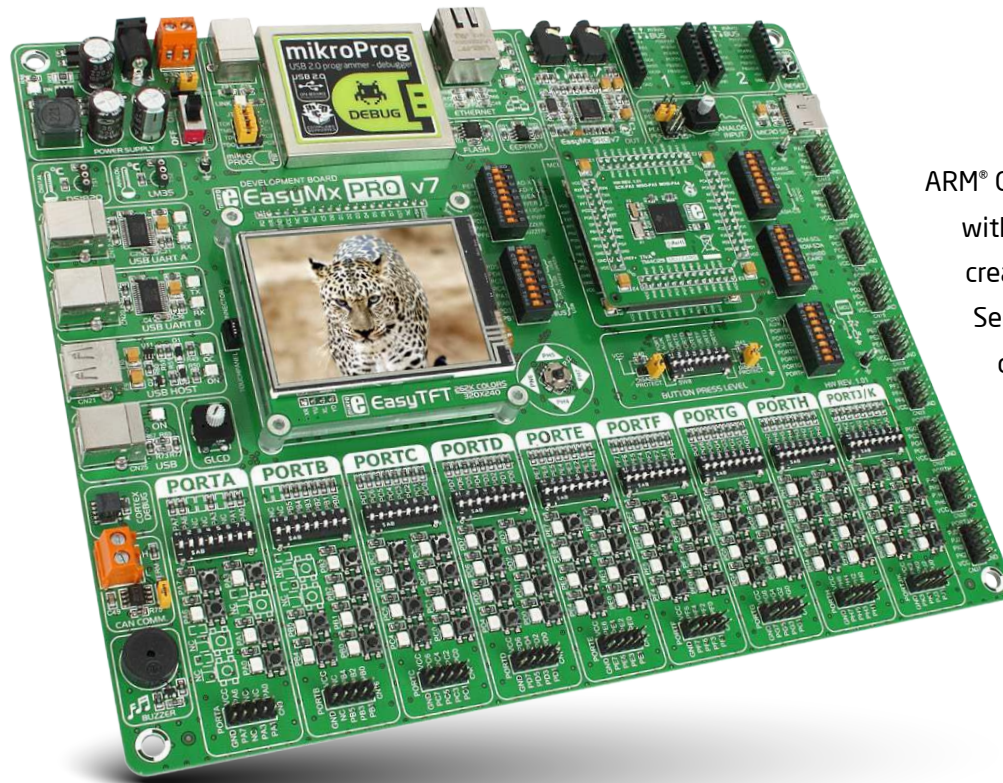

Introduction

ARM® Cortex™-M4 are increasingly popular microcontrollers. They are rich with modules, with high performance and low power consumption, so creating a development board the size of EasyMx PRO™ v7 for Tiva™ C Series was really a challenge. We wanted to put as many peripherals on the board as possible, to cover many internal modules. We have gone through a process of fine tuning the board's performance, and used 4-layer PCB to achieve maximum efficiency. Finally, it had met all of our expectations, and even exceeded some. We present you the board which is powerful, well organized, with on-board programmer and debugger and is ready to be your strong ally in development.

EasyMx PRO™ v7 development Team

Two connectors for each port Amazing connectivity

EasyMx PRO™ v7 for Tiva™ C Series is all about connectivity. Having two different connectors for each port, you can connect accessory boards, sensors and your custom electronics easier than ever before.



Everything is already here mikroProg™ on board

Powerful on-board mikroProg™ programmer and hardware debugger can program and debug over 55 Tiva™ C Series microcontrollers. You will need it, whether you are a professional or a beginner.

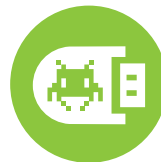

Ready for all kinds of development Multimedia peripherals

TFT 320x240 with touch panel, stereo mp3 codec, audio input and output, navigation switch and microSD card slot make a perfect set of peripherals for multimedia development.



For easier connections mikroBUS™ support

Just plug in your click™ board, and it's ready to work. We picked up a set of the most useful pins you need for development and made a pinout standard you will enjoy using.



It's good to know

TM4C129XNCZAD is the default microcontroller

TM4C129XNCZAD is the default chip of EasyMx PRO™ v7 for Tiva C Series. It belongs to ARM® Cortex™-M4 family. It operates at **120MHz**, has **1024 KB** of Flash memory, **256 KB** of single-cycle System SRAM, integrated Ethernet controller with PHY, **USB 2.0** (OTG, Host, Device), 140 General purpose **I/O pins**, 7x16/32-bit **timers**, 2x12-bit **A/D** (24 channels), a 12-bit **D/A**, 8x**UARTs**, internal Real time clock (**RTC**), 10x**I2C**, 4x**SPI** and 2x**CAN** controllers. It has Serial wire debug (SWD) and JTAG interfaces for programming and debugging.

- Great choice for both beginners and professionals
- Rich with modules
- Comes with examples for mikroC, mikroBasic and mikroPascal compilers

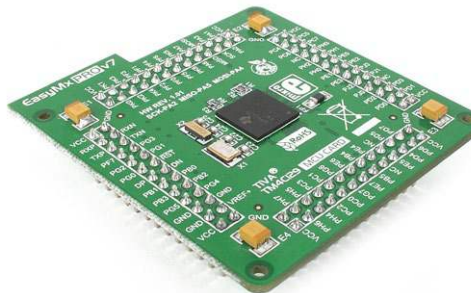

System specification



power supply
7-23V AC or 9-32V DC
or via USB cable (5V DC)



power consumption
~76mA when all peripheral modules are disconnected



board dimensions
266 x 220mm (10.47 x 8.66 inch)



weight
~500g (1.1 lbs)

Package contains



1 Damage resistant protective box

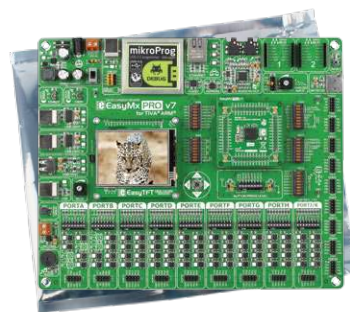

2 EasyMx PRO™ v7 for Tiva™ C Series board in antistatic bag



3 USB cable



4 User Manuals and Board schematics

Power supply

Board contains a switching power supply that creates stable voltage and current levels necessary for powering each part of the board. The power supply section contains a specialized **MC34063A** power regulator which creates a VCC-3.3V power supply, thus making the board capable of supporting 3.3V microcontrollers. Power supply unit can be powered in three different ways: with **USB power supply (CN6)**, using external adapters via adapter connector (**CN34**) or additional screw terminals (**CN35**). External adapter voltage levels must be in range of **9-32V DC and 7-23V AC**. Use jumper **J1** to specify which power source you are using. Upon providing the power using either external adapters or a USB power source you can turn on the power supply by using **SWITCH 1 (Figure 3-1)**. Power LED **ON (Green)** will indicate the presence of power supply.

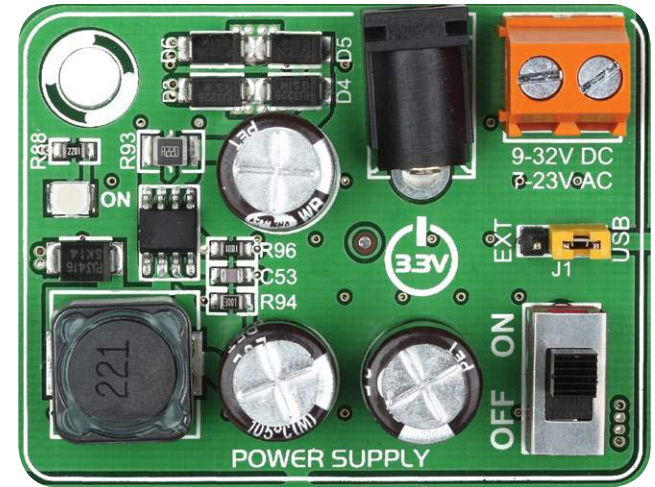
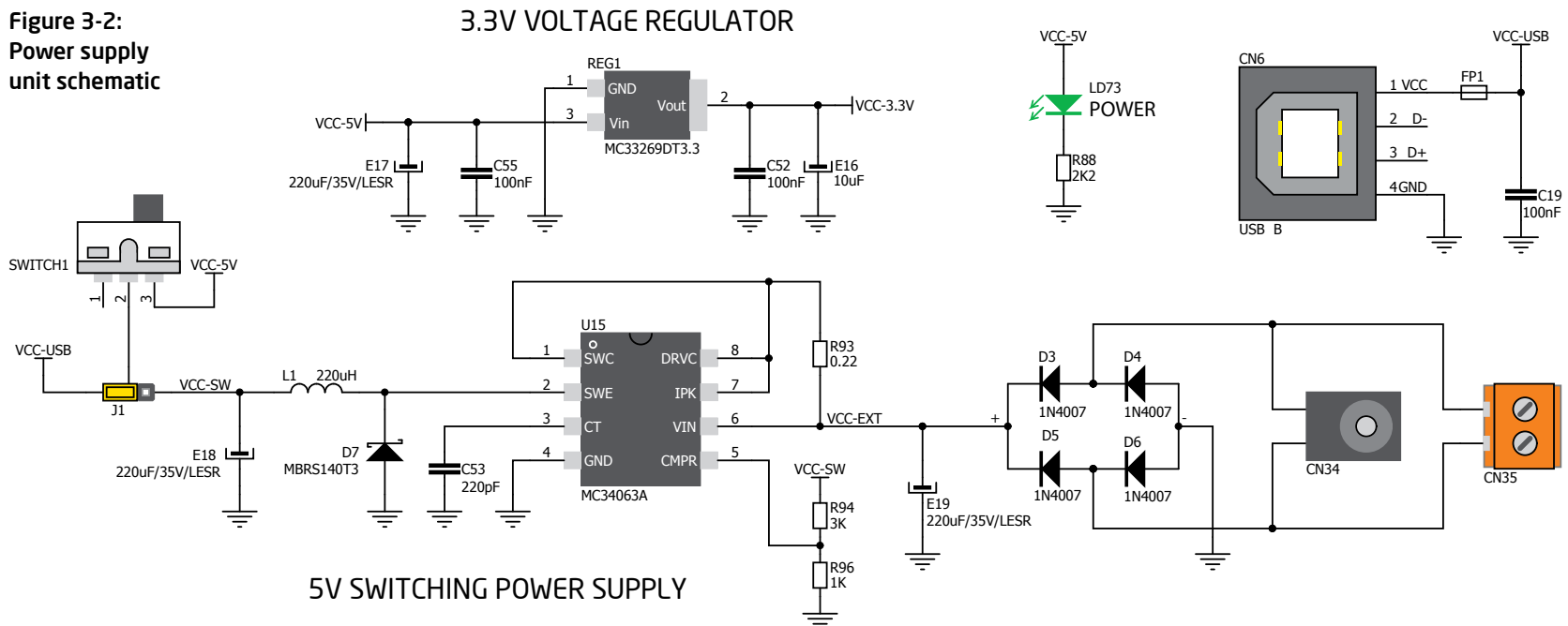

Figure 3-1: Power supply unit of EasyMx PRO™ v7 for Tiva™ C Series

Figure 3-2: Power supply unit schematic





The board's power supply unit creates a stable 3.3V voltage necessary for the operation of the microcontroller and all on-board modules.

Power supply:

via DC connector or screw terminals (7V to 23V AC or 9V to 32V DC), or via USB cable (5V DC)

Power capacity:

up to 500mA with USB, and up to 600mA with external power supply

How to power the board?

1. With USB cable



Set J1 jumper to USB position

To power the board with a USB cable, place jumper **J1** in USB position. You can then plug in the USB cable as shown on images **1** and **2**, and turn the power switch ON.

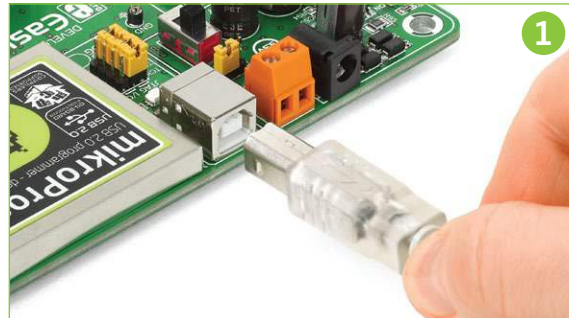

2. With adapter



Set J1 jumper to EXT position

To power the board with an adapter connector, place jumper **J1** in EXT position. You can then plug in the adapter cable as shown on images **3** and **4**, and turn the power switch ON.

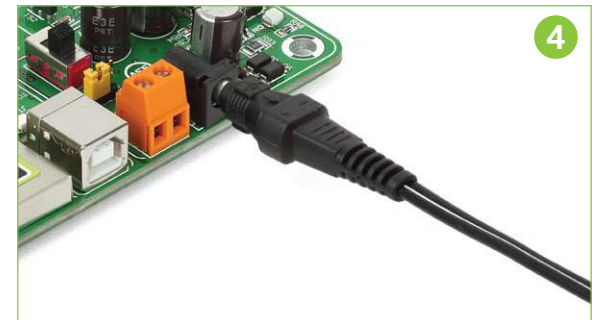

3. With laboratory power supply



Set J1 jumper to EXT position

To power the board using screw terminals, place jumper **J1** in EXT position. You can then screw-on the cables in the screw terminals as shown on images **5** and **6**, and turn the power switch ON.

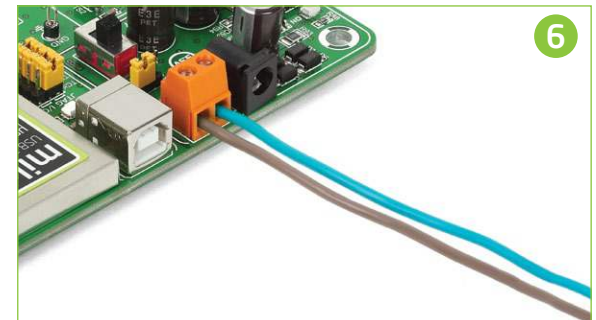
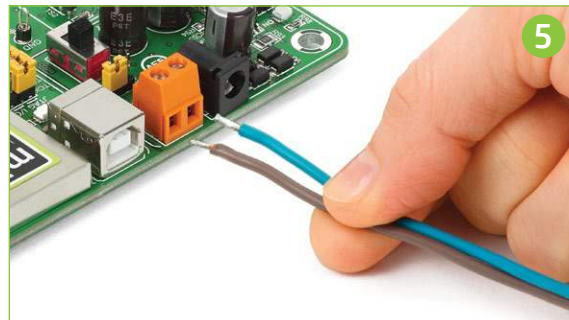

Default MCU card

Microcontrollers are supported using specialized 104-pin MCU cards that can be inserted into the on-board MCU socket. There are several types of cards which cover all microcontroller families of Tiva™ C Series Cortex™-M4. The **Default MCU card** that comes with the EasyMx PRO™ v7 for Tiva™ C Series package is shown on **Figure 4-1**. It contains the **TM4C129XNCZAD** microcontroller with on-chip peripherals and is a great choice for both beginners and professionals. After testing and building the final program, this card can also be taken out of the board socket and used in your final device.

- 1 **TM4C129XNCZAD** is the default chip of EasyMx PRO™ v7 for Tiva™ C Series. It belongs to ARM® Cortex™-M4F family. It operates at **120MHz**, has **1024 KB** of Flash memory, **256 KB** of single-cycle System SRAM, integrated Ethernet controller with PHY, **USB 2.0** (OTG, Host, Device), 140 General purpose **I/O pins**, 7x16/32-bit **timers**, 2x12-bit **A/D** (24 channels), a 12-bit **D/A**, 8x**UARTs**, internal Real time clock (**RTC**), 10x**I2C**, 4x**SPI** and 2x**CAN** controllers. It has Serial wire debug (SWD) and JTAG interfaces for programming and debugging.
- 2 **25MHz crystal oscillator**. We carefully chose the most convenient crystal value that provides clock frequency which can be used directly, or with the PLL multipliers to create higher MCU clock value. MCU card also contains 32.768 kHz crystal oscillator which provides external clock for RTCC module.
- 3 **32.768-kHz external crystal oscillator** which provides external clock for the internal hibernation module.

Figure 4-1: Default MCU card with TM4C129XNCZAD

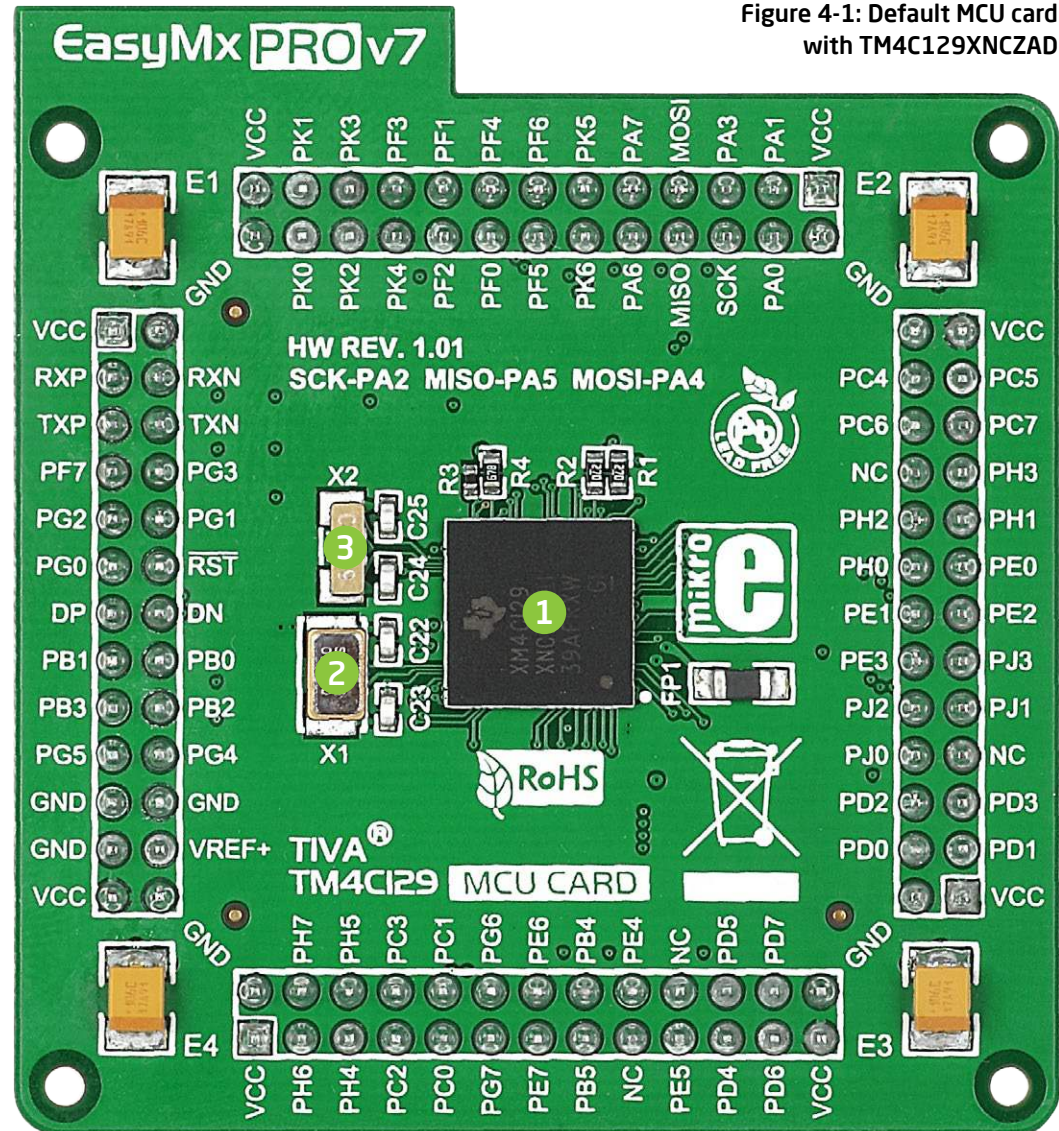

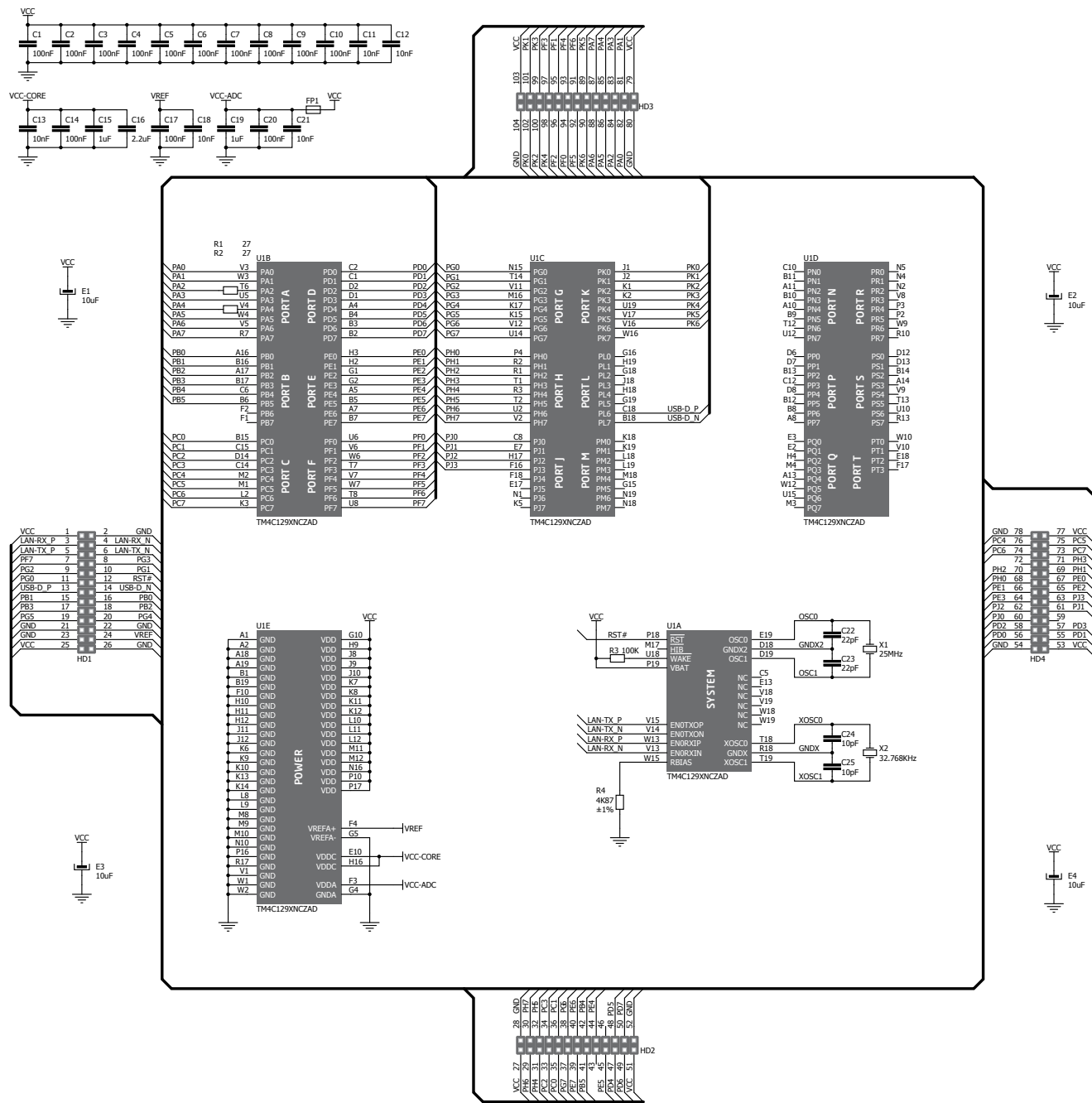

Figure 4-2: Default MCU card and boot configuration schematic

How to properly insert your MCU card into the socket?

Before you plug the microcontroller card into the socket, make sure that the **power supply is turned off**. Images below show how to correctly plug in the card. First make sure that the MCU card orientation matches the silkscreen outline

on the EasyMx PRO™ v7 Tiva™ C Series board MCU socket. Hold the MCU card over the socket, so each header is properly aligned with the socket, as shown in **Figure 4-4**. Then put the MCU card slowly down until all the pins slide into the socket.

Check again if everything is placed correctly and press the MCU card until it is completely plugged into the socket as shown in **Figure 4-5**. If done correctly all pins should be fully inserted. Only now you can turn on the power supply.

1

Figure 4-3: On-board MCU socket has silkscreen markings which will help you to correctly orient the MCU card before inserting.

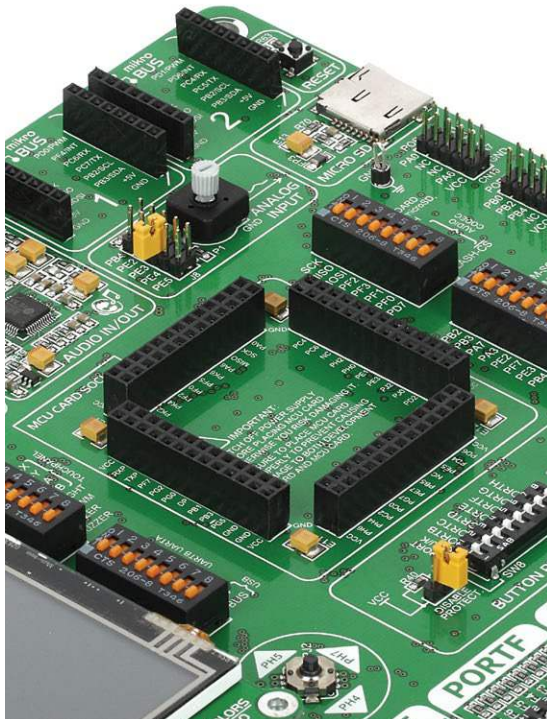

2

Figure 4-4: Place the MCU card on the socket so that pins are aligned correctly.

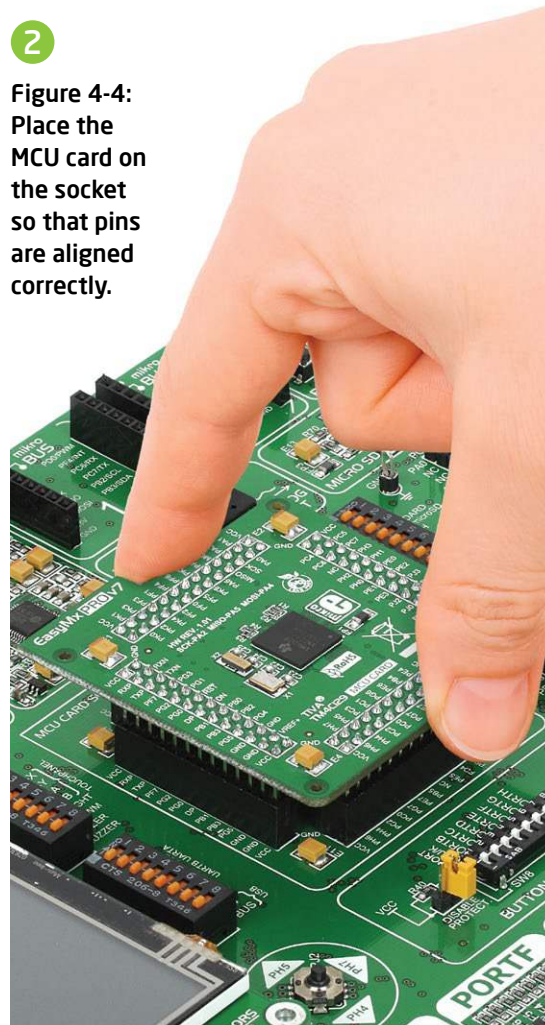

3

Figure 4-5 Properly placed MCU card.

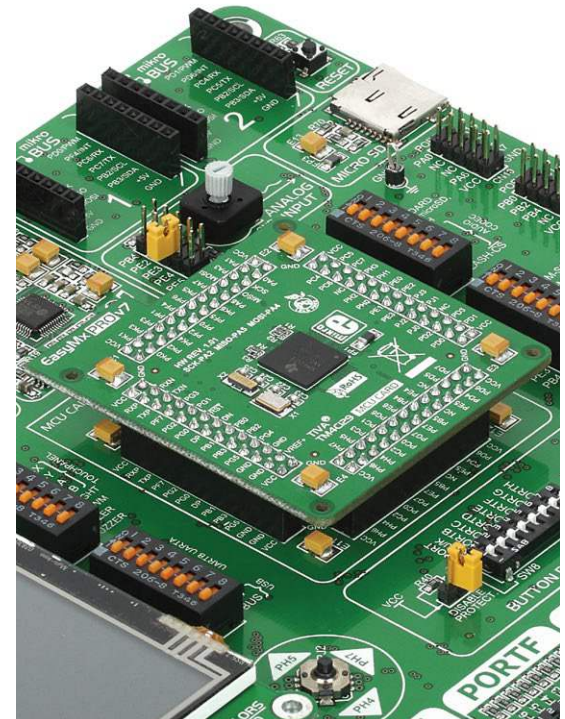

Other supported MCU cards

MikroElektronika currently offers a total of three populated MCU cards for the EasyMx for Tiva™ C Series: **TM4C129XNCZAD** microcontroller (default), **TM4C123GH6PZ** microcontroller and **TM4C123GH6PM** microcontroller. You can also purchase empty PCB cards that you can populate on

your own and solder any supported microcontroller you need in your development. There are a total of three empty PCB cards available. This way your EasyMx PRO™ v7 for Tiva™ C Series board becomes truly flexible and reliable tool for almost any of your Tiva™ C Series projects. MCU cards can also be used

in your final devices. For a complete list of currently available MCU cards, please visit the board webpage:



<http://www.mikroe.com/easymx-pro/tiva/>

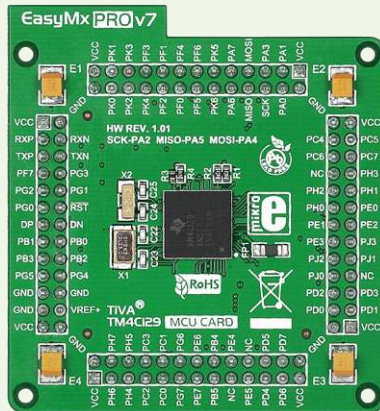

Default 212-pin MCU card with **TM4C129XNCZAD**

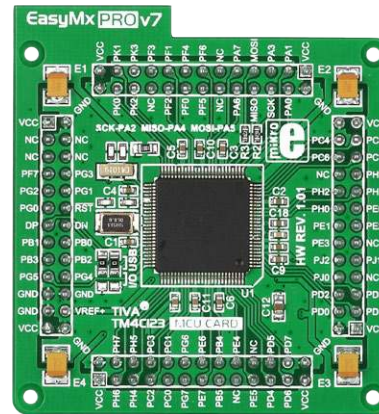

Standard 100-pin MCU card with **TM4C123GH6PZ**

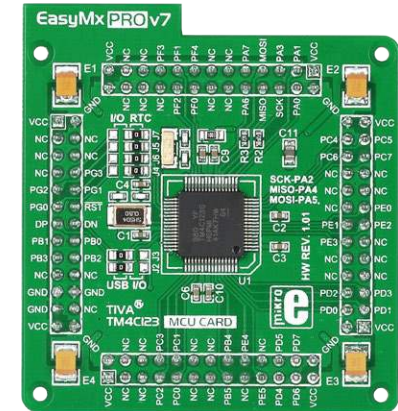

Standard 64-pin MCU card with **TM4C123GH6PM**

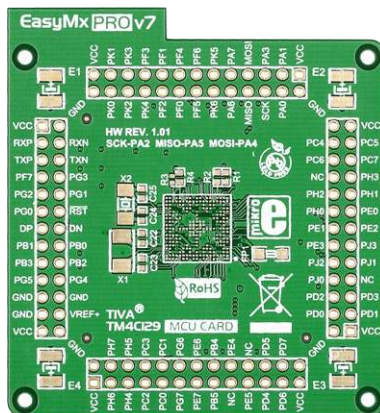

Empty MCU card for 212-pin **TM4C129** MCUs

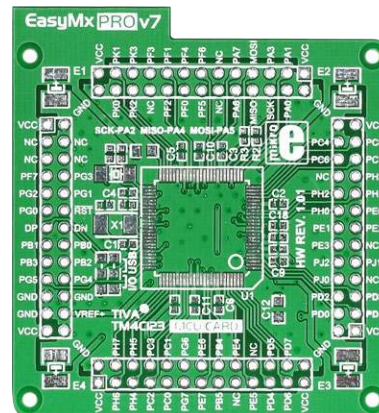

Empty MCU card for 100-pin **TM4C123** MCUs

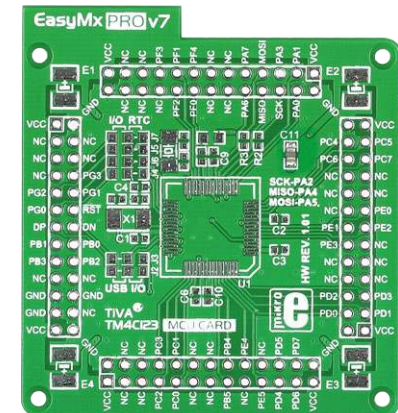

Empty MCU card for 64-pin **TM4C123** MCUs

On-board programmer

What is mikroProg™?

mikroProg™ is a fast programmer and debugger which is based on TI ICDI debugger. Smart engineering allows mikroProg™ to support over 55 ARM® Cortex™-M4 devices from Tiva™ C Series in a single programmer. It also features a powerful debugger which will be of great help in your development. Outstanding performance and easy operation are among its top features.

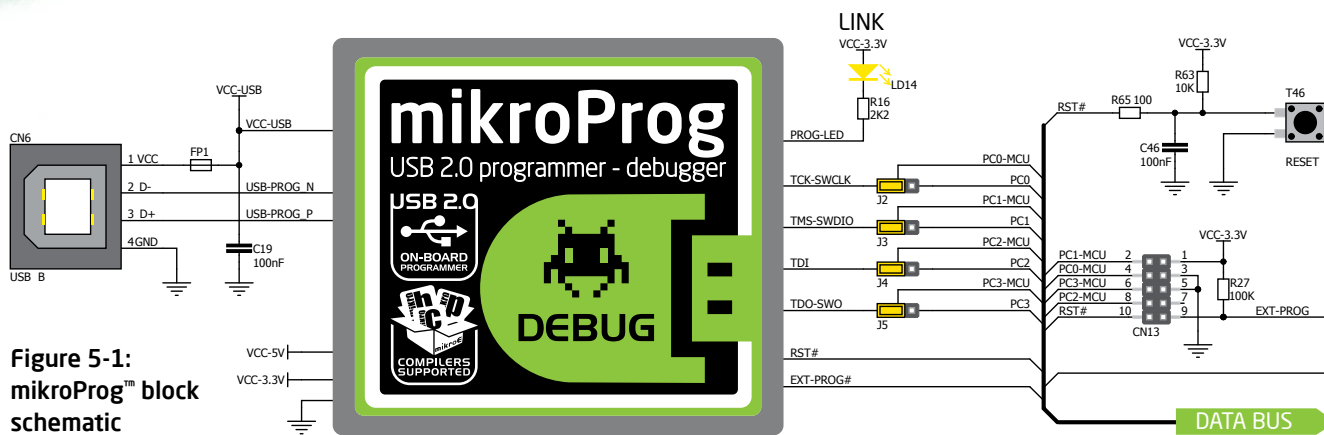

Figure 5-1: mikroProg™ block schematic

Cortex Debug



In addition to the on-board mikroProg programmer, there's also a Cortex Debug connector that supports JTAG debug, Serial Wire debug and Serial Wire Viewer operations.

How do I start?

In order to start using mikroProg™ and program your microcontroller, you just have to follow two simple steps:

- 1. Install the necessary software**
 - Install programmer drivers
 - Install mikroProg Suite™ for ARM® software
- 2. Power up the board, and you are ready to go**
 - Plug in the programmer USB cable
 - LINK LED should light up

Enabling mikroProg™

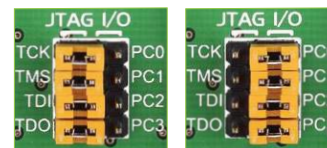

Five jumpers below the programmer USB connector are used to specify whether programming lines should be connected to programmer, or used as general purpose I/Os. If placed in **JTAG/SWD position**, jumpers connect **PC0-PC3** pins to TCK, TMS, TDI and TDO programming lines respectively and are cut off from the rest of the board.

Tiva™ C Series ARM® Cortex™ -M4 microcontrollers supported with mikroProg™

TM4C1230C3PM	TM4C1232H6PM	TM4C1237E6PZ	TM4C123GH6PZ
TM4C1230D5PM	TM4C1233C3PM	TM4C1237H6PM	TM4C1290NCZAD
TM4C1230E6PM	TM4C1233D5PM	TM4C1237H6PZ	TM4C1292NCZAD
TM4C1230H6PM	TM4C1233D5PZ	TM4C123AE6PM	TM4C1294NCZAD
TM4C1231C3PM	TM4C1233E6PM	TM4C123AH6PM	TM4C1297NCZAD
TM4C1231D5PM	TM4C1233E6PZ	TM4C123BE6PM	TM4C1299KCZAD
TM4C1231D5PZ	TM4C1233H6PM	TM4C123BE6PZ	TM4C1299NCZAD
TM4C1231E6PM	TM4C1233H6PZ	TM4C123BH6PM	TM4C129CNCZAD
TM4C1231E6PZ	TM4C1236D5PM	TM4C123BH6PZ	TM4C129DNCZAD
TM4C1231H6PM	TM4C1236E6PM	TM4C123FE6PM	TM4C129ENCZAD
TM4C1231H6PZ	TM4C1236H6PM	TM4C123FH6PM	TM4C129LNCZAD
TM4C1232C3PM	TM4C1237D5PM	TM4C123GE6PM	TM4C129XKCZAD
TM4C1232D5PM	TM4C1237D5PZ	TM4C123GE6PZ	TM4C129XNCZAD
TM4C1232E6PM	TM4C1237E6PM	TM4C123GH6PM	

About Texas Instruments Tiva™ C Series

Building on more than 20 years of experience developing leading microcontroller technology and ARM®-based processors, Texas Instruments launched the Tiva™ ARM® MCU platform in 2013, with Tiva™ C Series TM4C123x ARM Cortex-M4 MCUs.

These are the first Cortex-M-based MCUs to be built on 65 nanometer flash process technology, setting the roadmap to higher speeds, larger memory and lower power. The Tiva™ C Series TM4C123x MCUs are ideal for home, building and industrial automation.

The ARM Cortex-M4 floating-point core Tiva™ C Series MCUs strike a perfect balance between performance and power consumption. They eliminate performance tradeoffs with 12-bit ADC accuracy, achievable at the full 1 MSPS rating without any hardware averaging. And with low-power standby currents as low as 1.6 uA, they enable longer battery life and support constrained power budgets.

Installing programmer drivers

On-board mikroProg™ requires drivers in order to work. Drivers are located on the link below:



www.mikroe.com/downloads/get/1810/mikroprog_ti_drivers_v130.zip

When you locate the drivers, please extract the setup file from the ZIP archive. You should be able to locate the driver setup file. Double click the setup file to begin the installation of the programmer drivers.

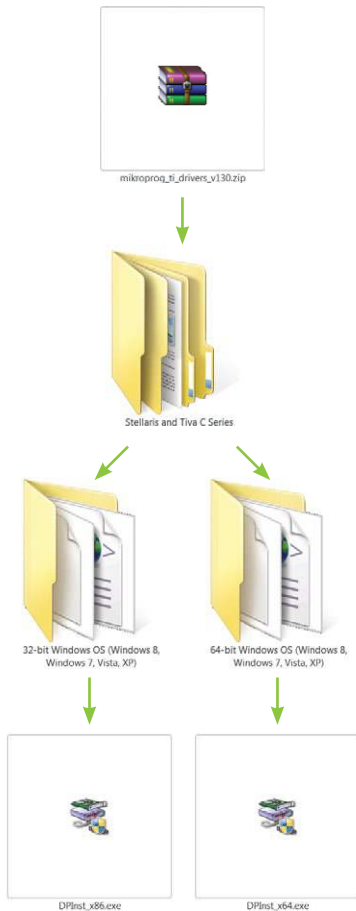

Step 1 - Start installation

Welcome screen of the installation. Just click **Next** to proceed.



Step 2 - Accept EULA

Make sure to understand and accept End User License Agreement before moving to next step.



Step 3 - Finish installation

You will be informed if the drivers are installed correctly. Click **Finish** to end the installation process.

Programming software

mikroProg Suite™ for ARM®

On-board mikroProg™ for Tiva™ C Series programmer requires **special programming software** called mikroProg Suite™ for ARM®. This software is used for programming all Tiva™ C Series microcontrollers. It features an intuitive interface and Single Click™ programming technology. Software installation is available on following link:



http://www.mikroe.com/downloads/get/1809/mikroprog_suite_for_arm_v130.zip

After downloading, extract the package and double click the executable setup file to start the installation.



Quick guide

- 1 Click the **Detect MCU** button in order to recognize the device ID.
- 2 Click the **Read** button to read the entire microcontroller memory. You can click the **Save** button to save it to target HEX file.
- 3 If you want to write the HEX file into the microcontroller, first make sure to load the target HEX file using the **Load** button. Then click the **Write** button to begin programming.
- 4 Click the **Erase** button to clear the microcontroller memory.

Figure 5-2: mikroProg Suite™ for ARM® window

Installation wizard - 6 simple steps



Step 1 - Start installation



Step 2 - Accept EULA and continue

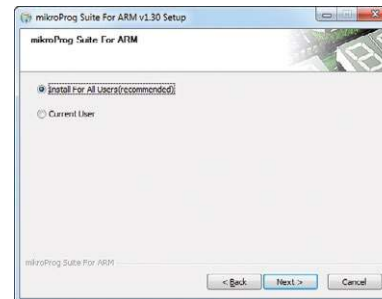

Step 3 - Install for all users or current user

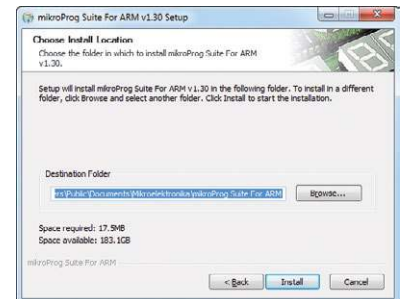

Step 4 - Choose destination folder

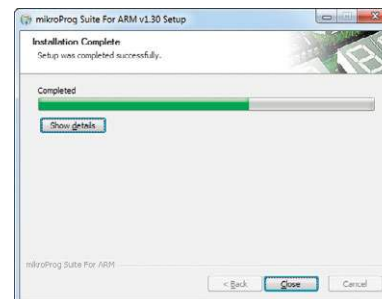

Step 5 - Installation in progress



Step 6 - Finish installation

Hardware debugger

What is debugging?

Every developer comes to a point when it's necessary to monitor code execution in order to find errors in the code, or simply to see if everything is going as planned. This hunt for bugs or errors in the code is called **debugging**. There are two ways to do this: one is **software simulation**, which enables you to simulate what is supposed to be happening on the microcontroller as your code lines are executed, and the other, more reliable one, is monitoring the code execution on the chip itself. And this latter one is called **hardware debugging**. "Hardware" means that it is the real deal - code executes right on the target device.

What is a hardware debugger?

The on-board **mikroProg™** programmer supports **hardware debugger** - a highly effective tool for **Real-Time debugging** on hardware level. The debugger enables you to execute your program on the host Tiva™ C Series microcontroller and view variable values, Special Function Registers (SFR), RAM, CODE and EEPROM memory along with the code execution on hardware. Whether you are a beginner or a professional, this powerful tool, with an intuitive interface and a convenient set of commands will enable you to track down bugs quickly. mikroProg debugger is one of the fastest, and most reliable debugging tools on the market.

Supported compilers

All MikroElektronika compilers, **mikroC™**, **mikroBasic™** and **mikroPascal™** for ARM®, natively support mikroProg™ for Tiva™ C Series, as well as other compilers, including KEIL®, IAR®. Specialized DLL module allows compilers to exploit the full potential of fast hardware debugging. Along with compilers, make sure to install the appropriate **programmer drivers** and **mikroProg Suite™ for ARM®** programming software, as described on **pages 14** and **15**.

How do I use the debugger?

When you build your project for debugging, and program the microcontroller with this HEX file, you can start the debugger using **[F9]** command. The compiler layout will switch to Debugging View, and a blue line will mark where code execution is currently paused. Use the **debugging toolbar** in the **Watch Window** to guide the program execution, and stop anytime. Add the desired variables to the Watch Window and monitor their values.

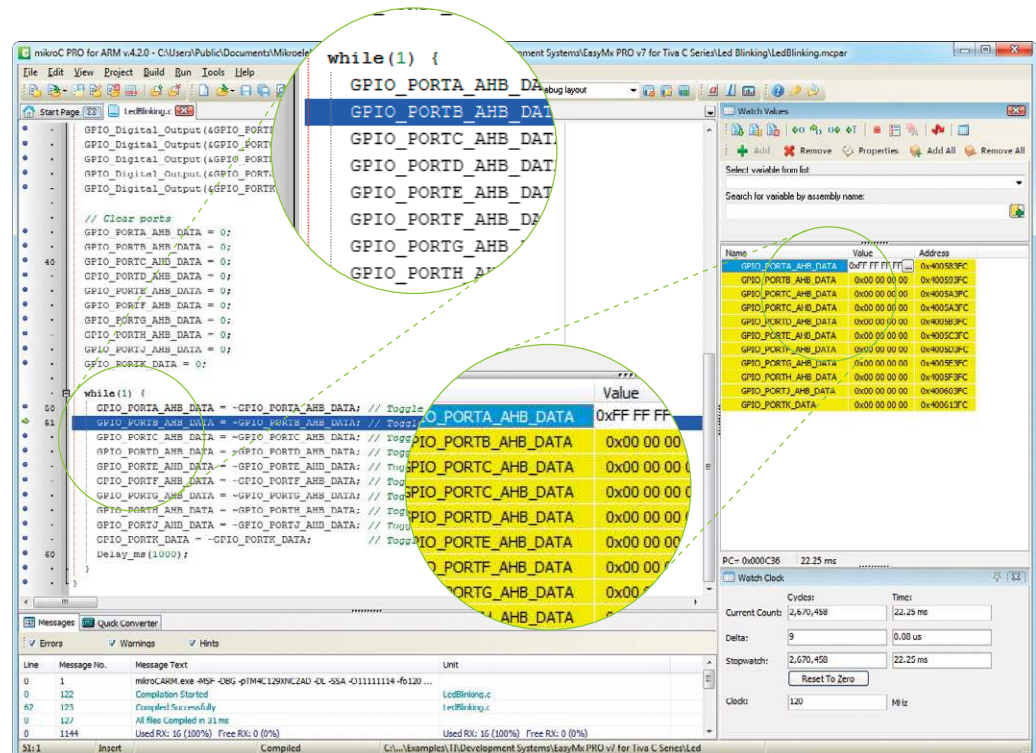

Figure 5-3: mikroC PRO for ARM® compiler in debugging view, with SFR registers in Watch Window



Debugger commands



Here is a short overview of which debugging commands are supported in MikroElektronika compilers. You can see what each command does, and what are their shortcuts when you are in debugging mode. It will give you a general picture of what your debugger can do.

Toolbar Icon	Command Name	Shortcut	Description
	Start Debugger	[F9]	Starts Debugger.
	Run/Pause Debugger	[F6]	Run/Pause Debugger.
	Stop Debugger	[Ctrl + F2]	Stops Debugger.
	Step Into	[F7]	Executes the current program line, then halts. If the executed program line calls another routine, the debugger steps into the routine and halts after executing the first instruction within it.
	Step Over	[F8]	Executes the current program line, then halts. If the executed program line calls another routine, the debugger will not step into it. The whole routine will be executed and the debugger halts at the first instruction following the call.
	Step Out	[Ctrl + F8]	Executes all remaining program lines within the subroutine. The debugger halts immediately upon exiting the subroutine.
	Run To Cursor	[F4]	Executes the program until reaching the cursor position.
	Toggle Breakpoints	[F5]	Toggle breakpoints option sets new breakpoints or removes those already set at the current cursor position.
	Show/Hide breakpoints	[Shift+F4]	Shows/Hides window with all breakpoints
	Clears breakpoints	[Shift+Ctrl+F5]	Delete selected breakpoints
	Jump to interrupt	[F2]	Opens window with available interrupts (doesn't work in hardware debug mode)

Input/Output group

One of the most distinctive features of EasyMx PRO™ v7 for Tiva™ C Series are its Input/Output PORT groups. They add so much to the connectivity potential of the board.

Everything is grouped together

PORT **headers**, PORT **buttons** and PORT **LEDs** are next to each other and grouped together. This layout gives the EasyMX PRO for Tiva™ C Series a clean, well organized look and it makes development easier. We have also provided **additional PORT headers** on the right side of the board, so you can access any pin you want from that side of the board too.

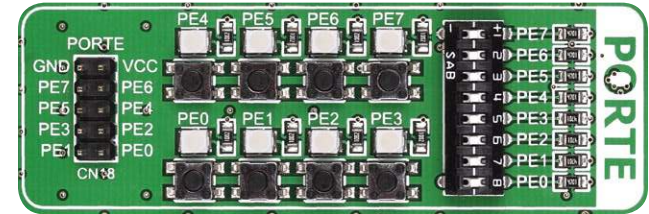

Figure 6-1: I/O group contains PORT header, tri-state pull up/down DIP switch, buttons and LEDs all in one place

Tri-state pull-up/down DIP switches

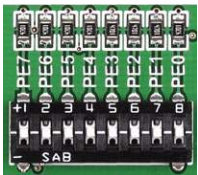
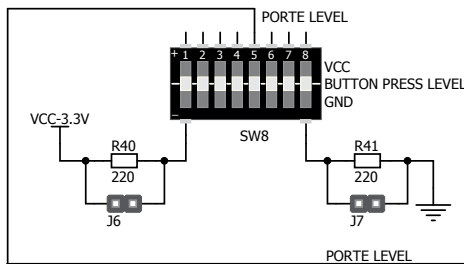

Figure 6-2: Tri-state DIP switch on PORTE

Tri-state DIP switches, like **SW7** on **Figure 6-2**, are used to enable 4K7 pull-up or pull-down resistor on any desired port pin. Each of these switches has three states:

1. **middle position** disables both pull-up and pull-down feature from the PORT pin
2. **up position** connects the resistor in pull-up state to the selected pin
3. **down position** connects the resistor in pull-down state to the selected PORT pin.



Button press level tri-state DIP switch is used to determine which logic level will be applied to port pins when buttons are pressed

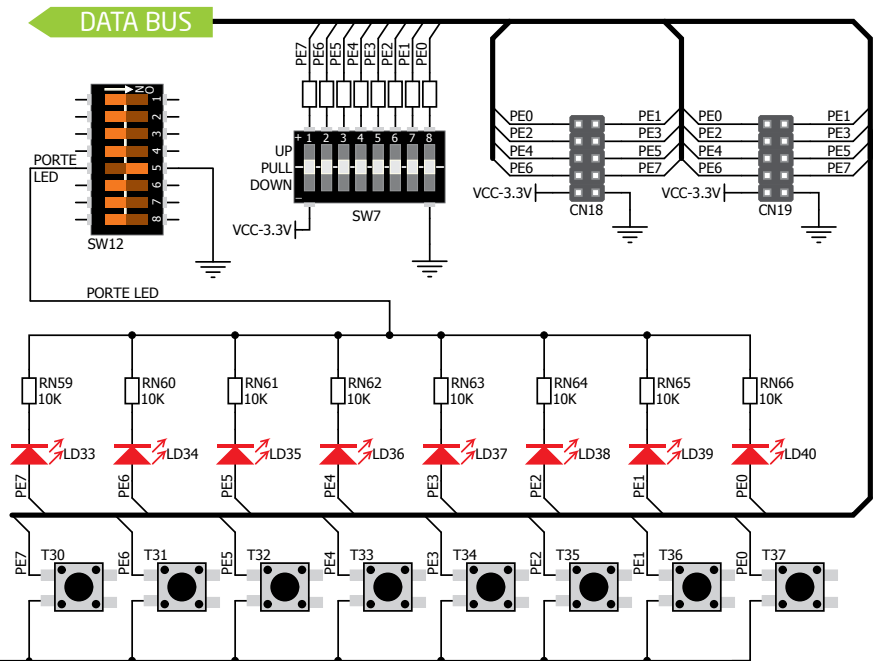
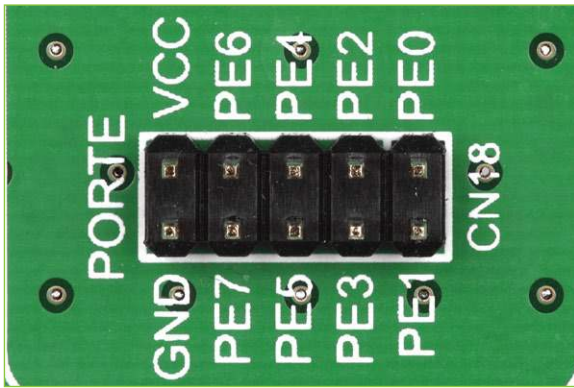

Figure 6-3: Schematic of the single I/O group connected to microcontroller PORTE



Headers

Enhanced connectivity is one of the key features of EasyMx PRO™ v7 for Tiva™ C Series. That's why we have provided **two connection headers for each PORT**. I/O PORT group contains one IDC10 header (like **CN18** **Figure 6-3**). There is **one more IDC10 header** available on the right side of the board, next to DIP switches (like **CN19** on **Figure 6-3**). These headers can be used to connect accessory boards with IDC10 sockets.

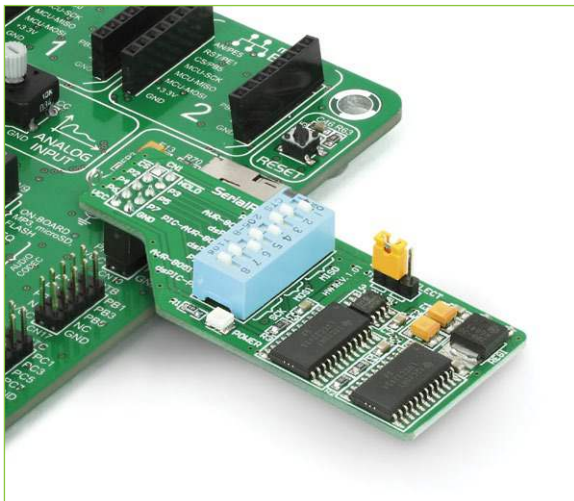
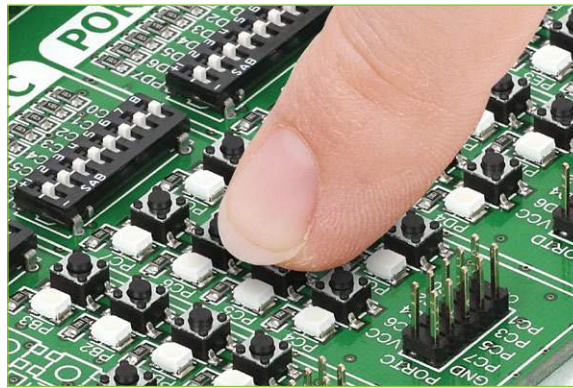

Figure 6-4: IDC10 headers enable easy connection with MikroElektronika accessory boards



Buttons

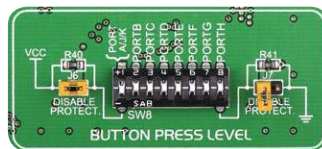
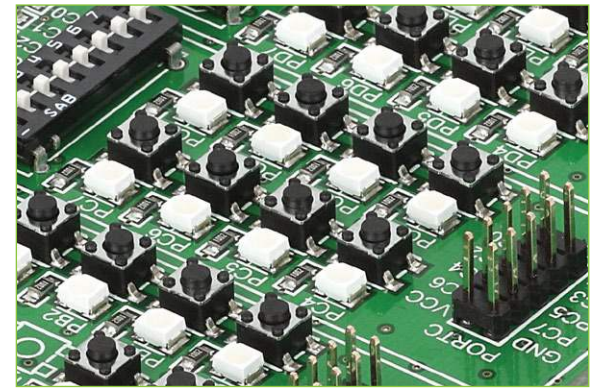

Figure 6-5: Button press level DIP switch (tri-state)

The logic state of all microcontroller digital inputs may be changed using **push buttons**. Tri-state DIP switch **SW8** is available for selecting which logic state will be applied to corresponding MCU pin when button is pressed, for each I/O port separately. If you, for example, place **SW8.5** in **VCC** position, then pressing of any push button in PORTE I/O group will apply logic one to the appropriate microcontroller pin. The same goes for **GND**. If DIP switch is in the middle position neither of two logic states will be applied to the appropriate microcontroller pin. You can disable pin protection 220ohm resistors by placing jumpers **J6** and **J7**, which will connect your push buttons directly to VCC or GND. Be aware that by doing so you may accidentally damage MCU in case of wrong usage.

Reset button

In the far upper right section of the board, there is a **RESET button**, which can be used to manually reset the microcontroller.



LEDs

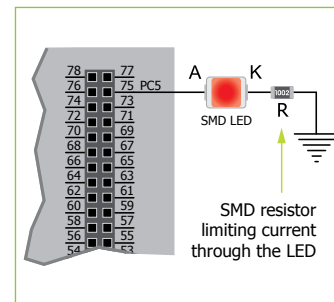

LED (Light-Emitting Diode) is a highly efficient electronic light source. When connecting LEDs, it is necessary to place a current limiting resistor in series so that LEDs are provided with the current value specified by the manufacturer. The current varies from 0.2mA to 20mA, depending on the type of LED and the manufacturer. The EasyMx PRO™ v7 for Tiva™ C Series board uses low-current LEDs with typical current consumption of 0.2mA or 0.3mA. Board contains 67 LEDs which can be used for visual indication of the logic state on PORT pins. An active LED indicates that a logic high (1) is present on the pin. In order to enable PORT LEDs, it is necessary to enable the corresponding DIP switch on **SW12** (**Figure 6-6**).

The current varies from 0.2mA to 20mA, depending on the type of LED and the manufacturer. The EasyMx PRO™ v7 for Tiva™ C Series board uses low-current LEDs with typical current consumption of 0.2mA or 0.3mA. Board contains 67 LEDs which can be used for visual indication of the logic state on PORT pins. An active LED indicates that a logic high (1) is present on the pin. In order to enable PORT LEDs, it is necessary to enable the corresponding DIP switch on **SW12** (**Figure 6-6**).

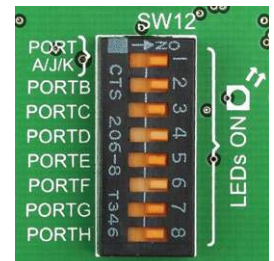

Figure 6-6: SW12.1 through SW12.8 switches are used to enable PORT LEDs

mikroBUS™ sockets

Easier connectivity and simple configuration are imperative in modern electronic devices. Success of the USB standard comes from its simplicity of usage and high and reliable data transfer rates. As we in MikroElektronika see it, plug-and-play devices with minimum settings are the future in the embedded world too. That is why our engineers came up with a simple, but brilliant pinout with lines that most of today's accessory boards require, which almost completely eliminates the need for additional hardware settings. We called this new standard the **mikroBUS™**. EasyMx PRO™ v7 for Tiva™ C Series supports mikroBUS™ with two on-board sockets. As you can see, there are no additional DIP switches, or jumper selections. Everything

is already routed to the most appropriate pins of the microcontroller sockets.

mikroBUS™ host connector

Each mikroBUS™ host connector consists of two 1x8 female headers containing pins that are most likely to be used in the target accessory board. There are three groups of communication pins: **SPI**, **UART** and **I²C** communication. There are also single pins for **PWM**, **Interrupt**, **Analog input**, **Reset** and **Chip Select**. Pinout contains two power groups: **+5V** and **GND** on one header and **+3.3V** and **GND** on the other 1x8 header.

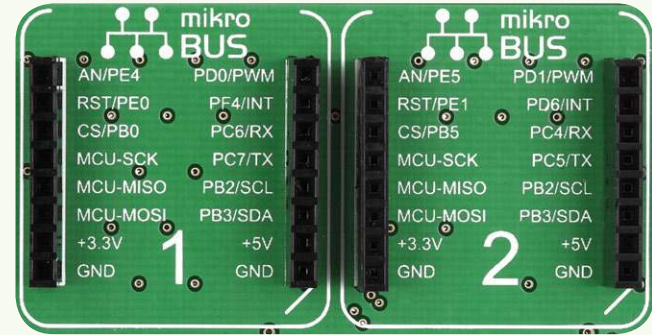

mikroBUS™ pinout explained

- | | |
|-------------------------------------|--|
| AN - Analog pin | PWM - PWM output line |
| RST - Reset pin | INT - Hardware Interrupt line |
| CS - SPI Chip Select line | RX - UART Receive line |
| SCK - SPI Clock line | TX - UART Transmit line |
| MISO - SPI Slave Output line | SCL - I ² C Clock line |
| MOSI - SPI Slave Input line | SDA - I ² C Data line |
| +3.3V - VCC-3.3V power line | +5V - VCC-5V power line |
| GND - Reference Ground | GND - Reference Ground |

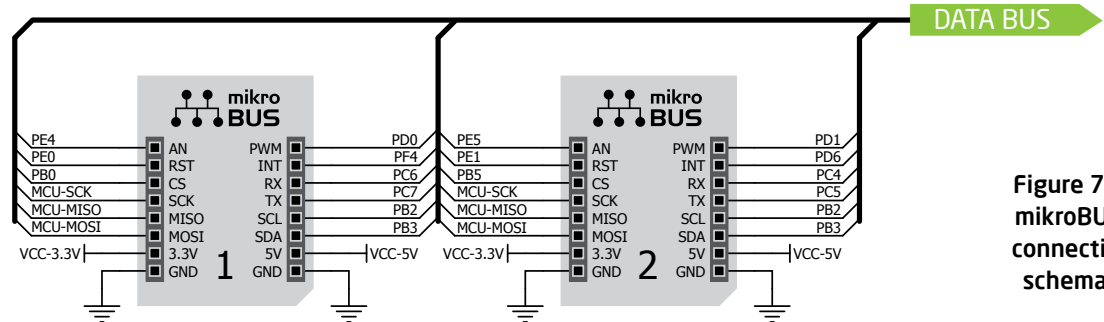
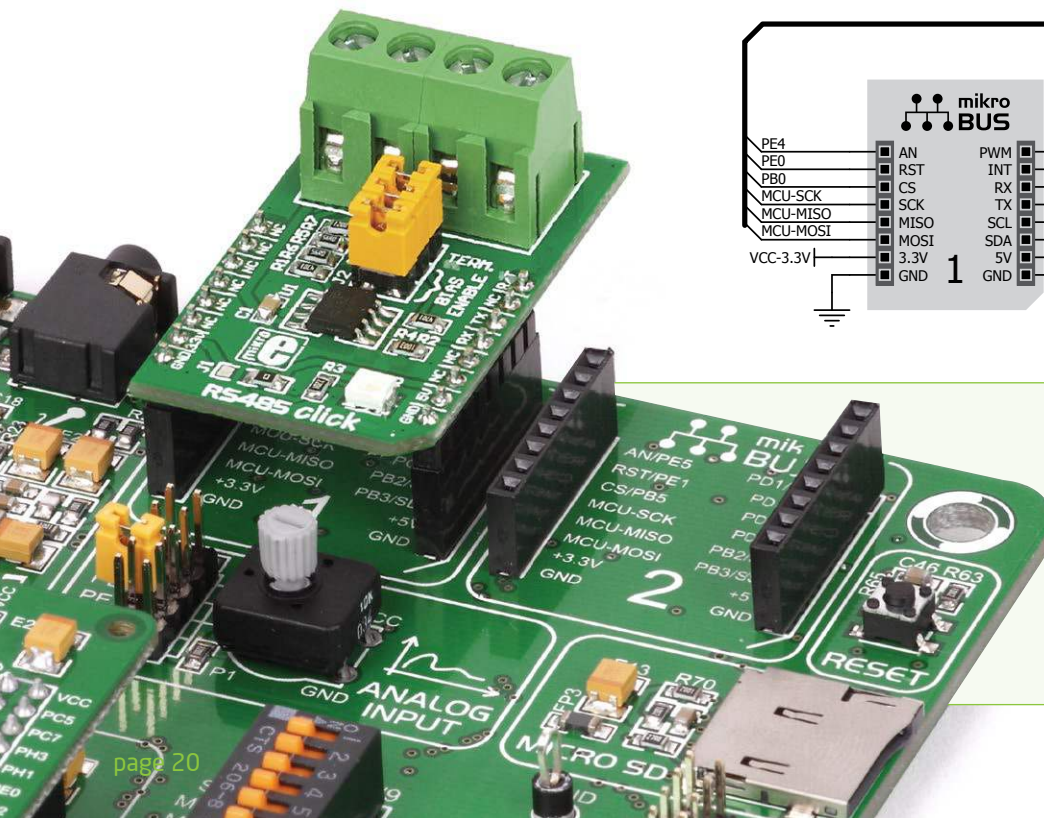

Figure 7-1: mikroBUS™ connection schematic

Integrate mikroBUS™ in your design

mikroBUS™ is not made only to be a part of our development boards. You can freely place mikroBUS™ host connectors in your final PCB designs, as long as you clearly mark them with the mikroBUS™ logo and footprint specifications. For more information, logo artwork and PCB files visit our website:



<http://www.mikroe.com/mikrobus/>



CC3000 click™

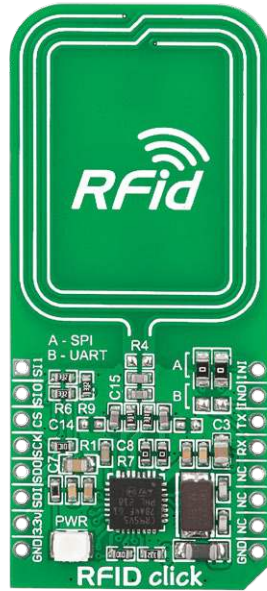

RFID click™



Bluetooth click™

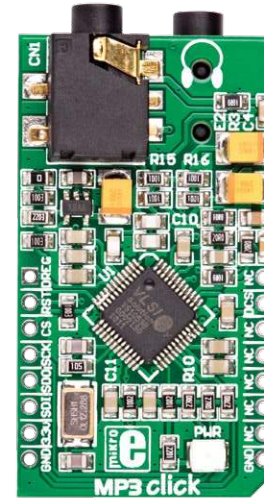

MP3 click™



GSM click™

click™ boards are plug-and-play!

MikroElektronika's portfolio of over 200 accessory boards is now enriched by an additional set of mikroBUS™ compatible **click™ boards**. Almost each month several new click™ boards are released. It is our intention to provide the community with as much of these boards as possible, so you will be able to expand your EasyMX™ PRO v7 for Tiva™ C Series with additional functionality with literally

zero hardware configuration. Just plug and play. Visit the click™ boards webpage for the complete list of available boards:



<http://www.mikroe.com/click/>

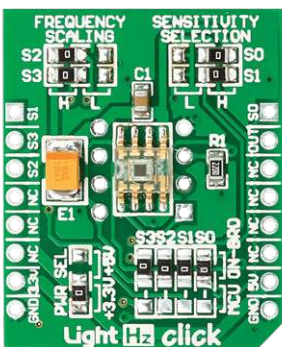

LightHz click™



microSD click™

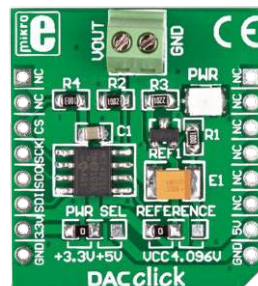

DAC click™

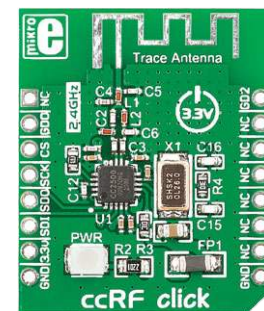

ccRF click™

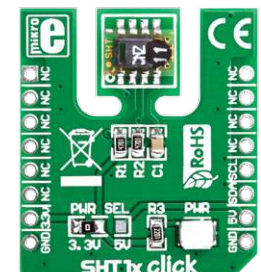

SHT1x click™

USB-UART A



Enabling USB-UART A

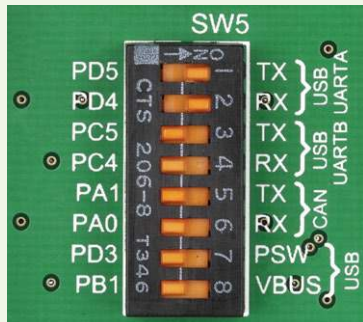

In order to enable USB-UART A communication, you must push **SW5.1** (PD5) and **SW5.2** (PD4) to **ON** position. This connects the **RX** and **TX** lines to **PD5** and **PD4** microcontroller pins.

The **UART** (universal asynchronous receiver/transmitter) is one of the most common ways of exchanging data between the MCU and peripheral components. It is a serial protocol with separate transmit and receive lines, and can be used for full-duplex communication. Both sides must be initialized with the same baud rate, otherwise the data will not be received correctly.

Modern PC computers, laptops and notebooks are no longer equipped with RS-232 connectors and UART controllers. They are nowadays replaced with USB connectors and USB controllers. Still, certain technology enables UART communication to be done via USB connection. Controllers such as **FT232RL** from FTDI® convert UART signals to the appropriate USB standard.

USB-UART A communication is realized through a FT232RL controller, USB connector (**CN12**), and the microcontroller UART module. To establish this connection, you must connect **TX** and **RX** lines of the FT232RL to the appropriate pins of the microcontroller. This selection is done using DIP switches **SW5.1** and **SW5.2**.

In order to use USB-UART A module on EasyMx PRO™ v7 for Tiva™ C Series, you must first install FTDI drivers on your computer. Drivers can be found on link below:



<http://www.ftdichip.com/Drivers/VCP.htm>

Figure 8-1:
USB-UART A
connection
schematic

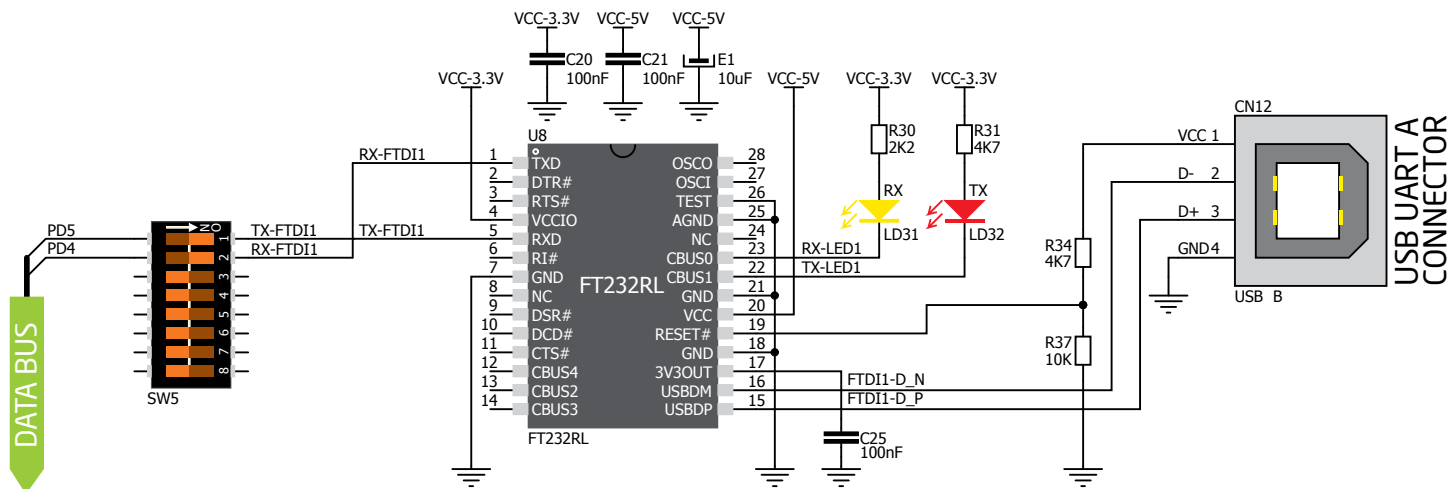

USB-UART B



Enabling USB-UART B

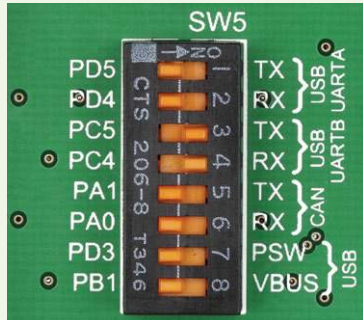

In order to enable USB-UART B communication, you must push **SW5.3** (PC5) and **SW5.4** (PC4) to **ON** position. This connects the **TX** and **RX** lines to **PD5** and **PD6** microcontroller pins.

If you need to use more than one USB-UART in your application, there's a second connector, **USB-UART B**, available on the board as well. Both available USB-UART modules can operate at the same time, because they are routed to separate microcontroller pins.

USB-UART B communication is realized through a FT232RL controller, USB connector (**CN20**), and microcontroller UART module. To establish this connection, you must connect **TX** and **RX** lines of the FT232RL to the appropriate pins of the microcontroller. This selection is done using DIP switches **SW5.3** and **SW5.4**

When using either USB-UART A or USB-UART B, make sure to disconnect all devices and additional boards that could interfere with the signals and possibly corrupt the sent or received data.

In order to use USB-UART B module on EasyMx PRO™ v7 for Tiva™ C Series, you must first install FTDI drivers on your computer. Drivers can be found on link below:



<http://www.ftdichip.com/Drivers/VCPhm>

Figure 9-1: USB-UART B connection schematic

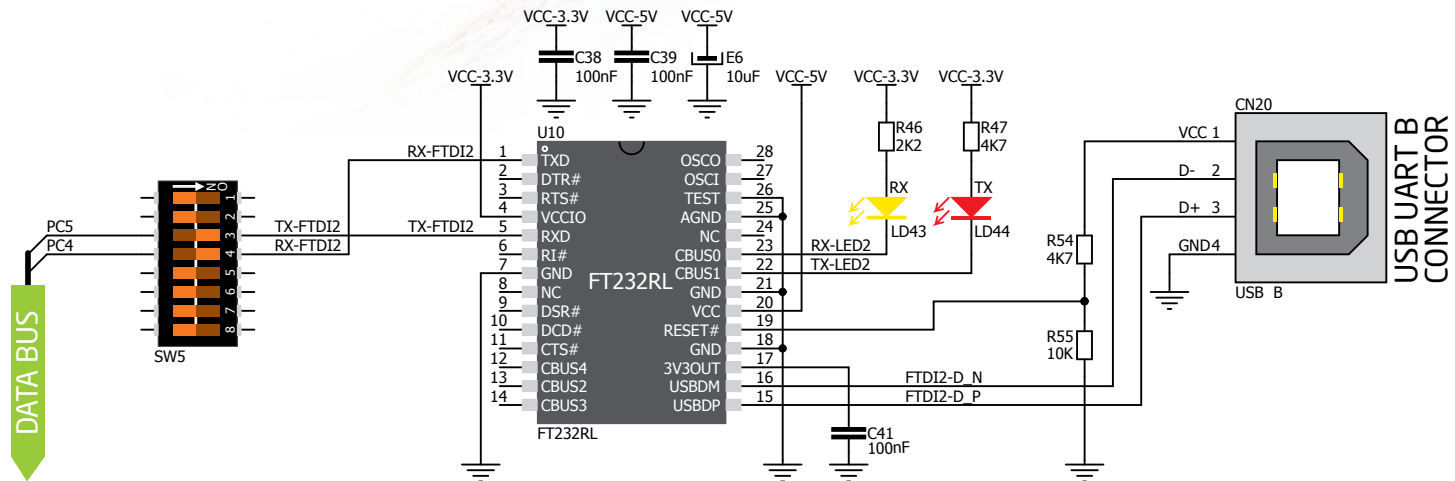

USB Host communication

USB is the acronym for **Universal Serial Bus**. This is a very popular industry standard that defines cables, connectors and protocols used for communication and power supply between computers and other devices. EasyMx PRO™ v7 for Tiva™ C Series contains USB Host connector (**CN21**) for a USB Standard Type A plug, which enables microcontrollers that support USB communications

to establish a connection with a target device (such as a USB Keyboard, a USB Mouse and so forth). USB Host also provides the necessary 5V power supply to the target via **TPS2041B** IC. Detecting whether the USB device is connected to the Host connector or not can be done through the **VBUS** line. Connection of USB Host is established when **SW5.7** and **SW5.8** are on.

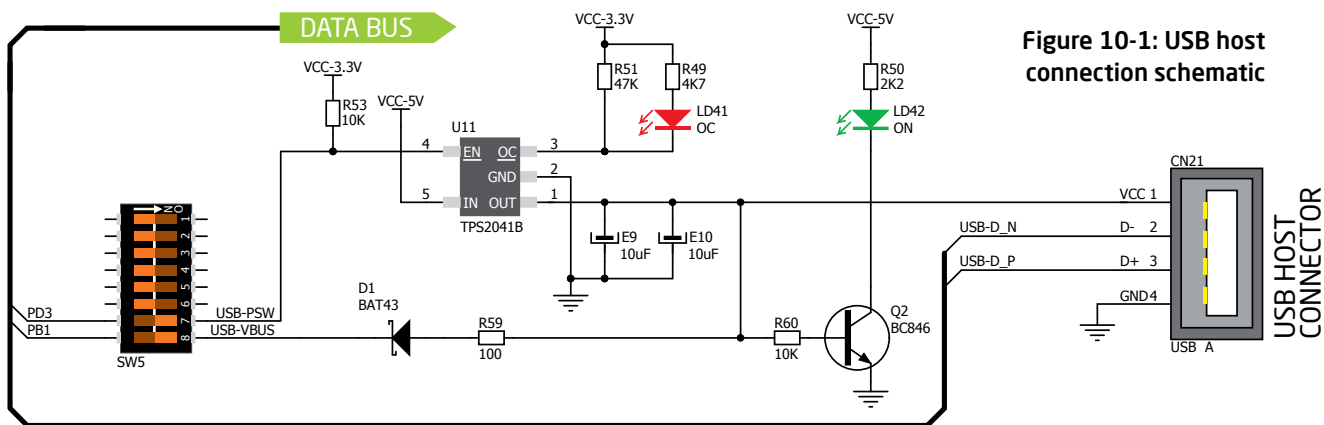

Figure 10-1: USB host connection schematic



Powering USB device

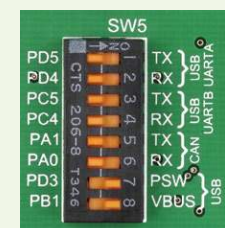

Figure 10-2: Powering USB device through PSW line

You can enable or disable power supply to USB device connected to Host, through microcontroller **PD3** and **BP1** pins. In order to connect EN TPS2041B IC pin to microcontroller, you must push **SW5.7** and **SW5.8** to **ON** position.

USB Device communication

EasyMx PRO™ v7 for Tiva™ C Series also contains a USB Device connector (**CN25**) which enables microcontrollers that support USB communications to establish a connection with a target host (such as PC, Laptop, and so forth). It lets you build a slave USB device (HID, Composite, Generic, and others). Connector supports a USB Standard

Type B plug. Detecting whether the USB device is connected to the host or not can be done through the **VBUS** line. This line is traced to microcontroller **PB1** pin. Connection of USB Device is established when **SW5.8** DIP switch is in ON position. When connected to a host a dedicated amber-colored power LED will light up as well. This VCC line cannot be used for powering the board. It's only used for detecting a connection.

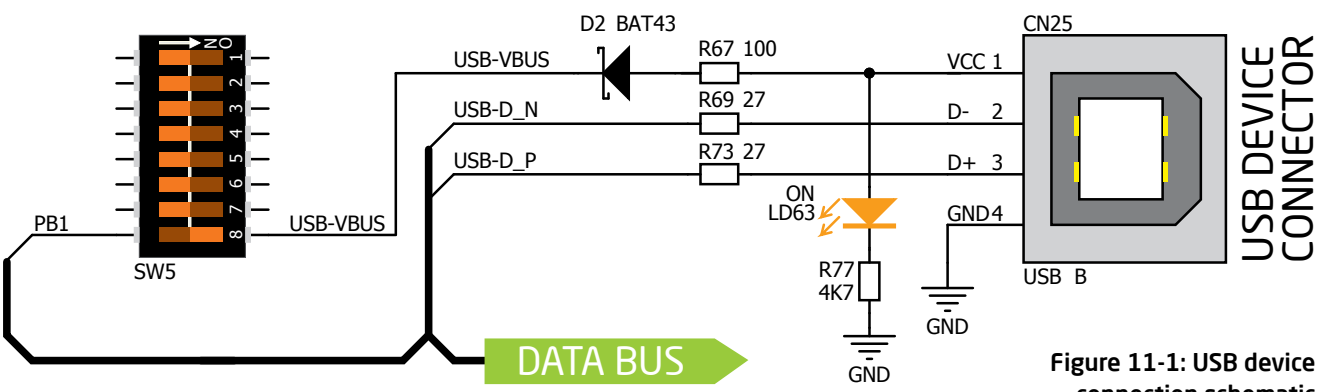

Figure 11-1: USB device connection schematic



Detecting connection

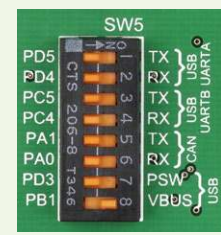

Figure 11-2: Enabling USB device detection via VBUS line

You can detect whether USB device is plugged into the USB device connector using **VBUS** power detection line (**PB1**). Before using this feature, you must connect **PB1** pin to USB connector using **SW5.8** DIP switch.



Ethernet communication

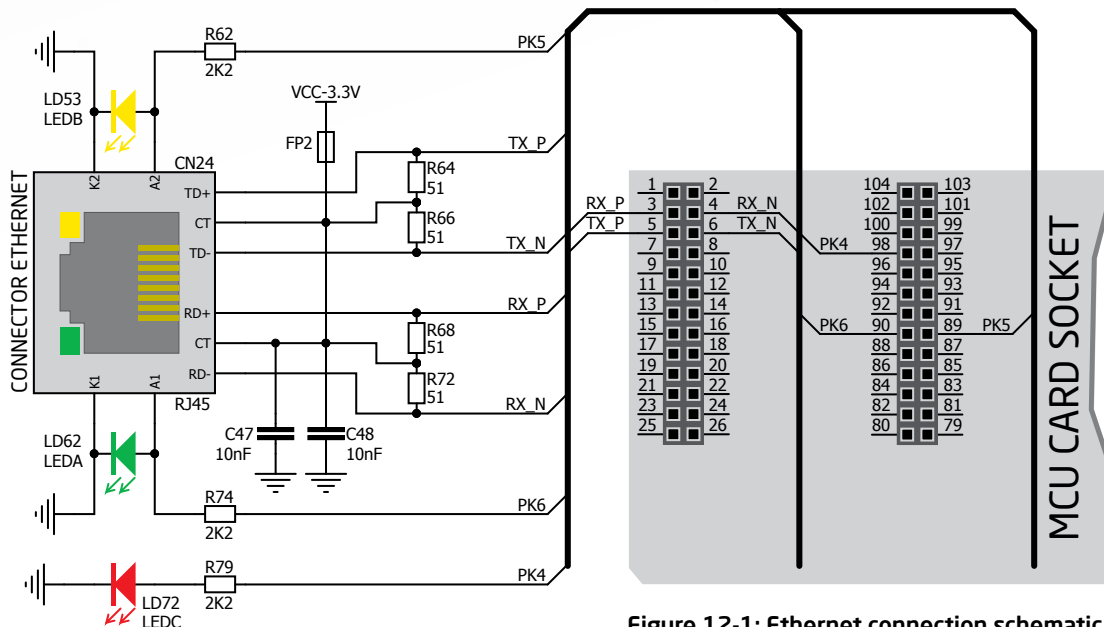

Figure 12-1: Ethernet connection schematic

Ethernet is a popular computer networking technology for local area networks (LAN). Systems communicating over Ethernet divide a stream of data into individual packets called frames. Each frame contains source and destination addresses and error-checking data so that damaged data can be detected and retransmitted.

EasyMx PRO™ v7 for Tiva™ C Series features a standard **RJ-45** connector which enables microcontrollers that support Ethernet communications to establish a connection with a computer, router or other devices.

All four Ethernet lines (TPOUT+, TPOUT-, TPIN+ and TPIN-) are routed directly to the MCU card socket and cannot be accessed via PORT headers. Additional signalization LEDs (red, green and yellow) are provided on the board next to the **RJ-45** connector.



CAN communication

Controller Area Network (CAN or CAN bus) is a vehicle bus standard designed to allow microcontrollers and devices to communicate with each other within a vehicle without a host computer. CAN is a message-based protocol, designed specifically for automotive applications but now also used in other areas such as industrial automation and medical equipment. EasyMx PRO™ v7 for Tiva™ C Series is equipped with **SN65HVD230** - a 3.3V CAN Transceiver and a pair of screw terminals which provide microcontrollers with an integrated CAN controller with the necessary physical interface for CAN communications. Make sure to correctly connect negative and positive differential communication lines before using this module.

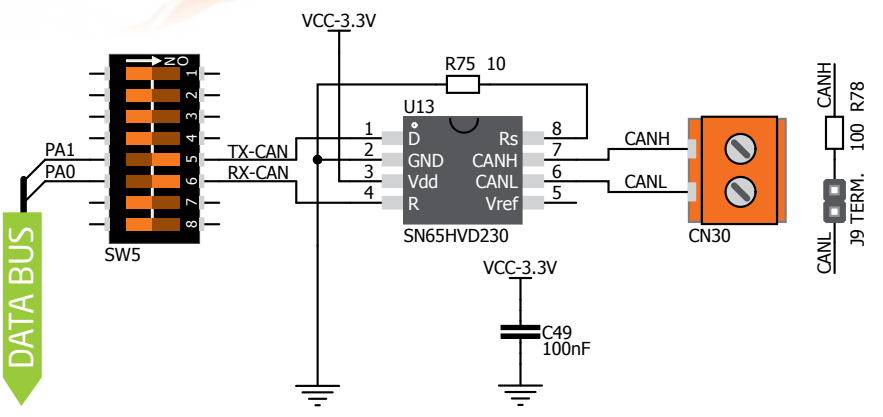

Figure 13-1: CAN connection schematic



Enabling CAN

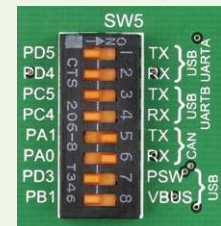

Figure 13-2: enabling CAN communication

In order to enable CAN communication, you must push **SW5.5** (PA1) and **SW5.6** (PA0) to **ON** position. This connects the **TX** and **RX** lines to appropriate microcontroller pins and its CAN module.

Audio I/O

It's hard to imagine modern multimedia devices without high quality audio reproduction modules. Sounds and music are almost as important as graphical user interfaces. Along with other multimedia modules, EasyMx PRO™ v7 for Tiva™ C Series carries a high-end stereo **VS1053** audio codec. It features an Ogg Vorbis/MP3/AAC/WMA/FLAC/WAV/MIDI **audio decoder**, as well as a PCM/IMA ADPCM/Ogg Vorbis **encoder** on a single chip. Board also contains **two stereo audio connectors** for interfacing with standard 3.5mm stereo audio jacks. VS1053 receives the input bit stream through a serial input bus, which it listens to as a system slave. The input stream is decoded and passed through a digital volume control to an 18-bit oversampling, multi-bit, sigma-delta Digital to Analog Converter (DAC). The decoding is controlled via a serial control bus. In addition to the basic decoding, it is possible to add application specific features like DSP effects to the user RAM memory. You can build music players, audio recording devices, internet radio player applications, and much more.

Figure 14-1: Audio IN/OUT connection schematic

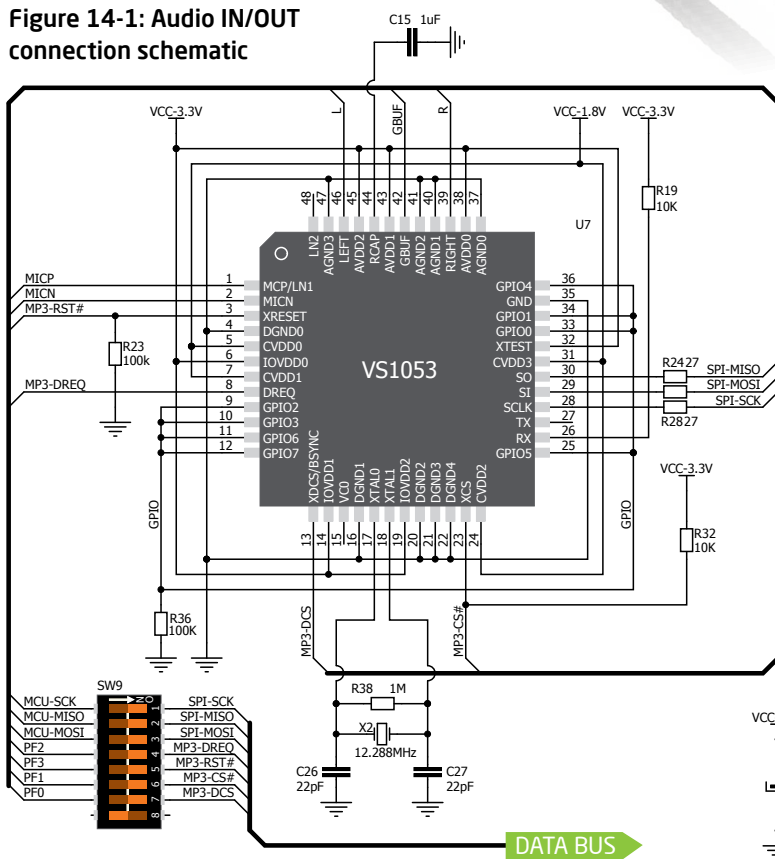

Enabling Audio I/O



Figure 14-2: Enabling audio codec communication lines

In order to use Audio I/O module, you must connect data and Audio control lines of the microcontroller with the VS1053 audio codec. To do this, push **SW9.1-SW9.7** switches to **ON** position. This will connect SPI data lines with MCU_SCK, MCU_MISO and MCU_MOSI microcontroller pins, and audio control and chip select lines with PF2, PF3, PF1 and PF0 pins.

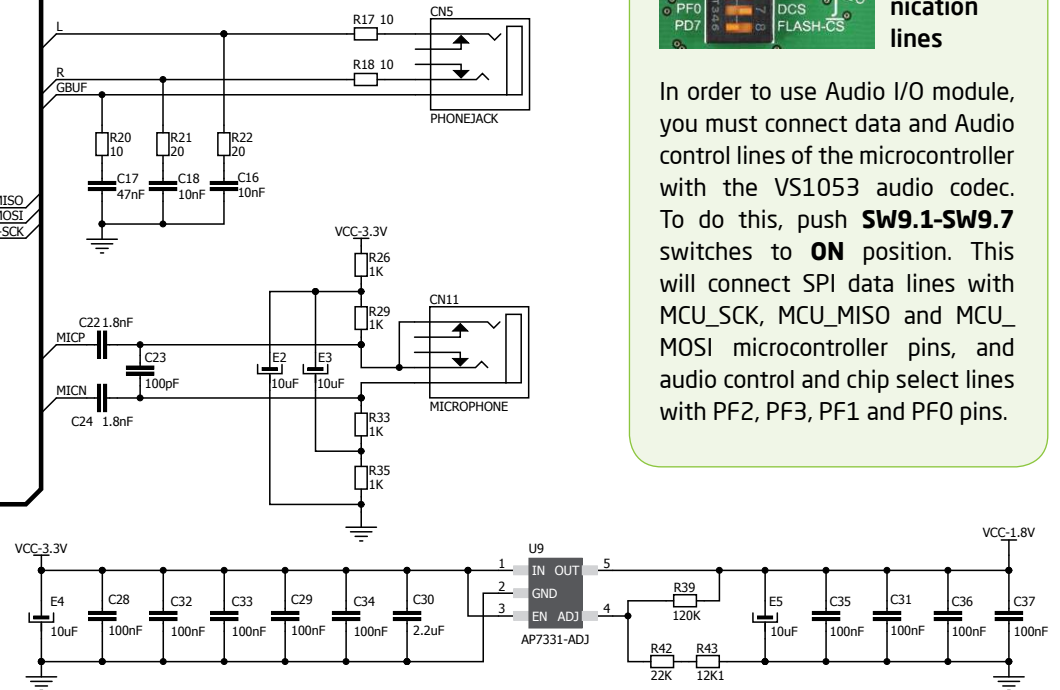

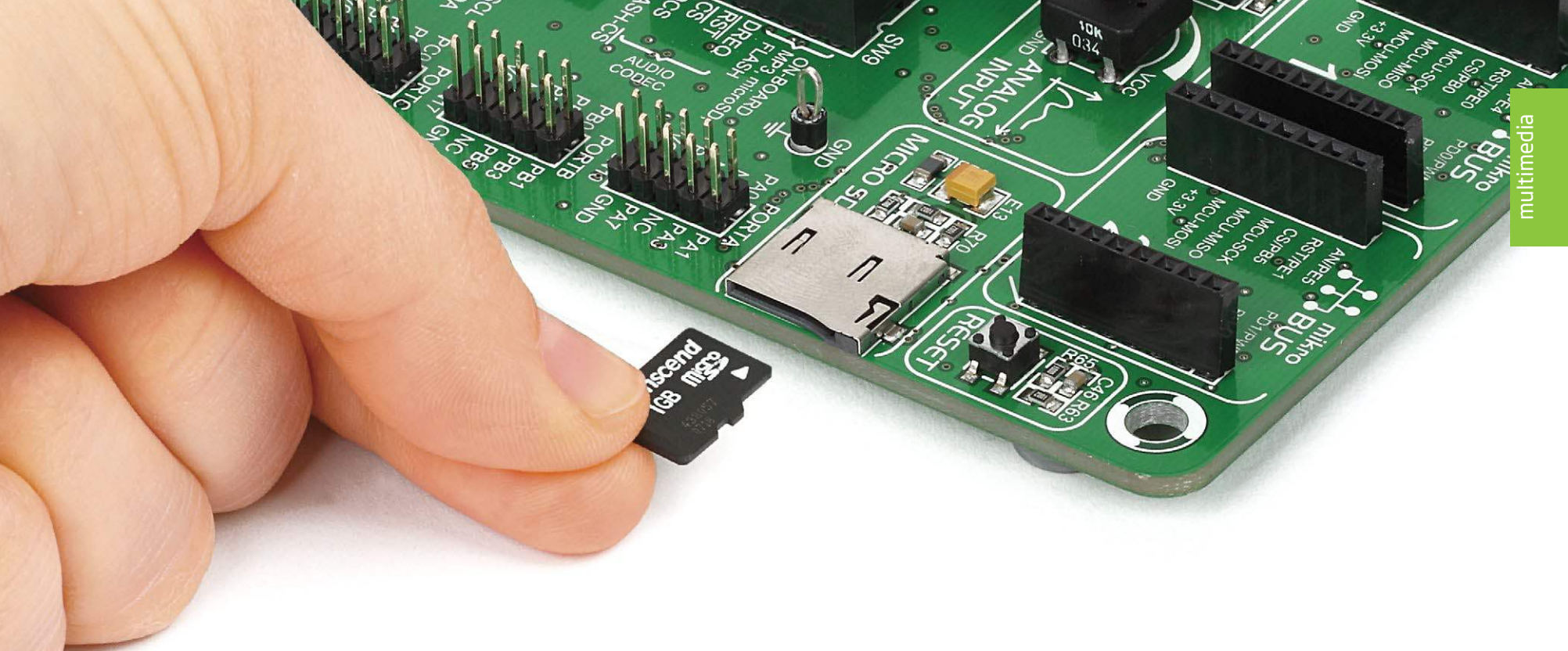

microSD card slot

Secure Digital (SD) is a non-volatile memory card format developed for use in portable devices. It comes in different packages and memory capacities. It is mostly used for storing large amounts of data. EasyMx PRO™ v7 for Tiva™ C Series features a **microSD card slot**. The microSD form factor is the smallest card format currently available. It uses a standard SPI user interface with minimum additional electronics, mainly used for stabilizing communication lines which can be significantly distorted at high transfer rates. Special ferrite is also provided to compensate the voltage and current glitch that can occur when pushing-in and pushing-out a microSD card into the socket.

Enabling microSD

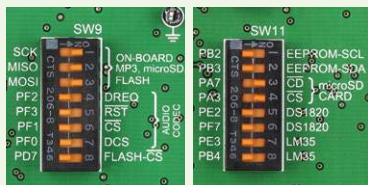

In order to access your microSD card, you must enable SPI communication lines using **SW9.1 - SW9.3** DIP switches, as well as Chip Select (\overline{CS}) and Card Detect (\overline{CD}) lines using **SW11.3** and **SW11.4** switches.

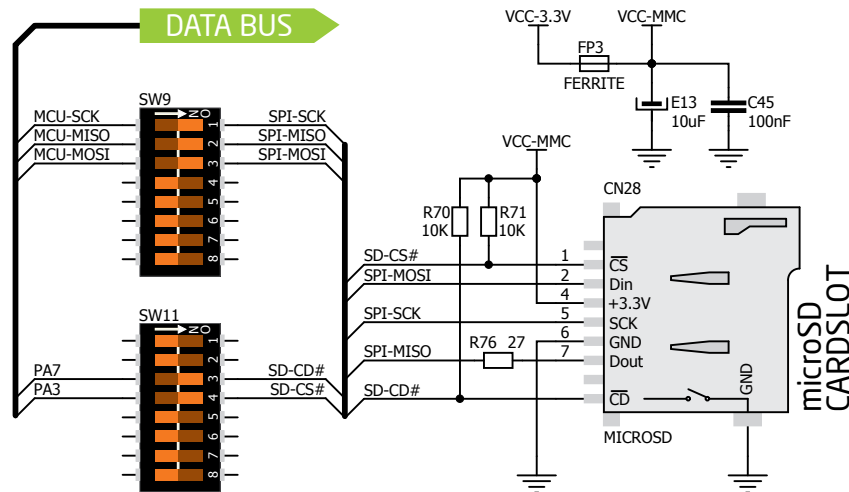

Figure 15-1: microSD card slot connection schematic



multimedia

TFT display 320x240 pixels

One of the most powerful ways of presenting data and interacting with users is through color displays and touch panel inputs. This is a crucial element of any multimedia device. EasyMx PRO™ v7 for Tiva™ C Series features a EasyTFT board carrying a 320x240 pixel 2.83" color TFT display with LED back-light, all driven by a **HX8347D** controller.

The TFT display is capable of showing graphics in 262,144 different colors. It's connected to microcontroller PORTE by a standard 8080 parallel 8-bit interface, with additional control lines. The board features a back-light driver that can operate in a standard (full brightness) mode, or it can be driven with a PWM signal which allows you to regulate brightness levels from 0% to 100%.

IMPORTANT: *In order to use PWM back-light both **SW13.3** and **SW13.4** switches must be enabled at the same time.*

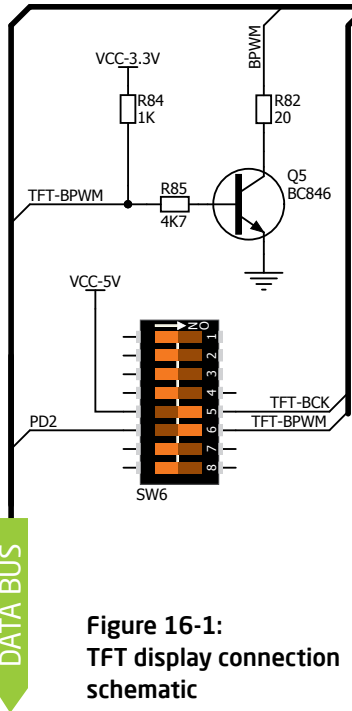
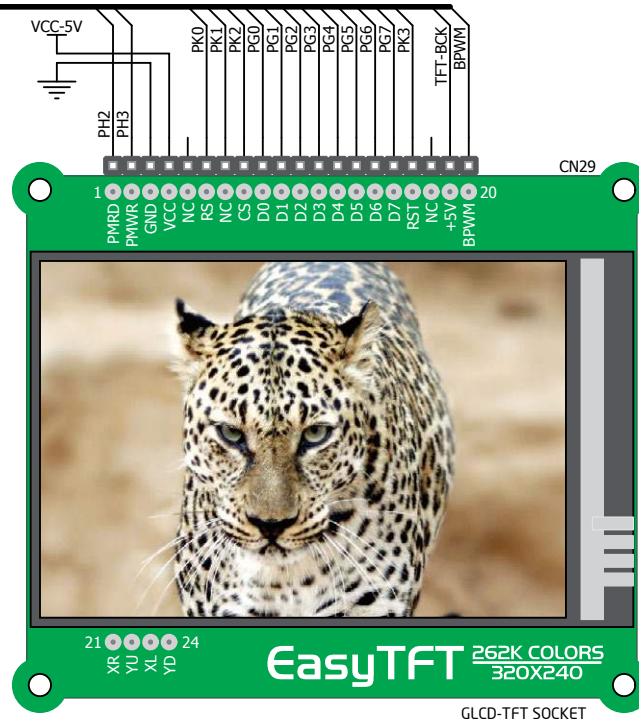

Figure 16-1:
TFT display connection
schematic



Driving display back-light

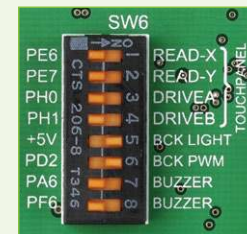

Figure 16-2: Turn on switches **SW6.5** and **SW6.6** to enable back-light

To enable the TFT display, use **SW6.5-SW6.6** DIP switches. You can enable the Back-light in two different ways:

1. Turn it on with **full brightness** using **SW6.5** switch.
2. You can control the brightness levels **with PWM signal** from the microcontroller, allowing you to write custom back-light controlling software. This back-light mode is enabled when both **SW6.5** and **SW6.6** switches are in ON position.

Touch panel controller

A touch panel is a glass panel whose surface is covered with two layers of resistive material. When the screen is pressed, the outer layer is pushed onto the inner layer and appropriate controllers can measure that pressure and pinpoint its location. This is how touch panels can be used as input devices. EasyMx PRO™ v7 for Tiva™ C Series is equipped with

a touch panel controller and connector for **4-wire resistive touch panels**. It can very accurately register pressure at specific points, representing the touch coordinates in the form of analog voltages, which can then be easily converted to X and Y coordinates. Touch panel comes as a part of the EasyTFT 320x240 display board.

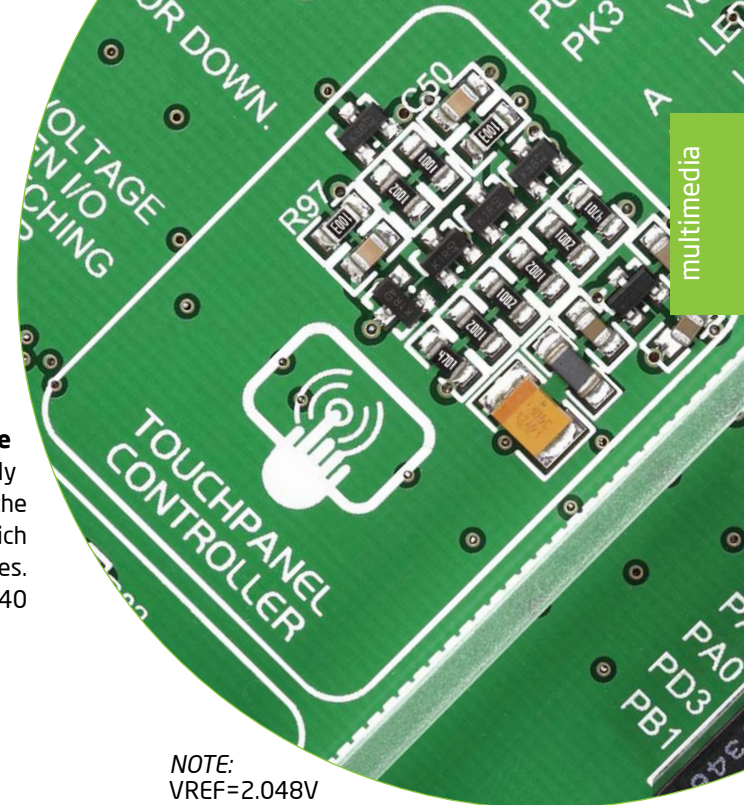

Enabling touch panel

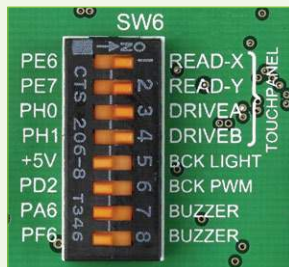
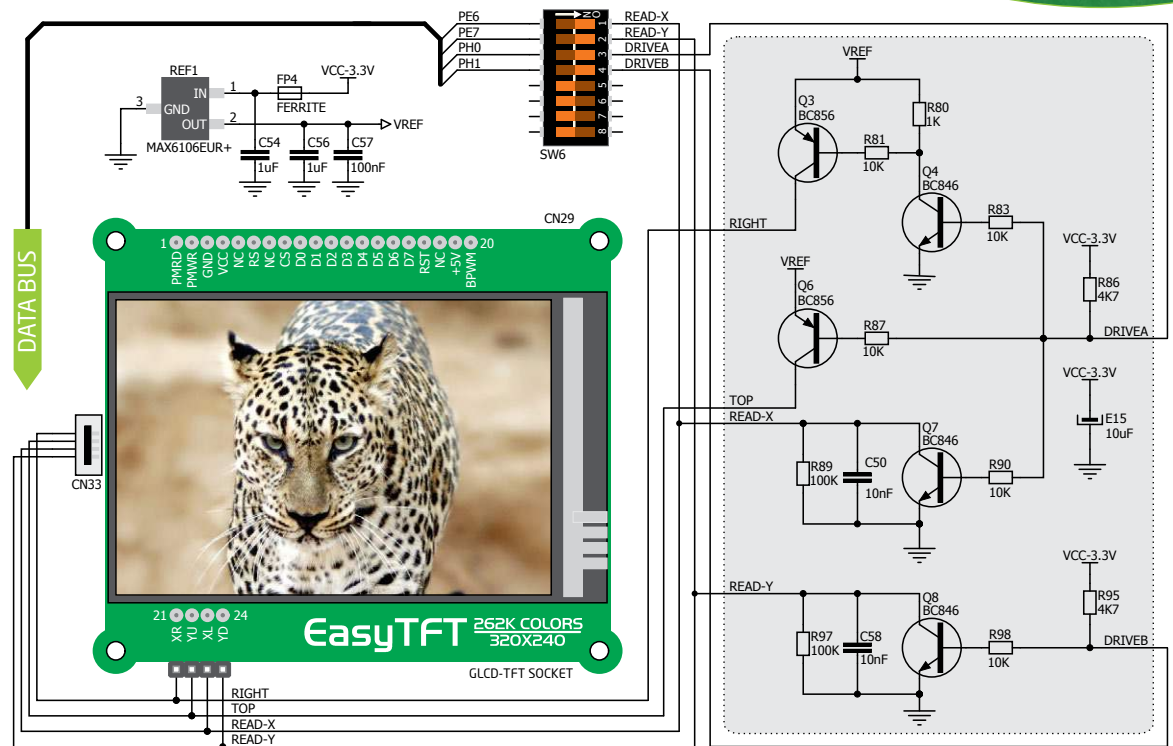
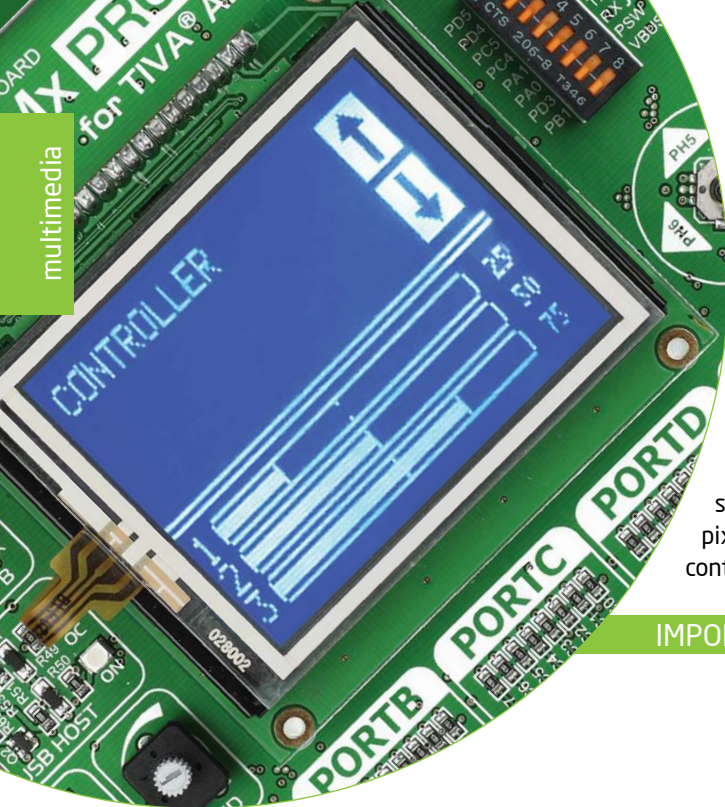

Figure 17-2: Turn on switches **SW6.1, SW6.2, SW6.3** and **SW6.4** to enable Touch panel controller

To enable the touch panel use **SW6.1, SW6.2, SW6.3** and **SW6.4** switches. They connect **BOTTOM** and **LEFT** lines of the touch panel with **PE6** and **PE7** analog inputs, and **DRIVEA** and **DRIVEB** with **PH0** and **PH1** digital outputs on microcontroller sockets. Make sure to disconnect other peripherals, LEDs and additional pull-up or pull-down resistors from the interface lines to avoid interferences with signal/data integrity.

Figure 17-1: Touch Panel controller and connection schematic





GLCD 128x64

Graphical Liquid Crystal Displays, or **GLCDs** are used to display monochromatic graphical content, such as text, images, human-machine interfaces and other content. EasyMx PRO™ v7 for Tiva™ C Series provides the connector and necessary interface for supporting GLCD with resolutions of 128x64 pixels, driven by the KS108 or compatible display controllers. Communication with the display module

is done through a **CN29** display connector. The board is fitted with a uniquely designed plastic display distancer that allows the GLCD module to perfectly and firmly fit into place. The Display connector is routed to PORTE (control and data lines) of the microcontroller sockets. PORTE is also used by the TFT display. You can control the display's contrast using the dedicated potentiometer **P2**. Full brightness display back-light can be enabled with **SW6.5** switch, and PWM-driven back-light with **SW6.6** switch.

IMPORTANT: *In order to use PWM back-light both **SW6.5** and **SW6.6** switches must be enabled at the same time.*



Connector pinout explained

- CS1** and **CS2** - Controller Chip Select lines
- VCC** - +5V display power supply
- GND** - Reference ground
- Vo** - GLCD contrast level from potentiometer P3
- RS** - Data (High), Instruction (Low) selection line
- R/W** - Determines whether display is in Read or Write mode.
- E** - Display Enable line
- D0-D7** - Data lines
- RST** - Display reset line
- Vee** - Reference voltage for GLCD contrast potentiometer P3
- LED+** - Connection with the back light LED anode
- LED-** - Connection with the back light LED cathode

Figure 18-1: GLCD 128x64 connection schematic

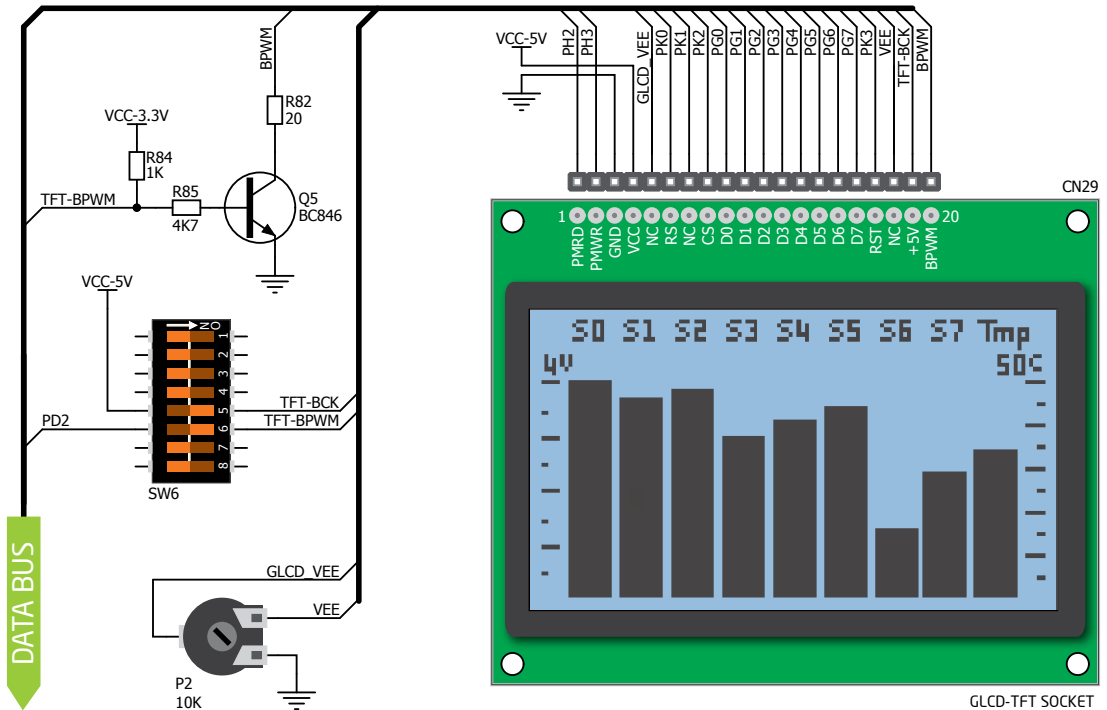

Navigation switch



Figure 19-2: Navigation switch is an intuitive solution for browsing through on-screen menus.

When working with multimedia applications it is far more intuitive to use a single joystick than several different push buttons that are more far apart. This is more natural for users and they can browse through on-screen menus, or even play games much easier. EasyMx PRO™ v7 for Tiva™ C Series features a navigation switch with five different positions: **Up, Down, Left, Right** and **Center**. Each of those acts as a button, and are connected to one of the following microcontroller pins: **PH5, PH4, PH6, PH7, PJ2** (respectively). Before using the navigation switch, it is necessary to pull-up the specified pins using tri-state DIP switches located in I/O groups. After pressing the navigation switch in the desired direction, associated microcontroller pins are connected to GND.

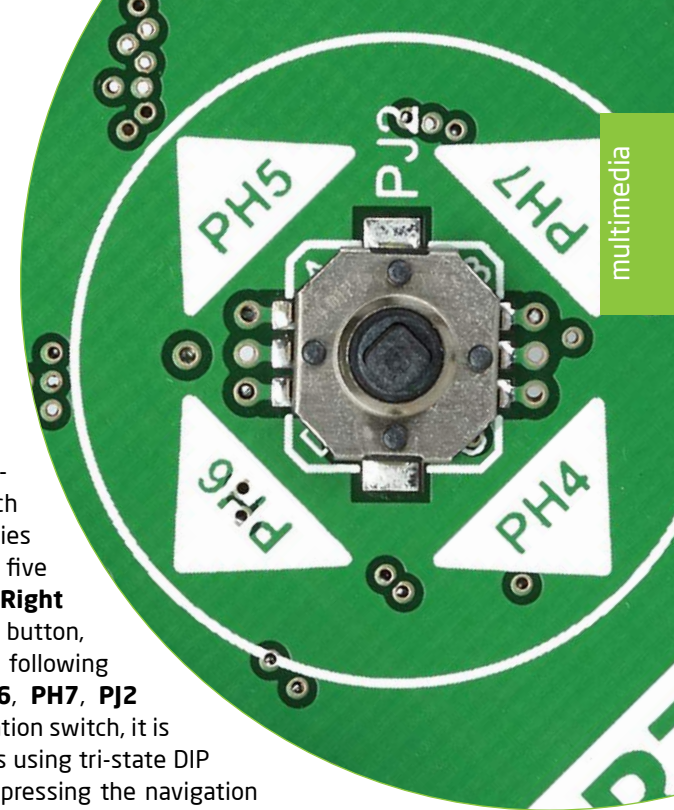

multimedia

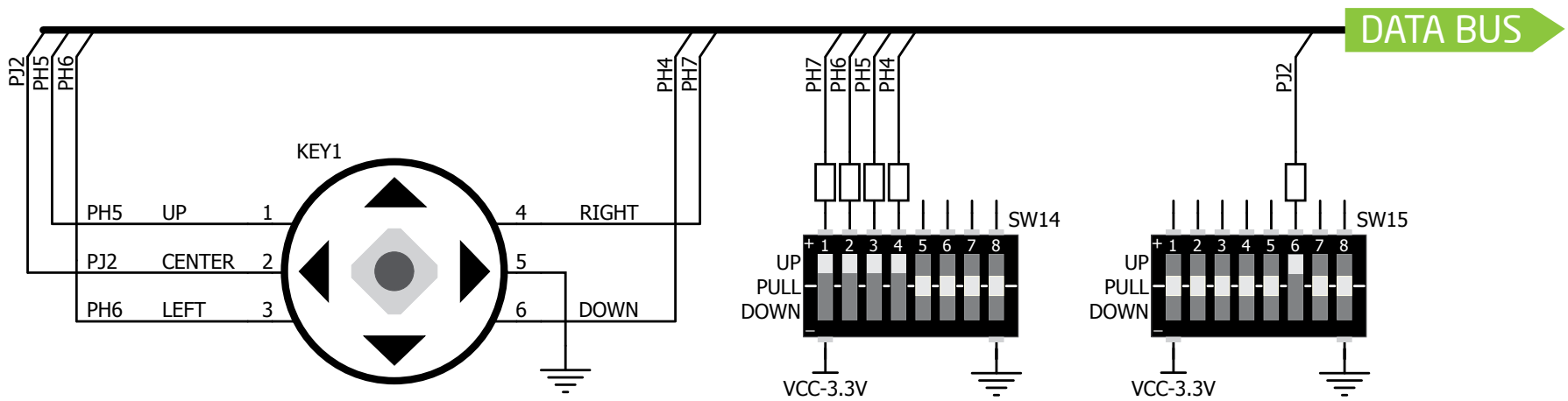
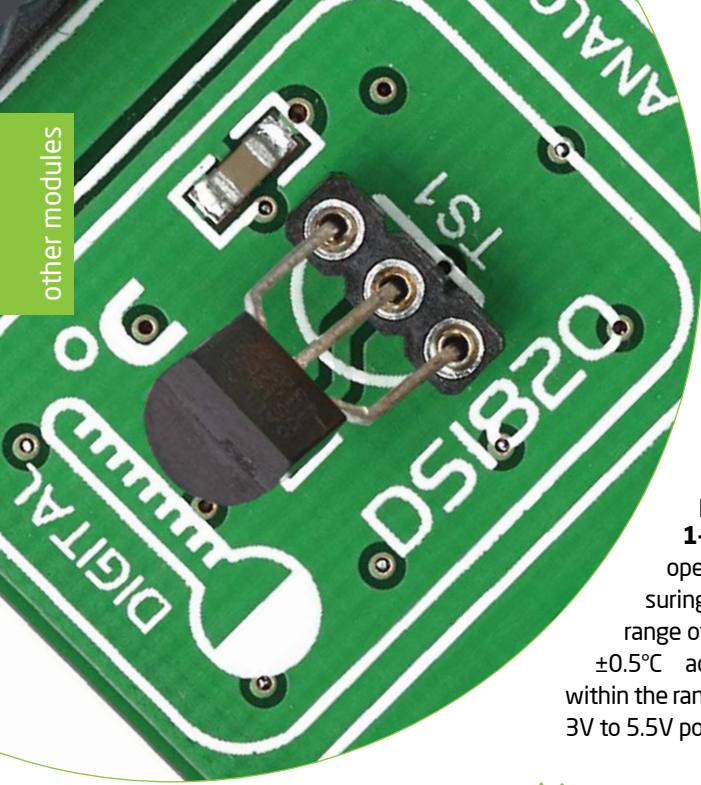

Figure 19-1: Navigation switch connection schematic. Pull-up resistors should be enabled during operation.



DS1820 - Digital temperature sensor

DS1820 is a digital temperature sensor that uses **1-wire® interface** for its operation. It is capable of measuring temperatures within the range of -55 to 128°C, and provides ±0.5°C accuracy for temperatures within the range of -10 to 85°C. It requires 3V to 5.5V power supply for stable operation.

It takes maximum of 750ms for the DS1820 to calculate temperature with 9-bit resolution. **1-wire® serial communications** enable data to be transferred over a single communication line, while the process itself is under the control of the master microcontroller. The advantage of this communications interface is that only one microcontroller pin is used.

Multiple sensors can be connected on the same line. All slave devices by default have a unique ID code, which enables the master device to easily identify all devices sharing the same interface. Board provides a separate socket (**TS1**) for the DS1820. Communication line with the microcontroller is established using **SW11.5** or **SW11.6** DIP switch (ON position).



Enabling DS1820 sensor

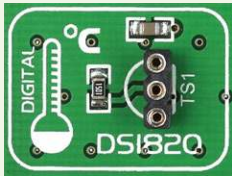

Figure 20-1: DS1820 socket



Figure 20-2: DS1820 correctly placed in socket

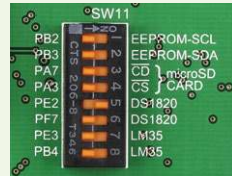

Figure 20-3: Enabled SW11.5 DIP switch

EasyMx PRO™ v7 for Tiva™ C Series enable you to establish 1-wire® communication between **DS1820** and the microcontroller over **PE2** or **PF7** pin. The connection is done placing **SW11.5** or **SW11.6** DIP switch to ON position (**Figure 20-3**). When placing the sensor in the socket make sure that the half-circle on the board's silkscreen markings matches the rounded part of the DS1820 sensor. If you accidentally connect the sensor the other way, it may be permanently damaged. Make sure to disconnect other peripherals, LEDs and additional pull-up or pull-down resistors from the interface lines to avoid interfering with signal/data integrity.

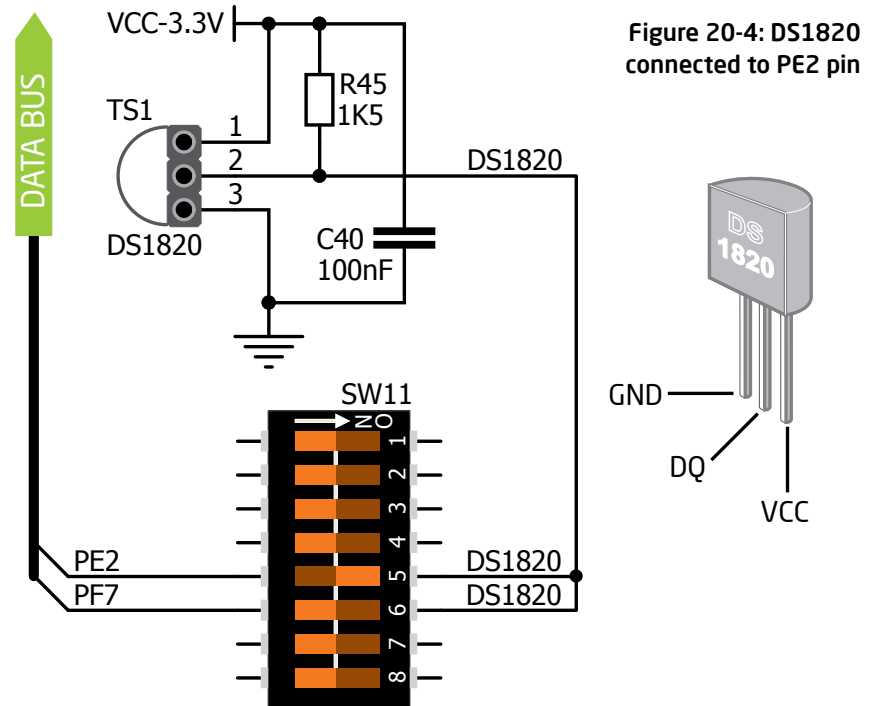

Figure 20-4: DS1820 connected to PE2 pin

LM35 - Analog temperature sensor

The **LM35** is a low-cost precision integrated-circuit temperature sensor, whose output voltage is linearly proportional to the Celsius (Centigrade) temperature. The LM35 thus has an advantage over linear temperature sensors calibrated in degrees Kelvin, as the user is not required to subtract a large constant voltage from its output to obtain convenient

Centigrade scaling. It has a linear $+10.0$ mV/ $^{\circ}\text{C}$ scale factor and less than $60 \mu\text{A}$ current drain. As it draws only $60 \mu\text{A}$ from its supply, it has very low self-heating, less than 0.1°C in still air. EasyMx PRO[™] v7 for Tiva[™] C Series enables you to get analog readings from the LM35 sensor in restricted temperature range from $+2^{\circ}\text{C}$ to $+150^{\circ}\text{C}$. Board provides a separate

socket (**TS2**) for the LM35 sensor in TO-92 plastic packaging. The microcontroller reads off the temperature data from a single analog input line, which is selected with DIP switch **SW11.7** or **SW11.8**. The Switches connects the sensor with **PE3** or **PB4** microcontroller pins.

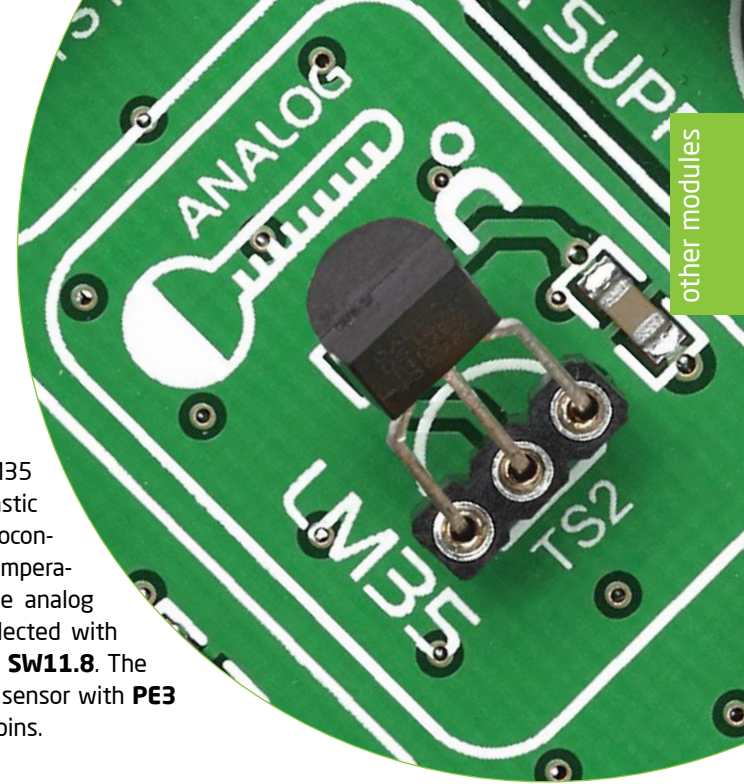

Enabling LM35 sensor

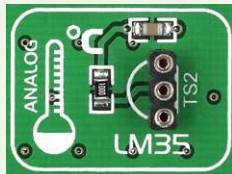

Figure 21-1:
LM35 socket



Figure 21-2:
LM35 correctly placed in socket

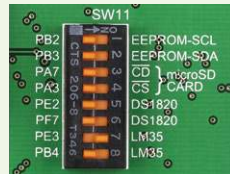
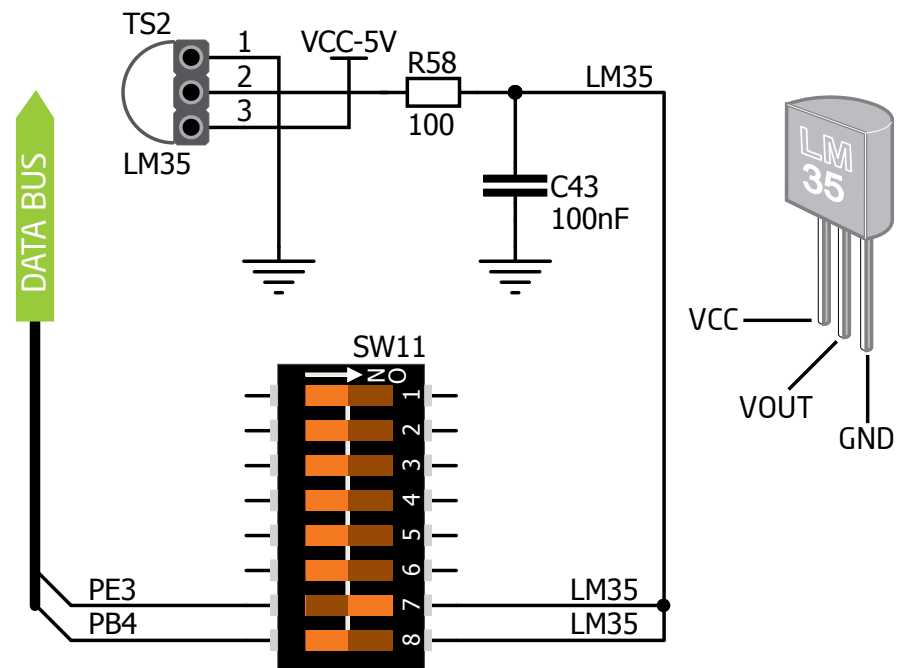

Figure 21-3:
Enabled SW14.7 DIP switch

EasyMx PRO[™] v7 for Tiva[™] C Series enables you to get analog readings from the LM35 sensor using **PE3** or **PB4** microcontroller pins. The connection is done placing **SW11.7** or **SW11.8** DIP switch to ON position (**Figure 21-4**). When placing the sensor in the socket make sure that the half-circle on the board's silkscreen markings matches the rounded part of the LM35 sensor. If you accidentally connect the sensor the other way, it can be permanently damaged and you might need to replace it with another one. During the readings of the sensor, make sure that no other device uses the selected analog line, because it may interfere with the readings.

Figure 21-4: LM35 connected to PE3 pin



Serial flash memory

Flash memory is a non-volatile storage chip that can be electrically erased and reprogrammed. It was developed from EEPROM (electrically erasable programmable read-only memory) and must be erased in fairly large blocks before these can be rewritten with new data. There are two types of Flash memory: NAND and NOR. The high density NAND type must be programmed and read in (smaller) blocks, or pages, while the NOR type allows a single machine word (byte) to be written or read independently. Flash memories come in different sizes and support different clock speeds. They are mostly used for mass storage, as in USB Flash Drives, which are very popular today.

EasyMx PRO™ v7 Tiva™ C Series features **M25P80** Serial Flash Memory which uses **SPI communication interface** and has **8 Mbits** of available memory, organized as 16 sectors, each containing 256 pages. Each page is 256 bytes wide. Thus, the whole memory can be viewed as consisting of 4096 pages, or 1,048,576 bytes. Maximum clock frequency for READ instructions is 40MHz.

What is SPI?

The **Serial Peripheral Interface Bus** or SPI bus is a synchronous serial data link standard that operates in full duplex mode. It consists of four lines **MISO** (Master Input Slave Output), **MOSI** (Master Output Slave Input), **SCK** (Clock) and **CS** (Chip Select). Devices communicate in master/slave mode where the master device initiates the data frame. Multiple slave devices are allowed with individual slave select (chip select) lines.



Enabling serial flash

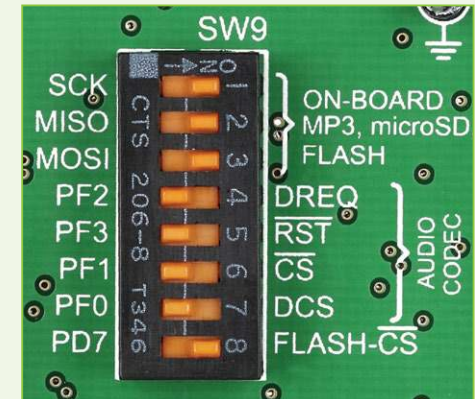

In order to connect Serial Flash Memory to the microcontroller you must enable **SW9.1, SW9.2, SW9.3** and **SW9.7** switches. This connects SPI lines to **MCU_MOSI, MCU_MISO, MCU_SCK** and **PD7** (CS) microcontroller pins.

Figure 22-1: Serial Flash Memory module schematic

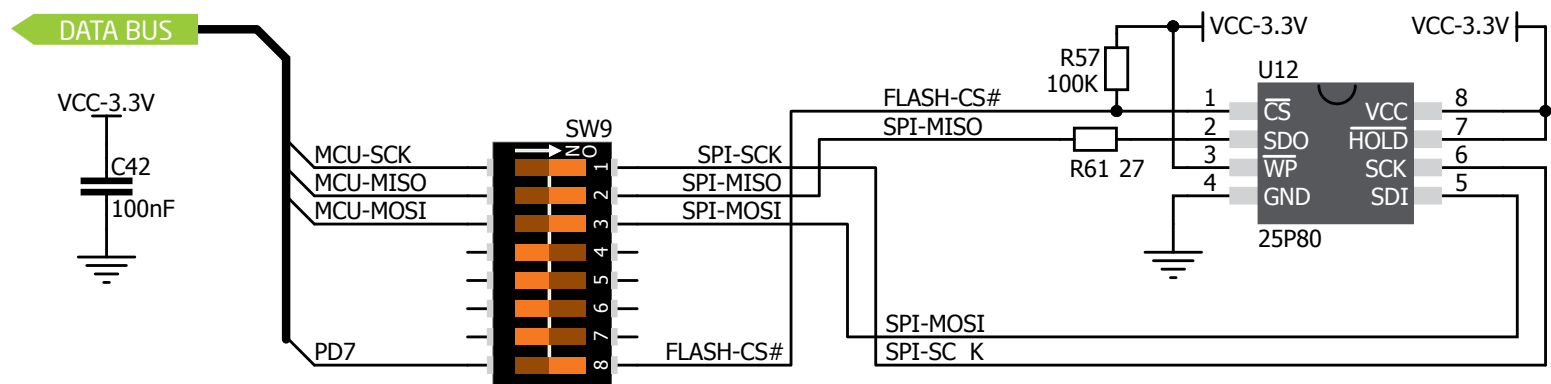

I²C EEPROM



Enabling I²C EEPROM

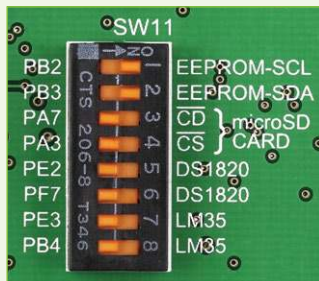

Figure 23-2: Turn on switches **SW11.1** and **SW11.2** to connect EEPROM lines to MCU

In order to connect I²C EEPROM to the microcontroller you must enable **SW11.1** and **SW11.2** switches, as shown on **Figure 23-2**. **2K2** pull-up resistors necessary for I²C communications are already provided on **SDA** and **SCL** lines once switches are turned on. Prior to using EEPROM in your application, make sure to disconnect other peripherals, LEDs and additional pull-up or pull-down resistors from the **PB2** and **PB3** communication lines that could interfere with the data signals and cause data corruption.

EEPROM is short for **Electrically Erasable Programmable Read Only Memory**. It is usually a secondary storage memory in devices containing data that is retained even if the device loses its power supply. Because of the ability to alter single bytes of data, EEPROM devices are used to store personal preference and configuration data in a wide spectrum of consumer, automotive, telecommunication, medical, industrial, and PC applications.

EasyMx PRO™ v7 for Tiva™ C Series supports serial EEPROM that uses **I²C communication interface** and has **1024 bytes** of available memory. EEPROM itself supports single byte or 16-byte (page) write and read operations. Data rates are dependent of power supply voltage, and go up to **400 kHz** for 3.3V power supply.

What is I²C?

I²C is a multi-master serial single-ended bus that is used to attach low-speed peripherals to computer or embedded systems. I²C uses only two open-drain lines, **Serial Data Line (SDA)** and **Serial Clock line (SCL)**, pulled up with resistors. **SCL** line is driven by a master, while **SDA** is used as a bidirectional line either by a master or a slave device. Up to 112 slave devices can be connected to the same bus. Each slave must have a unique address.

Figure 23-1: I²C EEPROM module schematic

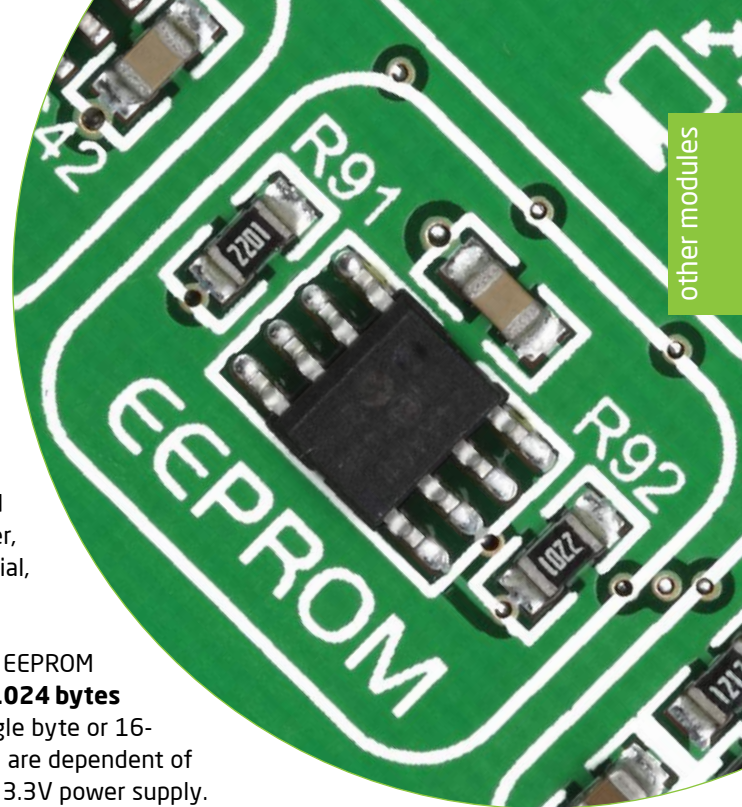
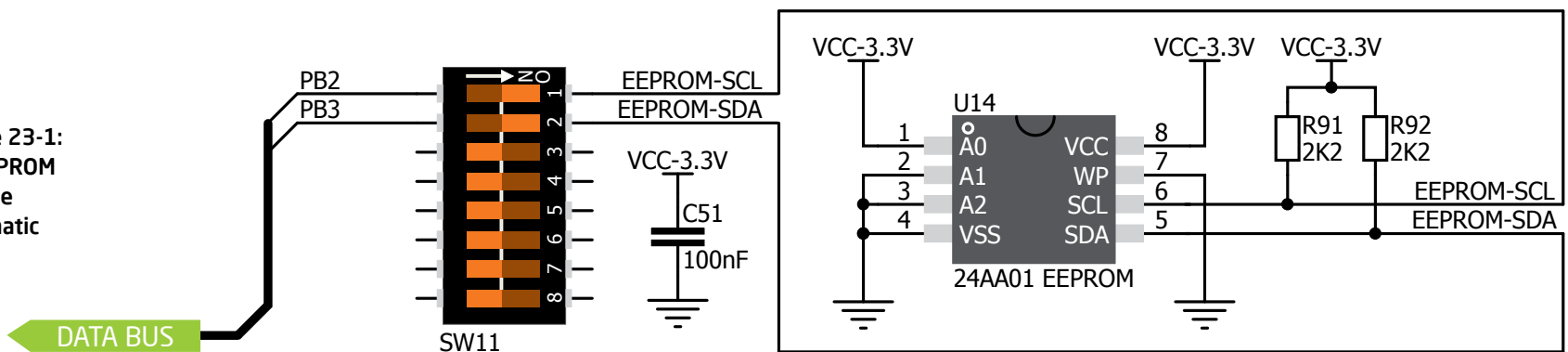

ADC inputs

Digital signals have **two discrete states**, which are decoded as **high** and **low**, and interpreted as **logic 1** and **logic 0**. **Analog signals**, on the other hand, are **continuous**, and can have any value within a defined range. **A/D converters** are specialized circuits that can convert analog signals (voltages) into a digital representation, usually in the form of an **integer number**. The value of this number is **linearly dependent** on the input voltage value. Most microcontrollers nowadays internally have A/D converters connected to one or more input pins. Some of the most important parameters of A/D converters are **conversion time** and **resolution**. Conversion time determines how fast can an analog voltage be represented in the form of a digital number. This is an important parameter if you need fast data acquisition. The other parameter is resolution. Resolution represents the number of discrete steps that the supported voltage range can be divided into. It determines the sensitivity of the

A/D converter. Resolution is represented in maximum number of bits that the resulting number occupies. Most microcontrollers have a 10-bit resolution, meaning that the maximum value of conversion can be represented with 10 bits, which converted to integer is $2^{10}=1024$. This means that the supported voltage range, for example from 0-1.8V, can be divided into 1024 discrete steps of about 1.758mV. EasyMx PRO™ v7 for Tiva™ C Series provides an interface in the form of a potentiometer for simulating analog input voltages that can be routed to any of the 5 supported analog input pins.



Enabling ADC inputs

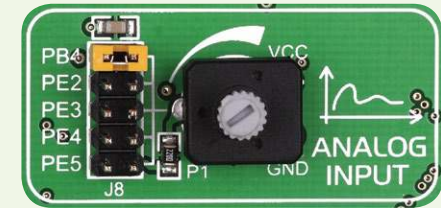

In order to connect the output of the potentiometer **P1** to **PB4**, **PE2**, **PE3**, **PE4** or **PE5** analog microcontroller inputs, you have to place the jumper **J8** in the desired position. By moving the potentiometer knob, you can create voltages in range from **GND** to **VCC**.

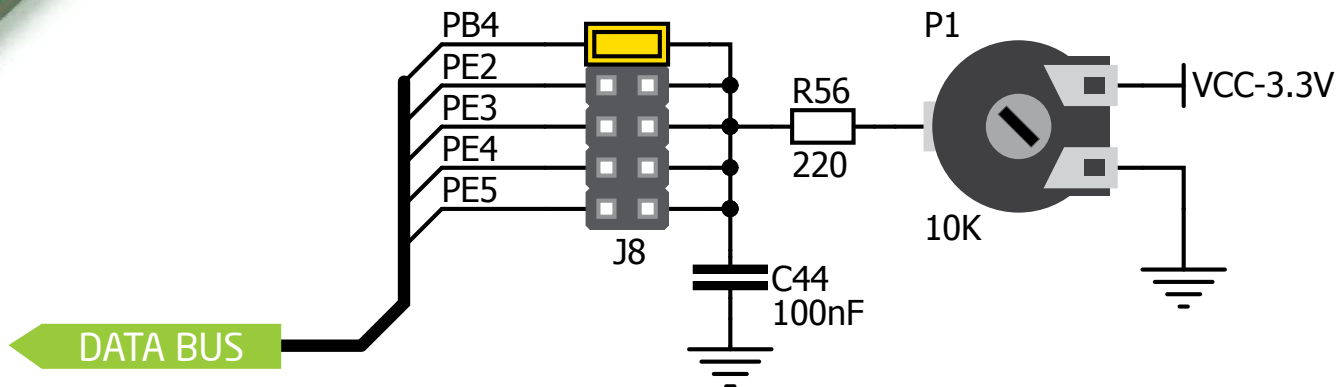

Figure 24-1:
ADC input
schematic

Piezo buzzer

Piezoelectricity is the charge that accumulates in certain solid materials in response to mechanical pressure. It works in reverse too: providing a charge to piezoelectric materials causes them to physically deform. One of the most widely used applications of piezoelectricity is the production of sound generators, called piezo buzzers. **Piezo buzzer** is an electric component that comes in different shapes and sizes, which can be used to create sound waves when provided with analog electrical signal. EasyMx PRO™ v7 for Tiva™ C Series comes with piezo buzzer which can be connected to **PA6** or **PF6** microcontroller pin. Connection is established using **SW6.7** or **SW6.8** DIP switch. Buzzer is driven by transistor **Q1** (Figure 25-1). Microcontrollers can create sound by generating a PWM (Pulse Width Modulated) signal – a **square wave** signal, which is nothing more than a sequence of logic zeros and ones. Frequency of the square signal determines

the pitch of the generated sound, and duty cycle of the signal can be used to increase or decrease the volume in the range from 0% to 100% of the duty cycle. You can generate PWM signal using hardware capture-compare module, which is usually available in most microcontrollers, or by writing a custom software which emulates the desired signal waveform.

Supported sound frequencies

Piezo buzzer's resonant frequency (where you can expect it's best performance) is **3.8kHz**, but you can also use it to create sound in the range between **2kHz** and **4kHz**.

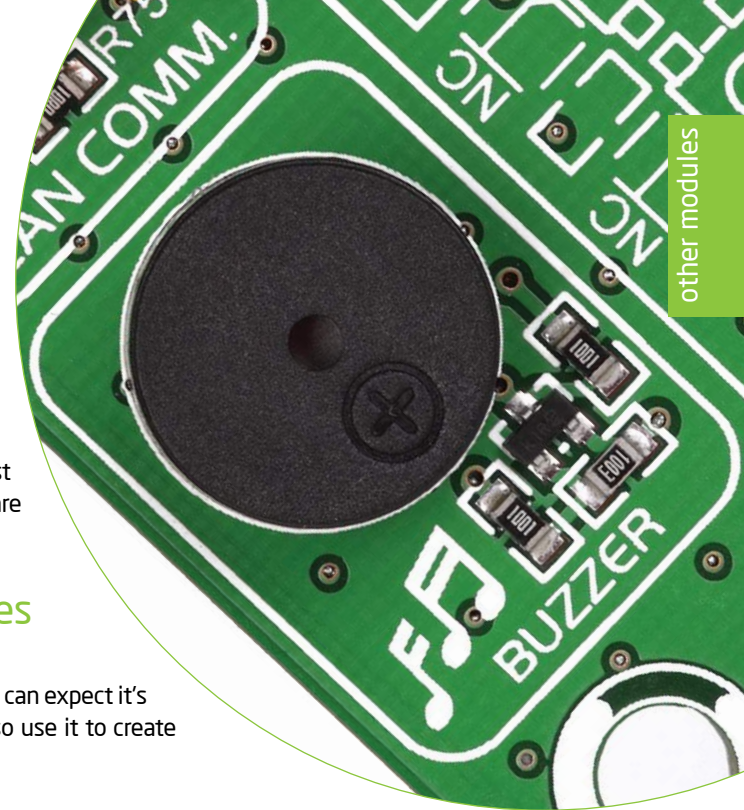

other modules

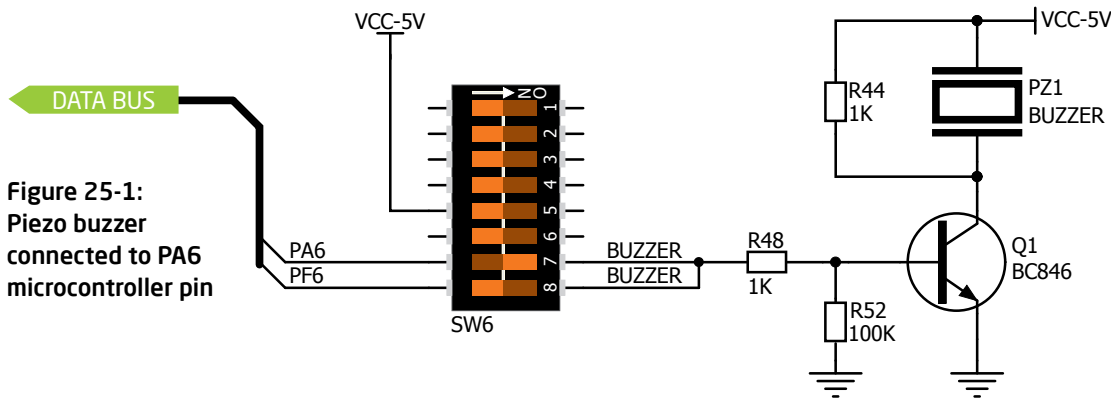

Figure 25-1: Piezo buzzer connected to PA6 microcontroller pin

Freq = 3kHz, Duty Cycle = 50%



Freq = 3kHz,
Volume = 50%

Freq = 3kHz, Duty Cycle = 80%



Freq = 3kHz,
Volume = 80%

Freq = 3kHz, Duty Cycle = 20%



Freq = 3kHz,
Volume = 20%

How to make it sing?

Buzzer starts "singing" when you provide PWM signal from the microcontroller to the buzzer driver. The pitch of the sound is determined by the frequency, and amplitude is determined by the duty cycle of the PWM signal.



Enabling piezo buzzer

In order to use the on-board Piezo Buzzer in your application, you first have to connect the transistor driver of piezo buzzer to the appropriate microcontroller pin. This is done using **SW6.7** or **SW6.8** DIP switch which connects it to **PA6** or **PF6** pin.

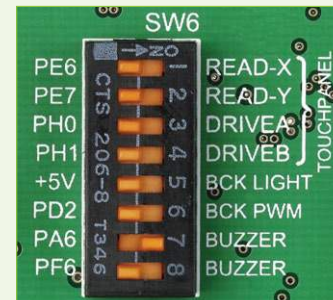

Figure 25-2: push SW6.7 to ON position to connect Piezo buzzer to PA6

Additional GNDs

EasyMx PRO™ v7 for contains **GND pins** located in different sections of the board, which allow you to easily connect an oscilloscope GND reference when you monitor signals on microcontroller pins, or signals of on-board modules.

- 1 GND is located below power supply region.
- 2 GND is located below microSD section.
- 3 GND is located just above PORTJ/K Input/Output Group.

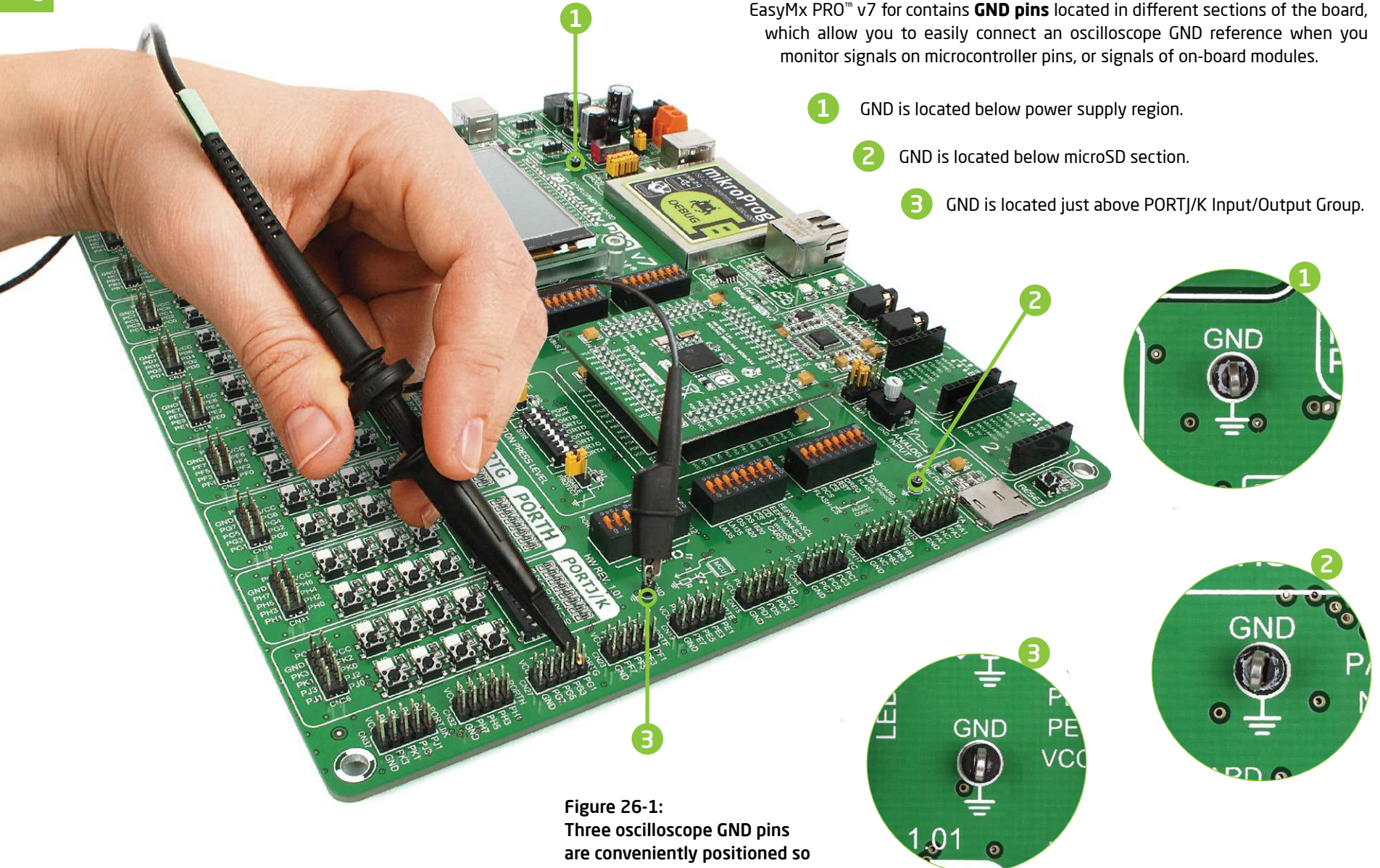

Figure 26-1:
Three oscilloscope GND pins are conveniently positioned so different parts of the board can be reached with an oscilloscope probe

What's next?

You have now completed the journey through each and every feature of **EasyMx PRO™ v7 for Tiva™ C Series** board. You got to know its modules, organization, supported microcontrollers, programmer and debugger. Now you are ready to start using your new board. We are suggesting several steps which are probably the best way to begin. We invite you to join the users of EasyMx PRO™ brand. You will find very useful projects and tutorials and can get help from a large ecosystem of users. Welcome!

1 Compiler

You still don't have an appropriate compiler? Locate **ARM® compiler** that suits you best on our website:



<http://www.mikroe.com/arm/compilers/>

Choose between **mikroC™**, **mikroBasic™** and **mikroPascal™** and download fully functional demo version, so you can begin building your ARM® Cortex™-M3 and Cortex™-M4 applications.



2 Projects

Once you have chosen your compiler, and since you already got the board, you are ready to start writing your first projects. We have equipped our compilers with dozens of examples that demonstrate the use of each and every feature of the **EasyMx PRO™ v7 for Tiva™ C Series** board, and all of our accessory boards as well. This makes an excellent starting point for your future projects. Just load the example, read the well commented code, and see how it works on hardware. Browse through the compiler **Examples** on this link:



<http://www.mikroe.com/easymx-pro/tiva/>

3 Community

If you want to find answers to your questions on many interesting topics we invite you to visit our forum at <http://www.mikroe.com/forum> and browse through more than 150 thousand posts. You are likely to find just the right information for you. On the other hand, if you want to download free projects and libraries or share your own code, please visit the **Libstock website**. With user profiles, you can get to know other programmers, and subscribe to receive notifications on their code.



<http://www.libstock.com/>

4 Support

We all know how important it is that we can rely on someone in moments when we are stuck with our projects, facing a deadline, or when we just want to ask a simple, basic question, that's pulling us back for a while. We do understand how important this is to people and therefore our Support Department is one of the pillars upon which our company is based. MikroElektronika offers **Free Tech Support** to the end of product lifetime, so if something goes wrong, we are ready and willing to help!



<http://www.mikroe.com/support/>

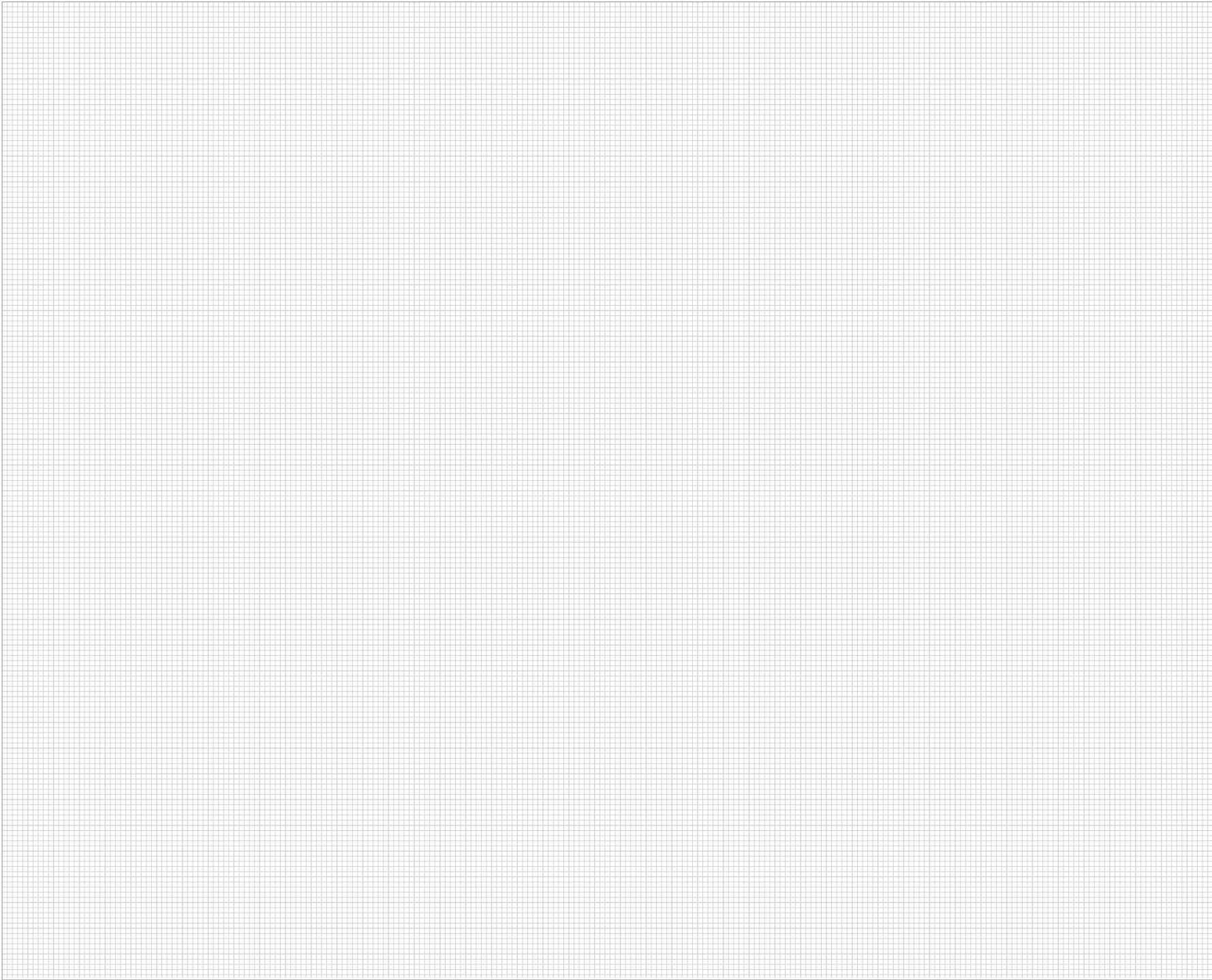

DISCLAIMER

All the products owned by MikroElektronika are protected by copyright law and international copyright treaty. Therefore, this manual is to be treated as any other copyright material. No part of this manual, including product and software described herein, must be reproduced, stored in a retrieval system, translated or transmitted in any form or by any means, without the prior written permission of MikroElektronika. The manual PDF edition can be printed for private or local use, but not for distribution. Any modification of this manual is prohibited.

MikroElektronika provides this manual 'as is' without warranty of any kind, either expressed or implied, including, but not limited to, the implied warranties or conditions of merchantability or fitness for a particular purpose.

MikroElektronika shall assume no responsibility or liability for any errors, omissions and inaccuracies that may appear in this manual. In no event shall MikroElektronika, its directors, officers, employees or distributors be liable for any indirect, specific, incidental or consequential damages (including damages for loss of business profits and business information, business interruption or any other pecuniary loss) arising out of the use of this manual or product, even if MikroElektronika has been advised of the possibility of such damages. MikroElektronika reserves the right to change information contained in this manual at any time without prior notice, if necessary.

HIGH RISK ACTIVITIES

The products of MikroElektronika are not fault - tolerant nor designed, manufactured or intended for use or resale as on - line control equipment in hazardous environments requiring fail - safe performance, such as in the operation of nuclear facilities, aircraft navigation or communication systems, air traffic control, direct life support machines or weapons systems in which the failure of Software could lead directly to death, personal injury or severe physical or environmental damage ('High Risk Activities'). MikroElektronika and its suppliers specifically disclaim any expressed or implied warranty of fitness for High Risk Activities.

TRADEMARKS

The MikroElektronika name and logo, the MikroElektronika logo, mikroC™, mikroBasic™, mikroPascal™, mikroProg™, mikromedia™, EasyMx PRO™, mikroBUS™ and click boards™ are trademarks of MikroElektronika. All other trademarks mentioned herein are property of their respective companies.

All other product and corporate names appearing in this manual may or may not be registered trademarks or copyrights of their respective companies, and are only used for identification or explanation and to the owners' benefit, with no intent to infringe.

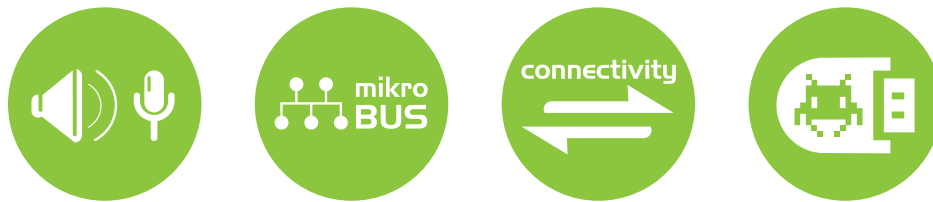

If you want to learn more about our products, please visit our website at www.mikroe.com

If you are experiencing some problems with any of our products or just need additional information, please place your ticket at www.mikroe.com/support

If you have any questions, comments or business proposals,
do not hesitate to contact us at office@mikroe.com