



TELEDYNE LECROY
Everywhereyoulook™



Operator's Manual

**AP015
Current Probe**

AP015 Current Probe
Operator's Manual

October 2013





700 Chestnut Ridge Road
Chestnut Ridge, NY, 10977-6499
Tel: (845) 425-2000
Fax: (845) 578 5985
teledynelecroy.com

© 2013 Teledyne LeCroy, Inc. All rights reserved.

Unauthorized duplication of Teledyne LeCroy documentation materials other than for internal sales and distribution purposes is strictly prohibited. However, clients are encouraged to distribute and duplicate Teledyne LeCroy documentation for their own internal educational purposes.

Teledyne LeCroy is a registered trademark of Teledyne LeCroy, Inc. Windows is a registered trademark of Microsoft Corporation. Other product or brand names are trademarks or requested trademarks of their respective holders. Information in this publication supersedes all earlier versions. Specifications are subject to change without notice.

Warranty

Teledyne LeCroy warrants this oscilloscope accessory for normal use and operation within specification for a period of one year from the date of shipment. Spare parts, replacement parts and repairs are warranted for 90 days.

In exercising its warranty, Teledyne LeCroy, at its option, will either repair or replace any assembly returned within its warranty period to the Customer Service Department or an authorized service center. However, this will be done only if the product is determined by Teledyne LeCroy's examination to be defective due to workmanship or materials, and the defect is not caused by misuse, neglect, accident, abnormal conditions of operation, or damage resulting from attempted repair or modifications by a non-authorized service facility.

The customer will be responsible for the transportation and insurance charges for the return of products to the service facility. Teledyne LeCroy will return all products under warranty with transportation charges prepaid.

This warranty replaces all other warranties, expressed or implied, including but not limited to any implied warranty of merchantability, fitness or adequacy for any particular purposes or use. Teledyne LeCroy shall not be liable for any special, incidental, or consequential damages, whether in contract or otherwise.

922254-00 Rev A
October 2013

Safety Instructions

This section contains instructions that must be observed to keep this oscilloscope accessory operating in a correct and safe condition. You are required to follow generally accepted safety procedures in addition to the precautions specified in this section. **The overall safety of any system incorporating this accessory is the responsibility of the assembler of the system.**

Symbols

These symbols may appear on the probe body or in this manual to alert you to important safety considerations.



WARNING. High Voltage, risk of electric shock.



CAUTION. Potential for damage to probe or instrument it is connected to. Attend to the accompanying information to protect against personal injury or damage. Do not proceed until conditions are fully understood and met.



ELECTROSTATIC DISCHARGE (ESD) HAZARD. The probe is susceptible to damage if anti-static measures are not taken.



DOUBLE INSULATION



PROTECTIVE (EARTH) TERMINAL

Precautions

To avoid personal injury or damage to property, review and comply with the following safety precautions.

Use product only as specified. Use of the probe is restricted to insulated conductors or limited energy circuit conductors.

Connect and disconnect properly. Connect probe to the measurement instrument before making any connections to a voltage/current source.

ADP015 Current Probe

Observe all terminal ratings. To avoid electric shock or fire, do not use the probe above the current & voltage limits shown on the probe as well as all accessories.

Do not remove probe casing. Removing the probe's case or touching exposed connections may result in electric shock.

Use indoors only.

Use only within operational environment listed. Do not use in wet or explosive atmospheres.

Keep product surfaces clean and dry. Clean with a cloth moistened in water or alcohol. Do not submerge instrument. Do not use harsh or abrasive cleansers.

Do not operate with suspected failures. Do not use the probe if any part is damaged. Cease operation immediately and sequester the probe from inadvertent use.



WARNING. To avoid risk of electric shock, keep your fingers behind the finger guard when locking and unlocking the probe slider. Keep the probe cable away from the circuits being measured. Use only the specified accessories.



WARNING. The probe is classified as a Type D current sensor per EN61010-032 safety standard. Use of the probe is restricted to insulated conductors or limited energy circuit conductors. Any use of the probe in a manner not specified by the manufacturer may impair the probe's safety protection.

Operating Environment

The accessory is intended for indoor use and should be operated in a clean, dry environment. Before using this product, ensure that its operating environment is maintained within these parameters:

Temperature: 0 to 40 °C

Humidity: 80% maximum up to 31 °C

Altitude: 2000 m maximum

Specifications

The following specifications are valid for model AP015 current probes after the probe has reached operating temperature, which is 20 minutes with power applied in a environment with stable ambient temperature. The probe must be operating within the environmental conditions listed in the General Characteristics section, and has been calibrated within the past 12 months in an ambient temperature of 23 ± 5 °C.

Nominal Characteristics

Nominal characteristics describe parameters and attributes which are guaranteed by design, but do not have associated tolerances.



| | |
|--------------------------------------|---|
| Interface: | ProBus |
| Coupling: | AC, GND, DC |
| Maximum Current: | DC ± 30 A (continuous) ± 50 A maximum (< 10 s) |
| Sensitivity: | 10 mA/div to 20 A/div |
| Offset Range: | ± 100 A maximum |
| Maximum Conductor Size: | 5 mm |
| Maximum Voltage (bare conductor): | 300 V CAT I 150 V CAT II |
| Cable Length: | 2 m |
| Weight (probe only): | 300 g (10.6 oz.) |

Warranted Electrical Characteristics

Warranted characteristics describe parameters which have guaranteed performance. Unless otherwise noted, tests are provided in the Performance Verification Procedure for all warranted specifications.

| | |
|--------------|---|
| DC Accuracy: | $\pm 1\%$ of reading to 15 A (at 25 °C, after degauss) |
| | $\pm 2\%$ of reading to 30 A (at 25 °C, after degauss) |
| Bandwidth: | DC to 50 MHz |

Typical Electrical Characteristics

Typical characteristics describe parameters which do not have guaranteed performance, however are representative of the average performance from a sample of several probes. Tests for typical characteristics are not provided in the Performance Verification Procedure.

| | |
|----------------------|---|
| Rise Time: | < 7 ns |
| Slew Rate: | > 1.6 A/ns (sensitivity \geq 1 A/div) |
| Insertion Impedance: | < 0.06 Ω at 5 MHz |

Performance Verification

This procedure can be used to verify the warranted characteristics of the AP015 Current Probe.

The recommended calibration interval for the model AP015 Current Probe is one year. The complete performance verification procedure should be performed as the first step of annual calibration. Performance verification can be completed without removing the instrument covers or exposing the user to hazardous voltages. Test results can be recorded on a photocopy of the Test Record provided at the end of this manual.

Adjustment should only be attempted if a parameter measured in the Performance Verification Procedure is outside of the specification limits. Adjustment should only be performed by qualified personnel.

Required Equipment

The following table lists the test equipment and accessories, or their equivalents, that are required for performance verification of the AP015 Current Probe. Because the input and output connector types may vary on different brands and models of test instruments, additional adapters or cables may be required.

Table 1. List of Required Equipment

| Description | Minimum Requirements | Test Equipment Examples |
|---------------------------------------|---|---|
| Wide Band oscilloscope | Minimum 200 MHz bandwidth ProBus interface equipped Software Version 7.6.0 or greater | Teledyne LeCroy LT322 Teledyne LeCroy X-Stream scope with AP-1M Hi-Z adapter |
| Digital Multimeter (2 required) | DC: 0.1% accuracy 5.5 digit resolution with Null capability (referenced measurements) | Agilent Technologies 34401A Fluke 8842A-09 Keithley 2001 |
| Leveled Sine Wave Generator | Relative output level accurate to ± 0.3 dB into 50 Ω 1 to 100 MHz frequency range Output adjustable to 18 dBm | Tegam SG503 with TM series mainframe and matching output cable. A semiautomatic software leveled signal source calibrated with a power meter may be substituted. |
| DC Power Supply | Output adjustable to > 6 V at 1 A | Agilent Technologies E3610A |
| Calibration Fixture, 50 Turn Loop | 50 Turn loop in series with 0.5 $\Omega \pm 0.2\%$ resistor with sense terminals | Teledyne LeCroy CP015-CF02 |
| Calibration Fixture, High Speed Shunt | 50 Ω Termination into single turn loop. VSWR < 1.25: 1 DC – 50 MHz | Teledyne LeCroy CP015-CF01 |
| Calibration Fixture | ProBus Extension Cable | Teledyne LeCroy PROBUS-CF01 |
| BNC Adapter, T | Male-to-Dual-Female | Pomona 3285 |
| BNC coaxial cable | Male-Male BNC, 50 Ω , 36" | Pomona 5697-36 |
| Banana Plug adapter | BNC Female-to-Banana Plug | Pomona 1269 |
| Patch Cables (4 required) | Male Banana-to-Male Banana, 12" | Pomona B-12-0 (black) Pomona B-12-2 (red) |

Preliminary Procedure

1. Connect the AP015 to the channel 1 input of the oscilloscope, and completely close the probe slider.
2. Turn the oscilloscope on and allow at least 30 minutes warm-up time for the AP015 and test equipment before performing the Verification Procedure.
3. Turn on the other test equipment and allow these to warm up for the time recommended by the manufacturer.
4. While the instruments are reaching operating temperature, make a photocopy of the Performance Verification Test Record (located at the back of this manual) and fill in the necessary data.

Functional Check

The functional check will verify the basic operation of all probe functions. It is recommend that the Functional Check be performed prior the Performance Verification Procedure.

1. For LT series scopes, select Channel 1, select the Coupling menu, and verify that Global BWL is set to OFF.
2. Verify that Probe sensed (AP015) is displayed.
3. Unlock the slider on the probe by pushing the lever towards the probe cable. Release the lever so that the input slider remains closed, but unlocked.
4. Verify that the message: Warning: AP015 Probe Unlocked... is displayed at the top of the screen.
5. Lock the probe slider by pushing fully away from the probe cable.
6. Verify that the warning message disappears.
7. Degauss the probe by pressing the DEGAUSS button, (located in the Coupling menu), twice.
8. Verify that no error message remains displayed at the top of the screen.

Performance Verification Procedure

The warranted characteristics of the AP015 Current Probe are valid at any temperature within the Environmental Characteristics listed in the Specifications. However, some of the other test equipment used to verify the performance may have environmental limitations required to meet the accuracy needed for the procedure. Make sure that the ambient conditions meet the requirements of all the test instruments used in this procedure.

NOTE: The correct operation of the controls of the AP015 requires oscilloscope software version 7.6.0 or higher for LT series scopes. The use of earlier versions is not recommended. The software version in the LT series test oscilloscope can be verified by pushing SHOW STATUS, then selecting the System menu option. Contact your local Teledyne LeCroy representative if the software in your oscilloscope requires updating.

A. Check Bandwidth

1. Set the Leveled Sine Wave Generator frequency to 50 kHz, the output level to approximately 5 Vp-p (+18 dBm), and turn RF ON.
2. Connect the output to the BNC connection of the high-speed shunt calibration fixture, AP015-CF02, using the matched BNC coaxial cable specified for use with the leveled sine wave generator.
3. Open the slider and connect the AP015 to the high-speed shunt calibration fixture. Close and lock the probe slider by pushing it fully away from the probe cable.
4. Push the AUTO SETUP button on the oscilloscope. Press MEASURE TOOLS, set the mode to Std Voltage, on trace 1, from 0.00 div to 10.00 div.
5. Adjust the generator level until the current is 100 mA peak-to-peak, as measured using the peak-to-peak function on the oscilloscope.
6. Set the sine wave generator frequency to 25 MHz. Be careful not to alter the signal amplitude.
7. Slowly increase the output frequency until the displayed amplitude of the current sine wave decreases to 71 mA peak-to-peak (a 3 dB reduction in amplitude).

ADP015 Current Probe

8. Check that this frequency is greater than 50 MHz, and record the frequency on the test record.

B. Check DC Accuracy

1. Set the DC Power Supply output voltage to approximately 0 V.
2. Remove the AP015 from the oscilloscope, and reconnect using the ProBus extension cable. Install a BNC T connector, BNC cable, and BNC to dual banana plug adapter as shown in the figure on the following page. Connect the dual banana plug adapter into one of the digital multimeters.
3. Using banana patch cords, connect the 'V Source' terminal of the 50 Turn Calibration Loop, AP015-CF01, to the positive output of the power supply. Connect the 'V Return' terminal to the power supply negative terminal. (Refer to Figure 1, DC Accuracy Test Set Up.)
4. Connect the Current Sense terminals of the 50 Turn Calibration Loop to the voltage inputs of the second digital multimeter.

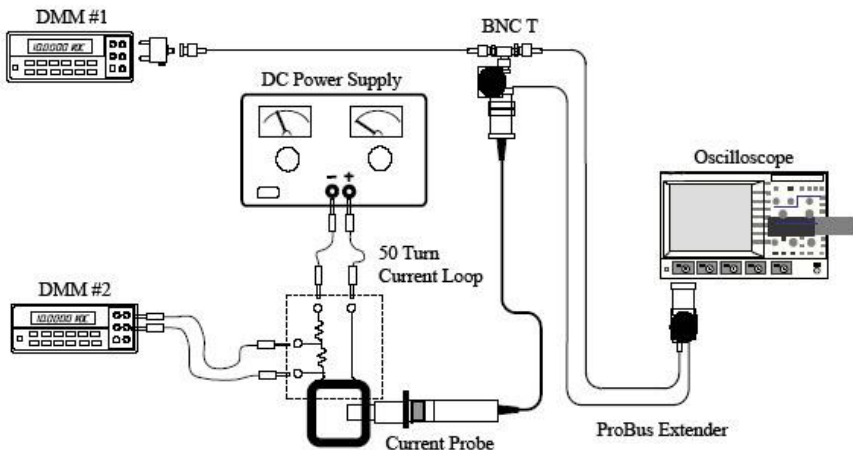

Figure 1, DC Accuracy Test Set Up

5. With the AP015 removed from any signal and the slider returned to the LOCKED position, degauss the probe by pressing the DEGAUSS button (located in the Coupling menu) twice.

6. Open the AP015 slider and position the probe input around the 50 Turn loop. Close and LOCK the slider.
7. Set the oscilloscope channel vertical scale to 20 A/div.
8. With the power supply set to 0 V, press the 'Null' button of the multimeter measuring the probe voltage to subtract the probe's offset voltage from the measurement. (If the multimeter being used does not have this capability, the offset value can be manually subtracted from the probe output values recorded below.)
9. Increase the power supply voltage until the voltage measured at the 'Current Sense' terminals (DMM #2) is approximately 150 mV. (This corresponds to 15 A at the probe head).
10. Record the exact value (a) of the current sense voltage measured with DMM #2 on the test record line marked '15 A Current Sense,' and (b) the probe output voltage measured with DMM #1 on the line marked '15 A Probe Output.'
11. Multiply the value recorded for '15 A Current Sense' by 10, and record this value on the line labeled '15 A Current'.
12. Calculate the percentage difference between the probe output voltage and the actual current using the equation $100 * (b - c)/c$. Record this value on the line marked '15 A Accuracy.'
13. Verify that the 15 A Accuracy is $< \pm 1\%$.
14. Increase the power supply voltage until the voltage measured at the 'Current Sense' terminals is approximately 300 mV. (This corresponds to 30 A at the probe head).
15. Record the exact value (d) of the current sense voltage on the test record line marked '30 A Current Sense,' and (e) the probe output voltage on the line marked '30 A Probe Output.'
16. Multiply the value recorded for '30 A Current Sense' by 10, and record this value on the line labeled '30 A Current'.
17. Calculate the percentage difference between the probe output voltage and the actual current using the equation $100 * (e - f)/f$. Record this value on the line marked '30 A Accuracy.'

ADP015 Current Probe

18. Verify that the 30 A Accuracy is $< \pm 2\%$.
19. Leave the connection set up for the remaining test.

C. Check Peak Current



CAUTION. This test increases the power dissipated inside the probe. Do not leave the increased current turned on longer than needed to complete the test (10 seconds).

1. Increase the power supply voltage until the voltage measured at the 'Current Sense' terminals is > 500 mV. (This corresponds to > 50 A at the probe head.)
2. Note the probe output voltage. Verify that the voltage remains stable without significant decrease for 10 seconds before shutting the current off. Record the value on the line marked '50 A DC Current' on the test record.

This completes the Performance Verification of the AP015. Complete and file the results recorded in the AP015 Performance Verification Test Record as required by your quality procedures. Apply a suitable calibration label to the AP015 housing as required.

Adjustment Procedure

This procedure can be used to adjust the AP015 Current Probe in order to meet the warranted gain specification. The other parameters verified in the Performance Verification procedure do not have adjustments associated with them. This procedure should only be performed if the instrument fails to meet the Performance Verification tests. If the probe cannot be adjusted to meet the Performance Verification limits, repair may be necessary.

To ensure instrument accuracy, check the calibration of the AP015 every year. Before calibration, thoroughly clean and inspect this unit.

Adequate guard bands were designed into this instrument to assure it will meet or exceed published specifications over the entire operating temperature range. To continue to meet the environmental specifications, all adjustments must be performed in a controlled environment with an ambient temperature of $25 \pm 5^\circ$ C. The instrument must also be at stable operating temperature before performing adjustments.



CAUTION. The adjustment procedure requires removal of the instrument covers. These covers are part of the ESD protection system of the AP015. To protect the instrument, the entire procedure should be performed on a static dissipating work surface only. The technician should wear an antistatic grounding wrist strap and follow standard static control procedures.

Test Equipment Required

The adjustment procedure requires a subset of the equipment required for Performance Verification. Refer to Table 1 located in the Performance Verification procedure.

If alternate test equipment is substituted, control settings or calibration equipment setups may need to be altered. Alternate models of test equipment may have different connector styles requiring adapters not included in the equipment list.

Preliminary Procedure

1. Remove the two screws that secure the plastic cover on the cable end of the ProBus interface housing. Gently pull on the probe cable to slide the circuit board assembly from the metal housing.
2. Connect the AP015 (without the compensation box cover) to the oscilloscope using the setup for the DC Accuracy check in the Performance Verification Procedure. (Refer to Figure 1 in the Performance Verification section).



CAUTION. The compensation box cover serves to align the ProBus connector pins during mating. With the cover removed, care must be used to assure correct alignment of the connector pins. Applying power with the pin alignment incorrect may damage the probe.

3. Turn on the oscilloscope power switch to allow the probe to warm up at least 20 minutes before proceeding with the gain adjustment.

Adjust R24, Gain

1. With the AP015 Current Probe removed from any signal and the slider returned to the LOCKED position, degauss the probe by pressing the DEGAUSS button (located on the coupling menu) twice.
2. Connect the AP015 to the 50 Turn loop, and set the oscilloscope vertical scale to 20 A/div.
3. With the power supply set to 0 V, press the 'Null' button of the multimeter measuring the probe voltage to subtract the probe's offset voltage from the measurement. (If the multimeter being used does not have this capability, the offset value can be manually subtracted from the probe output values measured).
4. Increase the power supply voltage until the voltage measured at the 'Current Sense' terminals is approximately 100 mV. (This corresponds to 10 A at the probe head).
5. Carefully adjust R24 until the value measured by the multimeter measuring the probe output is equal to 10x the value measured by the current sense meter. (There are two adjustments on the circuit board; R24 is the one farther from the board edge).

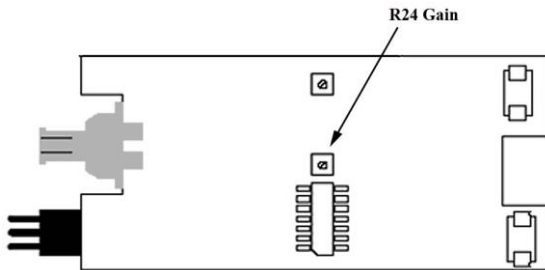

Figure 2, Gain Adjustment Location

6. After adjustment, calculate the accuracy (as in steps 15, 16, and 17 above) to confirm that the probe is measuring better than 1% accuracy.
7. Insert and tighten the two screws that secure the end panel to the ProBus interface housing. Avoid over tightening the screws, as the cover may warp.
8. Repeat the Performance Verification procedure to ensure compliance with the warranted specifications.

Certifications

EMC Compliance

EC DECLARATION OF CONFORMITY - EMC

The probe meets intent of EC Directive 2004/108/EC for Electromagnetic Compatibility. Compliance was demonstrated to the following specifications as listed in the Official Journal of the European Communities:

EN 61326-1:2006, EN 61326-2-1:2006 EMC requirements for electrical equipment for measurement, control, and laboratory use.

Electromagnetic Emissions:

CISPR 11:2003, Radiated and Conducted Emissions Group 1, Class A ^{1 2}

Electromagnetic Immunity:

EN 61000-4-2:2001 Electrostatic Discharge, 4 kV contact, 8 kV air, 4 kV vertical/horizontal coupling planes ³

EN 61000-4-3:2006 RF Radiated Electromagnetic Field, 3 V/m, 80-1000 MHz; 3 V/m, 1400 MHz - 2 GHz; 1 V/m, 2 GHz - 2.7 GHz ³

1 Emissions which exceed the levels required by this standard may occur when the probe is connected to a test object.

2 This product is intended for use in nonresidential areas only. Use in residential areas may cause electromagnetic interference.

3 Meets Performance Criteria "B" limits of the respective standard: during the disturbance, product undergoes a temporary degradation or loss of function or performance which is self-recoverable.

European Contact:

Teledyne LeCroy Europe GmbH
Waldhofer Str 104
D-69123 Heidelberg
Germany
Tel: (49) 6221 82700

AUSTRALIA & NEW ZEALAND DECLARATION OF CONFORMITY—EMC

Probe complies with the EMC provision of the Radio Communications Act per the following standards, in accordance with requirements imposed by Australian Communication and Media Authority (ACMA):

CISPR 11:2003 Radiated and Conducted Emissions, Group 1, Class A, in accordance with EN61326-1:2006 and EN61326-2-1:2006.

ADP015 Current Probe

Australia / New Zealand Contacts:

Vicom Australia Ltd.
1064 Centre Road
Oakleigh, South Victoria 3167
Australia

Vicom New Zealand Ltd.
60 Grafton Road
Auckland
New Zealand

Safety Compliance

EC DECLARATION OF CONFORMITY – LOW VOLTAGE

The probe meets intent of EC Directive 2006/95/EC for Product Safety. Compliance was demonstrated to the following specifications as listed in the Official Journal of the European Communities:

EN 61010-1:2010 Safety requirements for electrical equipment for measurement, control, and laboratory use – Part 1: General requirements

EN 61010-2:032:2012 Safety requirements for electrical equipment for measurement, control, and laboratory use – Part 032: Particular requirements for hand-held and hand-manipulated current sensors for electrical test and measurement

Environmental Compliance

END-OF-LIFE HANDLING



The probe is marked with this symbol to indicate that it complies with the applicable European Union requirements to Directives 2002/96/EC and 2006/66/EC on Waste Electrical and Electronic Equipment (WEEE) and Batteries.



The probe is subject to disposal and recycling regulations that vary by country and region. Many countries prohibit the disposal of waste electronic equipment in standard waste receptacles. For more information about proper disposal and recycling of your Teledyne LeCroy product, please visit teledynelecroy.com/recycle.

RESTRICTION OF HAZARDOUS SUBSTANCES (ROHS)

The probe conforms to 2011/65/EU RoHS2 Directive based on the fact that it is classified as Industrial Monitoring and Control Instrument (per Article 3, Paragraph 24) and these product(s) & associated accessories are exempt from RoHS compliance until 22 July 2017 (per Article 4, Paragraph 3).

Contact Teledyne LeCroy

Teledyne LeCroy Service Centers

| | |
|---|---|
| <p>United States and Canada - World Wide Corporate Office Teledyne LeCroy Corporation 700 Chestnut Ridge Road Chestnut Ridge, NY, 10977-6499, USA Ph: 800-553-2769 / 845-425-2000 FAX: 845-578-5985 teledynelecroy.com Support: contact.corp@teledynelecroy.com Sales: customersupport@teledynelecroy.com</p> | <p>United States - Protocol Solutions Group Teledyne LeCroy Corporation 3385 Scott Boulevard Santa Clara, CA, 95054, USA FAX: 408-727-0800 teledynelecroy.com Sales and Service: Ph: 800-909-7211 / 408-727-6600 contact.corp@teledynelecroy.com Support: Ph: 800-909-7112 / 408-653-1260 psgsupport@teledynelecroy.com</p> |
| <p>European Headquarters Teledyne LeCroy SA 4, Rue Moïse Marcinhes Case postale 341 1217 Meyrin 1 Geneva, Switzerland Ph: + 41 22 719 2228 / 2323 / 2277 FAX: +41 22 719 2233 contact.sa@teledynelecroy.com applications.indirect@teledynelecroy.com teledynelecroy.com/europe Protocol Analyzers: Ph: +44 12 765 03971</p> | <p>Singapore, Oscilloscopes Teledyne LeCroy Singapore Pte Ltd. Blk 750C Chai Chee Road #02-08 Technopark @ Chai Chee Singapore 469003 Ph: ++ 65 64424880 FAX: ++ 65 64427811 Singapore, Protocol Analyzers Genetron Singapore Pte Ltd. 37 Kallang Pudding Road, #08-08 Tong Lee Building Block B Singapore 349315 Ph: ++ 65 9760-4682</p> |
| <p>China Teledyne LeCroy Corporation Beijing Rm. 2001 - Office; Rm. 2002 - Service Center Unit A, Horizon Plaza No. 6, Zhichun Road, Haidian District Beijing 100088, China Ph: ++86 10 8280 0318 / 0319 / 0320 FAX: ++86 10 8280 0316 Service: Rm. 2002 Ph: ++86 10 8280 0245</p> | <p>Korea Teledyne LeCroy Korea 10th fl. Ildong Bldg. 968-5 Daechi-dong, Gangnam-gu Seoul 135-280, Korea Ph: ++ 82 2 3452 0400 FAX: ++ 82 2 3452 0490</p> |
| <p>Taiwan LeColn Technology Co Ltd. Far East Century Park, C3, 9F No. 2, Chien-8th Road, Chung-Ho Dist., New Taipei City, Taiwan Ph: ++ 886 2 8226 1366 FAX: ++ 886 2 8226 1368</p> | <p>Japan Teledyne LeCroy Japan Hobunsha Funchu Bldg, 3F 3-11-5, Midori-cho, Fuchu-Shi Tokyo 183-0006, Japan Ph: ++ 81 4 2402 9400 FAX: ++ 81 4 2402 9586 teledynelecroy.com/japan</p> |

Appendix A: Performance Verification Test Record

Permission is granted to photocopy this form and use it to record the results of measurements made during the performance verification of the AP015 Current Probe. File the completed record as required by applicable internal quality procedures.

Each section of the test record corresponds to the parameters tested in the performance verification procedure. The numbers preceding the individual data records correspond to the steps in the procedure that require recording of data.

Results recorded in the right-most column, labeled "Test Result" are the actual specification limit check. The test limits are included in all of these steps. Other measurements and the results of intermediate calculations that support the limit check are recorded in the center column labeled "Intermediate Data."

Permission is granted to reproduce this page for the purpose of recording test results.

AP015 Test Record

Serial Number: _____

Asset or Tracking Number: _____

Date: _____

Technician: _____

Equipment Used

| | MODEL | SERIAL NUMBER | CALIBRATION DUE DATE |
|--|-------|---------------|----------------------|
| Digital Multimeter #1 | | | |
| Digital Multimeter #2 | | | |
| High frequency Sine Wave Generator | | | |
| Power Meter (If used to level Sine Wave Generator) | | | |

NOTES: _____

Test Date: _____ S/N: _____ ID#: _____

Technician: _____ Temp: _____ Humidity: _____

Before Results _____ After Results _____

Comments: _____

Results

| Step | Description | Intermediate Data | Test Result |
|----------------------|------------------------------|-------------------|-------------|
| Bandwidth: | | | |
| A-8 | Probe Bandwidth (> 50 MHz) | _____ MHz | |
| DC Accuracy: | | | |
| B-10a | 15 A Current Sense (a) | _____ V | |
| B-10b | 15 A Probe Output (b) | _____ V | |
| B-11 | 15 A Current (c) | _____ A | |
| B-12 | 15 A Accuracy (< $\pm 1\%$) | | _____ % |
| B-15a | 30 A Current Sense (d) | _____ V | |
| B-15b | 30 A Probe Output (e) | _____ V | |
| B-16 | 30 A Current (f) | _____ A | |
| B-17 | 30 A Accuracy (< $\pm 2\%$) | | _____ % |
| Peak Current: | | | |
| C-2 | 50 A DC Current (> 10 s) | | _____ s |



700 Chestnut Ridge Road
Chestnut Ridge, NY 10977
USA

teledynelecroy.com