



75HBAW4_2.25 series

75W - Single Output DC-DC Converter - Wide Input - Isolated & Regulated

DC-DC Converter 75W

- ⊕ Wide input voltage range: 4:1
- ⊕ High efficiency up to 92%
- ⊕ Isolation voltage 2.25kVDC
- ⊕ Operating temperature range: -40°C ~ +87°C
- ⊕ Short circuit protection (SCP)
- ⊕ Regulated Output Types
- ⊕ No Minimum Load Required
- ⊕ International standard pin-out: 1/2 brick

The 75HBAW4_2.25 series contains isolated 75W DC-DC products with 4:1 input voltage. They feature efficiency up to 91%, 2250VDC isolation, operating temperature of -40°C to +70°C, over voltage protection, output power and short circuit protection.

They are widely applied in battery power supplies, industrial control, electricity, instruments, railway, communication, intelligence robot fields.



Common specifications	
Short circuit protection:	Hiccup, Auto-Recovery
Cooling:	Natural Convection
Operating Temperature:	-40°C ~ +59°C / ~ +69°C
Storage temperature range:	-55°C ~ +125°C
Operating case temperature:	-40°C ~105°, base-plate
Storage humidity range:	Non-condensing - 95%RH (Max.)
Pin welding resistance temperature:	260°C MAX, wave soldering for 10 sec.
Thermal Shock:	MIL-STD-810F
Shock &Vibration Test:	MIL-STD-810F
Case material:	Aluminum Base-plate with Plastic Case
Switching frequency:	Full Load, Nominal Input: Typ. 220KHz
MTBF (MIL-HDBK-217F @25°C):	3.547 X 10 ⁵ Hours
Dimension:	61 x 57.9 x 15.0mm
Weight:	100g

Input specifications					
Item	Test condition	Min	Typ	Max	Units
Input surge voltage	• 24V	-0.7		50	VDC
	• 48V	-0.7		100	VDC
	• 110V	-0.7		170	VDC
Start-up voltage	• 24V			9	VDC
	• 48V			18	VDC
	• 110V			40	VDC
Under-voltage lockout	• 24V		7.5		V
	• 48V		16		V
	• 110V		36		V
Input filter	Internal Pi network				
Start-up time (constant resistive load)	Power-up		30		ms
	Remote ON/OFF		30		ms
Remote ON/OFF (refer to -Vin pin)	Positive logic				
	ON: open	3.5		12	VDC
	OFF: Short	0		1.2	VDC
Input current of Ctrl PIN	Remote off input current	-0.5		0.5	mA
			3		mA

Example:
75HBAW4_4812S2.25
 75 = 75 Watt; HB = Half Brick; A = series; W4 = Wide input (4:1);
 48 = 18-75Vin; 12Vout; S = Single Output; 2.25 = 2250 VDC isolation

Output specifications					
Item	Test condition	Min	Typ	Max	Units
Voltage tolerance				±1	%
Voltage adjustability	max. output deviation is inclusive of remote sense			±10	%
Line regulation	Nom. input voltage			±0.2	%
Load regulation	Single output models			±0.2	%
Remote sense*	% of Vout(nom)			±10	%
Ripple & Noise (BW = 20MHz)	• 5V (1uF MLCC/33uF Polytan)			100	mVp-p
	• 12V/15V (1uF MLCC/33uF Polytan)			125	mVp-p
	• 24V (4.7uF MLCC)			250	mVp-p
Transient response setting time	25% load step change		350	500	µs
Transient response deviation	25% load step change			±5	%
Output power protection	Hiccup, Auto-Recovery	120	150	180	%
Over temperature protection	Base-plate		+115		°C
Over voltage protection	• 5VDC			6.2	VDC
	• 12VDC			15	VDC
	• 15VDC			18	VDC
	• 24VDC			30	VDC

* If remote sense is not being used, sense pins should be connected to corresponding polarity OUTPUT pins.

Isolation specifications					
Item	Test condition	Min	Typ	Max	Units
Isolation voltage*	• Input-output	2250			VDC
	• Input-case	1600			VDC
Isolation resistance	500VDC	1000			MΩ
Isolation capacitance				2600	pF

Note:

- The maximum capacitive load offered were tested at input voltage range and full load;
- Unless otherwise specified, data in this datasheet should be tested under the conditions of Ta = 25°C, humidity <75%RH when inputting nominal voltage and outputting rated load;
- All index testing methods in this datasheet are based on our Company's corporate standards;
- We can provide product customization service and match filter module;
- Specifications of this product are subject to changes without prior notice.

75HBAW4_1.5 series

75W - Single Output DC-DC Converter - Wide Input - Isolated & Regulated

EMC specifications

EMI	CE	EN55032, EN55011, FCC part 15		performance: TBD
EMS	RE	EN55024		performance: TBD
EMS	ESD	IEC 61000-4-2	air	performance: TBD
EMS	RS	IEC 61000-4-3	10V/m	performance: TBD
EMS	EFT	IEC 61000-4-4	±2kV	performance: TBD
EMS	Surge	IEC 61000-4-5	±2kV	performance: TBD
EMS	CS	IEC 61000-4-6	10Vrms	performance: TBD

Product Selection Guide

Part Number	Input Voltage [VDC]		Input current [mA]		Output Voltage [VDC]	Output current [mA]	Efficiency [%, typ]	Capacitor load [μF]
	Nominal	Range	no load	full load				
75HBAW4_2405S2.25	24	9-36	100	3434	5	15000	91	30000
75HBAW4_2412S2.25	24	9-36	100	3434	12	6250	91	5200
75HBAW4_2415S2.25	24	9-36	100	3434	15	5000	91	3300
75HBAW4_2424S2.25	24	9-36	100	3472	24	3125	90	1300
75HBAW4_4805S2.25	48	18-75	75	1717	5	15000	91	30000
75HBAW4_4812S2.25	48	18-75	75	1698	12	6250	92	5200
75HBAW4_4815S2.25	48	18-75	75	1698	15	5000	92	3300
75HBAW4_4824S2.25	48	18-75	75	1717	24	3125	91	1300
75HBAW4_11005S2.25	110	40-160	35	757	5	15000	90	30000
75HBAW4_11012S2.25	110	40-160	35	749	12	6250	91	5200
75HBAW4_11015S2.25	110	40-160	35	749	15	5000	91	3300
75HBAW4_11024S2.25	110	40-160	35	749	24	3125	91	1300

Typical characteristics

Temperature derating graph

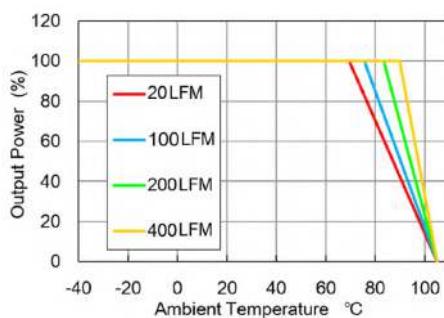

75HBAW4_4812S2.25 and 75HBAW4_4815S2.25

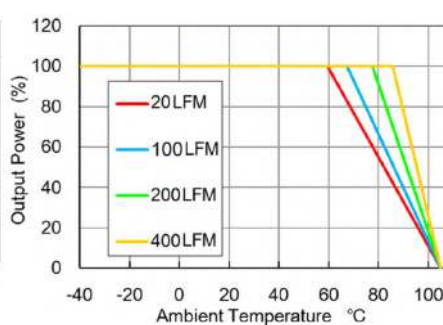

75HBAW4_2424S2.25 and 75HBAW4_11005S2.25

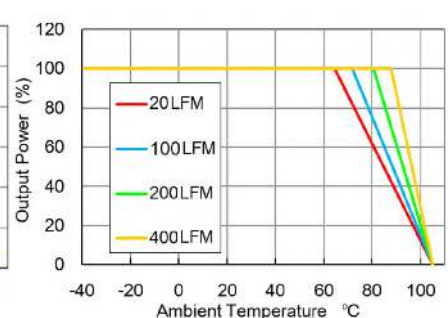

All other models

75HBAW4_1.5 series

75W - Single Output DC-DC Converter - Wide Input - Isolated & Regulated

Characteristic Curve

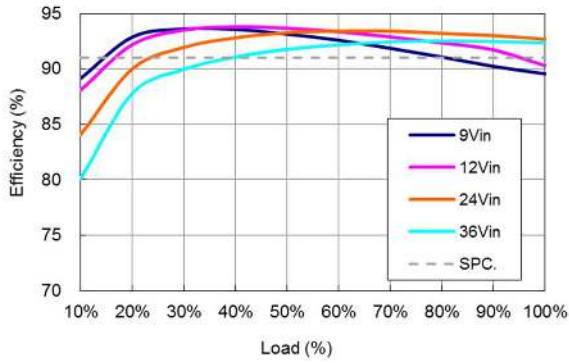

75HBAW4_2405S2.25

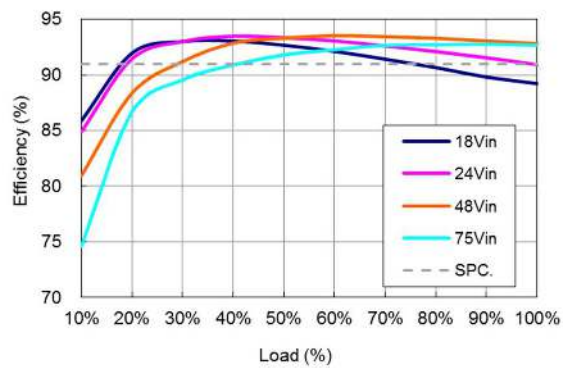
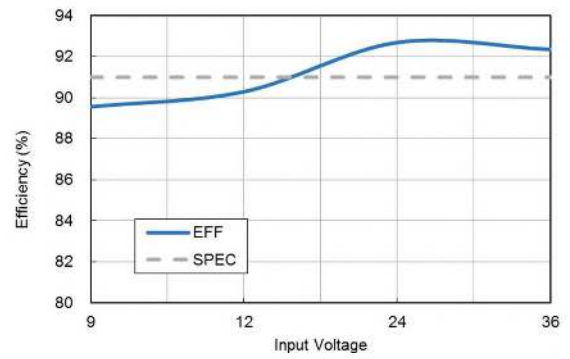

75HBAW4_4805S2.25

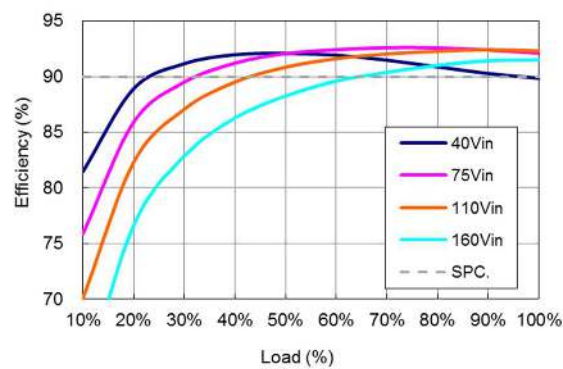
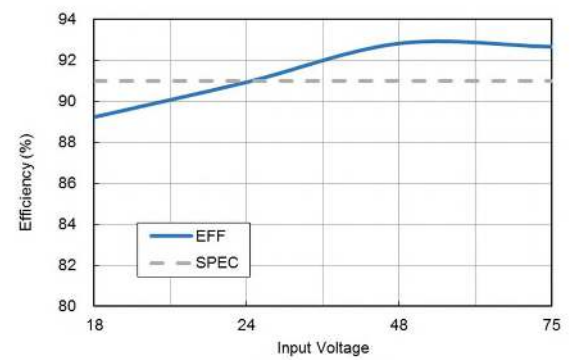

75HBAW4_11005S2.25

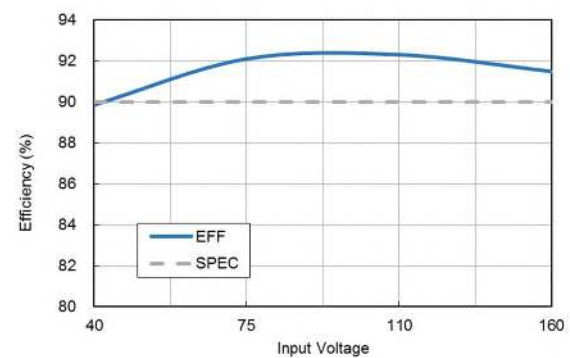

75HBAW4_1.5 series

75W - Single Output DC-DC Converter - Wide Input - Isolated & Regulated

Resistive load, nominal Vin

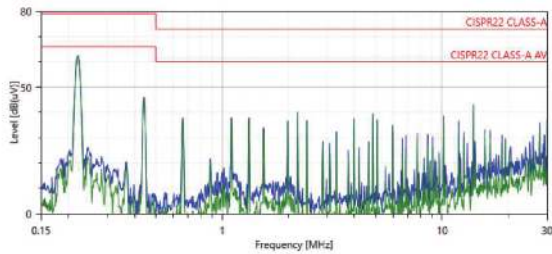

Line

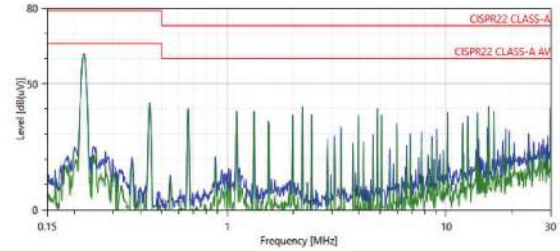

Neutral

Radiated Emission

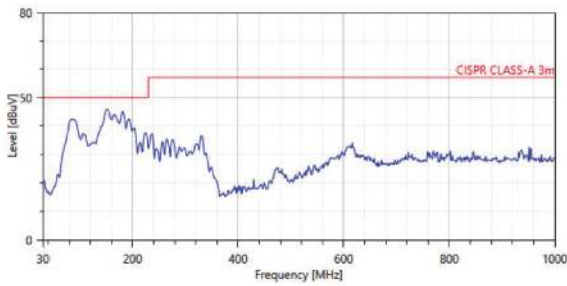

Horizontal

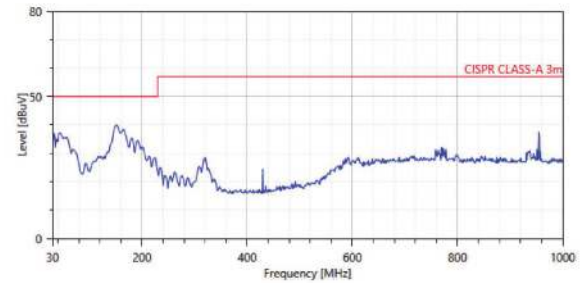

Vertical

EMI Filtering Suggestion

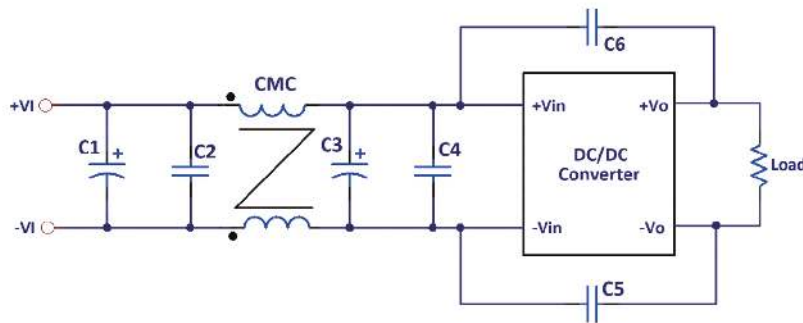

75HBAW4_2405S2.25

Component List

C1	C2	C3	C4	C5	C6	CMC
120uF/63V	4.7uF/100V	120uF/63V	4.7uF/100V	2000pF	2000pF	0.15mH

75HBAW4_1.5 series

75W - Single Output DC-DC Converter - Wide Input - Isolated & Regulated

Mechanical dimensions

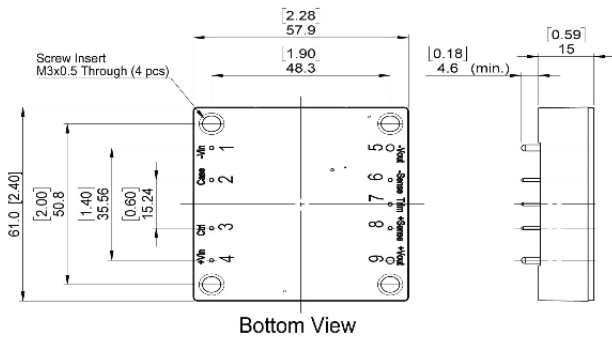

Bottom View

Unit : mm [inch]

Tolerance : XX.X ±0.5 , XX.XX ±0.25

Screw mounting hole size \varnothing 3.5mm is recommend

Pin assignment

Pin	Define	Diameter
1	-Vin	1.0mm[0.04"]
2	Case	1.0mm[0.04"]
3	Ctrl	1.0mm[0.04"]
4	+Vin	1.0mm[0.04"]
5	-Vout	2.0mm[0.08"]
6	-Sense	1.0mm[0.04"]
7	Trim	1.0mm[0.04"]
8	+Sense	1.0mm[0.04"]
9	+Vout	2.0mm[0.08"]

Application Examples

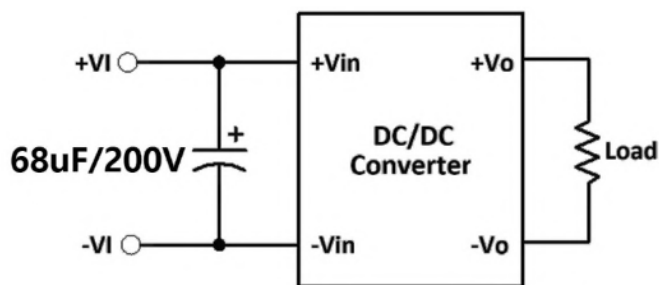

It is necessary to parallel a capacitor across the input pins under normal operation.
Minimum Capacitance: 68µF/ 200V.