

CATALOG NUMBER	MATERIAL NUMBER	CABLE RANGE	NOMINAL ROD DIAMETER	LENGTH "M"	LENGTH "B"	APPROXIMATE BREAK STRENGTH* (LBS / N)	UL LISTED	CSA APPROVED	PRODUCT SELECTION NUMBER
35850	1300950122	.50-.61 / 12.7-15.5	.55 / 14.0	11.00±1.50 / 279.4±38.1	5.00±0.50 / 127.0±12.7	5600 / 24910	NO	YES	PS050-1
35851	1300950123	.62-.74 / 15.7-18.8	.68 / 17.3	11.00±1.50 / 279.4±38.1	5.00±0.50 / 127.0±12.7	6800 / 30248			PS062-1
35867	1300950126	.75-.99 / 19.1-25.1	.87 / 22.1	20.00±2.00 / 508.0±50.8	6.00±0.50 / 152.4±12.7	9600 / 42703			PS075-2
35868	1300950127	1.00-1.24 / 25.4-31.5	1.12 / 28.4	20.00±2.00 / 508.0±50.8	7.00±1.00 / 177.8±25.4	16400 / 72951			PS100-2
35869	1300950128	1.25-1.49 / 31.8-37.8	1.37 / 34.8	21.00±2.50 / 533.4±63.5	7.00±1.00 / 177.8±25.4	16400 / 72951			PS125-2
35870	1300950129	1.50-1.99 / 38.1-50.5	1.74 / 44.2	25.00±2.50 / 635.0±63.5	7.00±1.00 / 177.8±25.4	27200 / 120992			PS150-2
35871	1300950130	2.00-2.49 / 50.8-63.2	2.24 / 56.9	26.00±2.50 / 660.4±63.5	8.00±1.00 / 203.2±25.4	33000 / 146791			PS200-2
35872	1300950131	2.50-2.99 / 63.5-75.9	2.74 / 69.6	28.00±2.50 / 711.2±63.5	10.00±1.00 / 254.0±25.4	41000 / 182377			PS250-2
35873	1300950132	3.00-3.49 / 76.2-88.6	3.24 / 82.3	30.00±3.50 / 762.0±88.9	10.00±1.00 / 254.0±25.4	48000 / 213515			PS300-2
35874	1300950133	3.50-3.99 / 88.9-101.3	3.74 / 95.0	32.00±3.50 / 812.8±88.9	10.00±1.00 / 254.0±25.4	48000 / 213515			PS350-2
35875	1300950134	4.00-4.49 / 101.6-114.0	4.24 / 107.7	33.00±3.50 / 838.2±88.9	10.00±1.00 / 254.0±25.4	48000 / 213515	PS400-2		

*TO DETERMINE RECOMMENDED WORKING LOAD, DIVIDE BREAK STRENGTH BY 5.

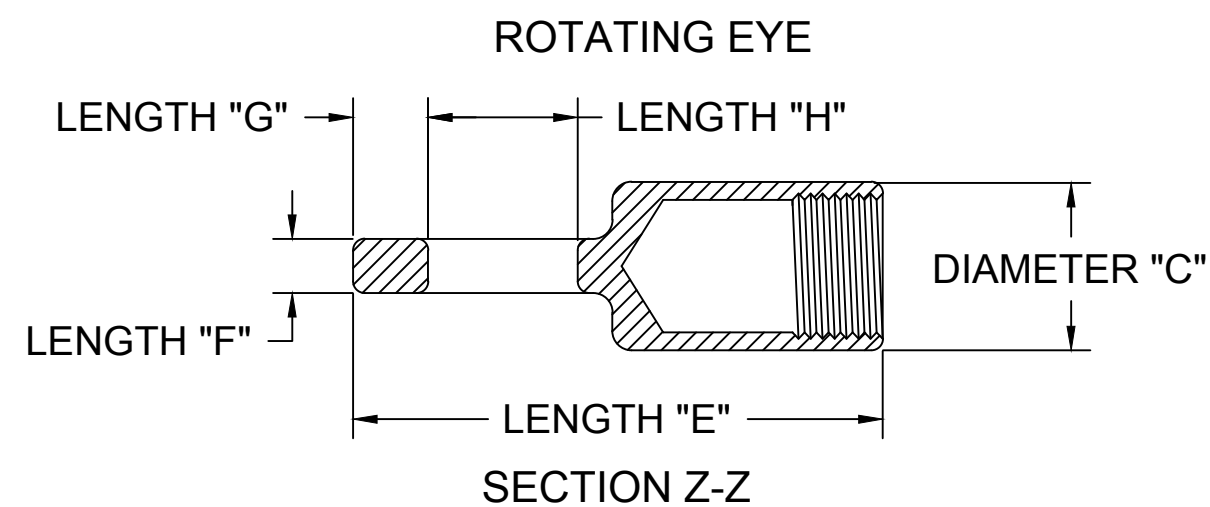

ROTATING EYE DIMENSIONS - REFERENCE						
CATALOG NUMBER	DIAMETER "C"	LENGTH "D"	LENGTH "E"	LENGTH "F"	LENGTH "G"	LENGTH "H"
35850	.875 / 22.23	.187 / 4.75	2.750 / 69.85	.281 / 7.14	.250 / 6.35	.875 / 22.23
35851	.875 / 22.23	.187 / 4.75	2.750 / 69.85	.281 / 7.14	.250 / 6.35	.875 / 22.23
35867	1.000 / 25.40	.219 / 5.56	3.625 / 92.08	.500 / 12.70	.312 / 7.92	.906 / 23.01
35868	1.375 / 34.93	.344 / 8.74	4.625 / 117.48	.500 / 12.70	.375 / 9.53	1.000 / 25.40
35869	1.375 / 34.93	.344 / 8.74	4.625 / 117.48	.500 / 12.70	.375 / 9.53	1.000 / 25.40
35870	1.375 / 34.93	.344 / 8.74	4.625 / 117.48	.500 / 12.70	.375 / 9.53	1.000 / 25.40
35871	1.625 / 41.275	.375 / 9.53	5.437 / 138.10	.625 / 15.88	.500 / 12.70	1.187 / 30.15
35872	1.875 / 47.625	.437 / 11.1	6.250 / 158.75	.656 / 16.66	.500 / 12.70	1.375 / 34.93
35873	1.875 / 47.625	.437 / 11.1	6.250 / 158.75	.656 / 16.66	.500 / 12.70	1.375 / 34.93
35874	1.875 / 47.625	.437 / 11.1	6.250 / 158.75	.656 / 16.66	.500 / 12.70	1.375 / 34.93
35875	1.875 / 47.625	.437 / 11.1	6.250 / 158.75	.656 / 16.66	.500 / 12.70	1.375 / 34.93

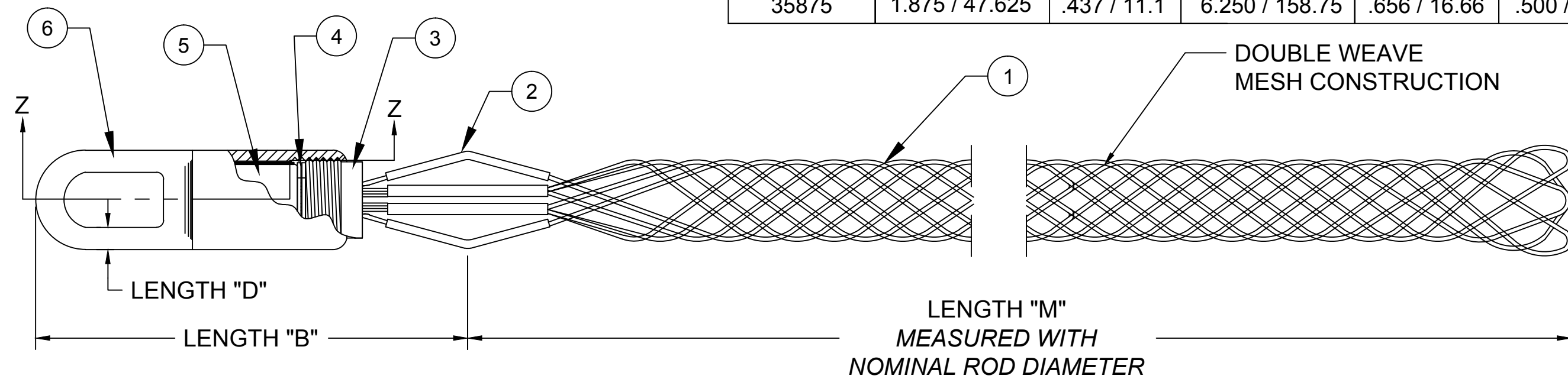

INSTRUCTION SHEET TO BE INCLUDED WITH GRIP.

ITEM	DESCRIPTION	MATERIAL
1	WIRE MESH	GALVANIZED STEEL
2	SHOULDER PROTECTOR	ALUMINUM
3	THREADED INSERT	STEEL
4	FLAT WASHERS	NYLATRON
5	SWAGING FERRULE	STEEL
6	ROTATING EYE	STEEL

RELEASE SALES DRAWING	QUALITY SYMBOL
EC NO.: IFCG2014-1924	▽=0
DRWN: HRUIZ01 2014/09/03	▽C=0
CHKD: HKNEELAN 2014/09/03	
APPR: JFMURPHY 2015/03/23	
REV	
A	

GENERAL TOLERANCES (UNLESS SPECIFIED)	
	mm INCH
4 PLACES	±--- ±---
3 PLACES	±--- ±.005
2 PLACES	±.13 ±.010
1 PLACE	±.25 ±.020
ANGULAR ±1/2°	
DRAFT WHERE APPLICABLE MUST REMAIN WITHIN DIMENSIONS	

DIMENSION STYLE INCH/MM		
SCALE NTS	DESIGN UNITS INCH	
DRAWN BY DATE	TITLE	
HRUIZ01 2014/09/03	PULLING GRIPS HEAVY DUTY K-TYPE SHORT LENGTH	
CHECKED BY DATE	MOLEX INCORPORATED	
HKNEELAN 2014/09/03		
APPROVED BY DATE	DOCUMENT NO.	
JFMURPHY 2015/03/23	SD-130095-106	
MATERIAL NO.	SHEET NO.	
SEE TABLE	1 OF 1	
SIZE C	THIS DRAWING CONTAINS INFORMATION THAT IS PROPRIETARY TO MOLEX INCORPORATED AND SHOULD NOT BE USED WITHOUT WRITTEN PERMISSION	