



EV6500A-F-01A

35V, 2.5A Bipolar Stepper Motor Driver Evaluation Board

DESCRIPTION

The EV6500A-F-01A is an evaluation board for the MP6500AGF, a stepper motor driver with a built-in micro stepping translator.

It operates from a supply voltage of up to 35V and can deliver motor current up to 2.5A. It can operate a bipolar stepper motor in full- half-, quarter-, and eighth- step modes by setting the MS2, MS1. The input control signals for the MP6500AGF are applied through the connector or generated on board.

ELECTRICAL SPECIFICATIONS

Parameter	Symbol	Value	Units
Input Voltage	V _{IN}	4.5 - 35	V
Maximum Output Current	I _{OUT-L}	2.5	A
Decay Mode	Automatic Decay		

FEATURES

- Wide 4.5V to 35V Input Voltage Range
- Up to 2.5A Programmable Output Current
- Full-, Half-, Quarter-, and Eighth- Step Mode
- Automatic Decay Mode
- OCP, OVP, OTP
- Fault Indication Output

APPLICATIONS

- Bipolar Stepper Motors
- Printers

All MPS parts are lead-free, halogen-free, and adhere to the RoHS directive. For MPS green status, please visit the MPS website under Quality Assurance. "MPS" and "The Future of Analog IC Technology" are registered trademarks of Monolithic Power Systems, Inc.

EV6500A-F-01A EVALUATION BOARD



(L x W x H) 2.54" x 2.54" x 0.4"
(6.35cm x 6.35cm x 1cm)

Board Number	MPS IC Number
EV6500A-F-01A	MP6500AGF

EVALUATION BOARD SCHEMATIC

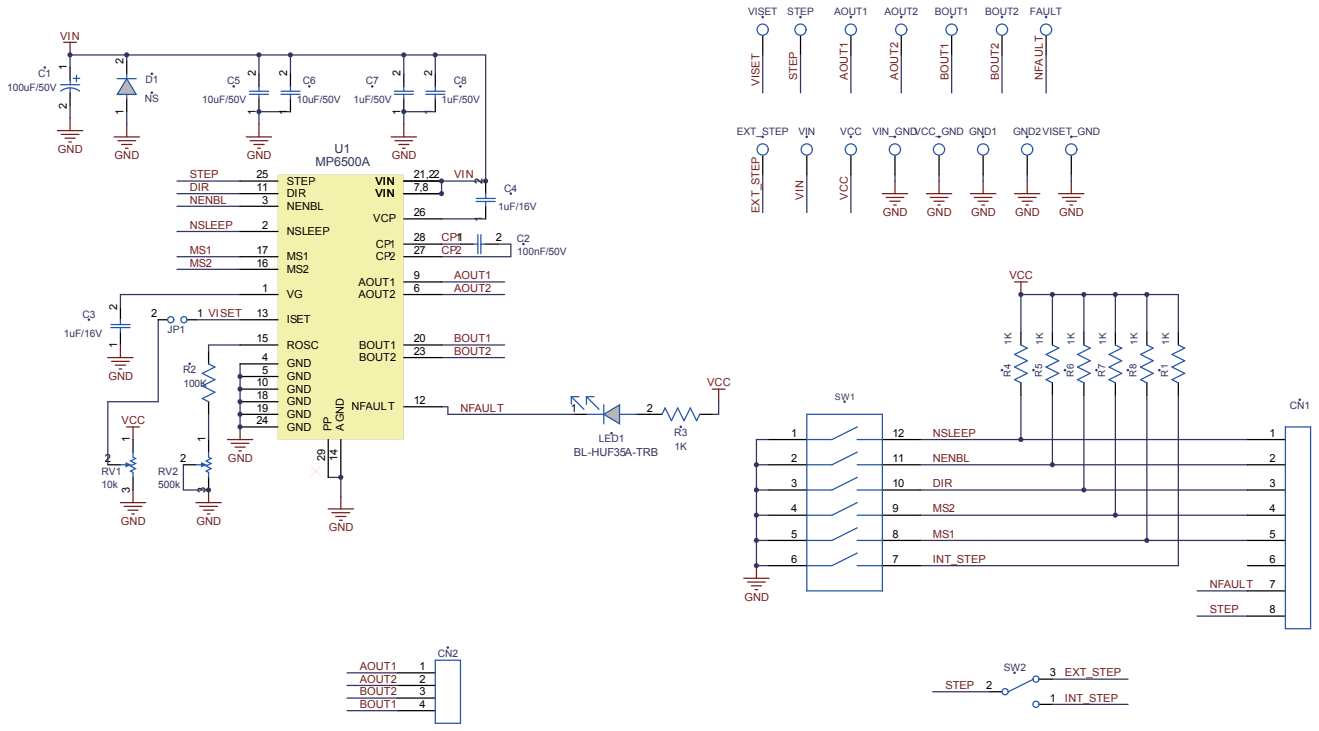

EV6500A-F-01A BILL OF MATERIALS

Qty	RefDes	Value	Description	Package	Manufacturer	Manufacturer P/N
1	C1	100μF/ 50V	Electrolytic Capacitor;50V;Electroly tic	DIP	Rubycon	50YXF100MEFC
1	C2	100nF/ 50V	Ceramic Capacitor;50V;X7R	0603	muRata	GRM188R71H104KA93D
2	C3, C4	1μF/16 V	Ceramic Capacitor;16V;X7R;	0603	muRata	GRM188R71C105KA12D
2	C5, C6	10μF/5 0V	Ceramic Capacitor;50V;X7R	1210	muRata	GRM32ER71H106KA12L
2	C7, C8	1μF/50 V	Ceramic Capacitor;50V;X7R	0805	muRata	GRM21BR71H105KA12L
7	R1, R3, R4, R5, R6, R7, R8	1K	Film Resistor;1%	0603	Yageo	RC0603FR-071KL
1	R2	100K	Film Resistor;1%	0603	Yageo	RC0603FR-07100KL
1	RV1	10k	Adjustable Resistor	DIP		3266W-1-103F
1	RV2	500k	Adjustable Resistor	DIP		3266W-1-504LF
1	LED1		LED;红光;	0805	佰鸿	2012SURC-11
1	SW1		6-Bits Dial Switch	SMD	Würth	418121270806
1	SW2		Button			SS-12D01EG4
1	CN1		8PIN. 2.54MM Connector			61304011121
1	CN2		4PIN. 2.54MM Connector			61304011121
1	JP1		2PIN. 2.54MM Connector			61304011121
1	D1	NS				
2	STEP, FLT		Test Point			
2	VIN, VIN_GND		2.0 公针			
11	VCC, EXT_STE P, VISET, AOUT1, AOUT2, BOUT1, BOUT2, GND1, GND2, GND3, GND4		1.0 公针			
1	U1		Stepper Motor Driver	TSSOP2 8-EP	MPS	MP6500AGF

PRINTED CIRCUIT BOARD LAYOUT

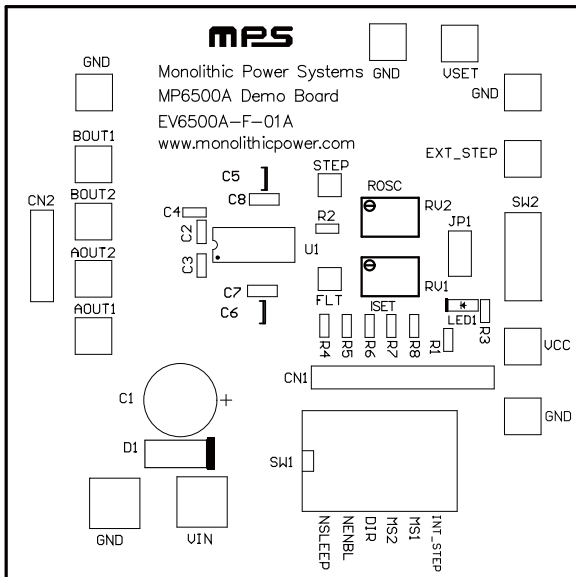

Figure 1: Top Silk Layer

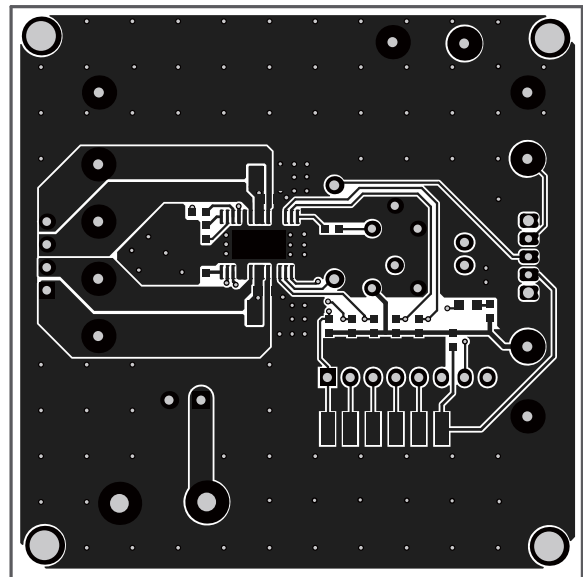

Figure 2: Top Layer

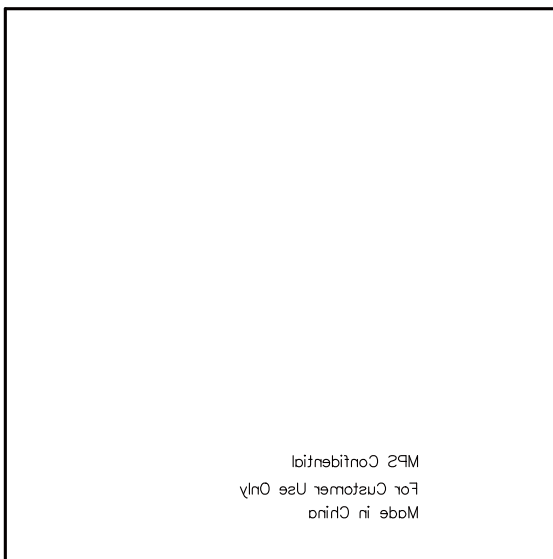

Figure 2: Bottom Silk Layer

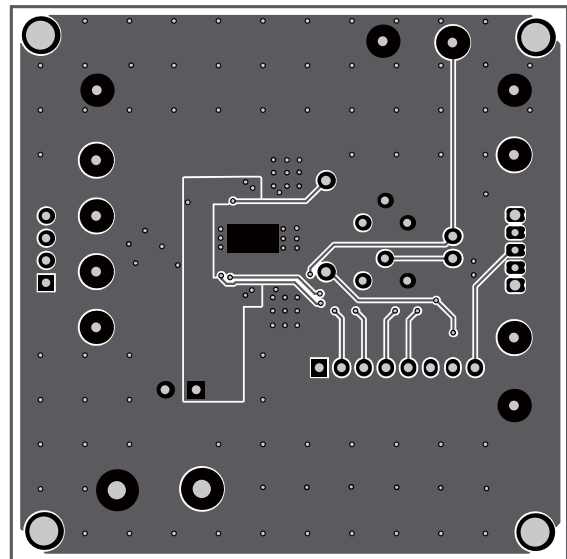

Figure 4: Bottom Layer

QUICK START GUIDE

1. Attach the input voltage ($4.5V \leq V_{IN} \leq 35V$) and input ground to the VIN and GND connectors respectively.
2. Output current limit is programmed by the VSET pin with two methods:
 - a. Remove the JP1 jumper and attach the external 0V to 2V voltage to the VSET connector.
 - b. Add the JP1 jumper and adjust RV1 by manual action. Manual action requires an external 3.3V or 5V VCC voltage as a pull-up power supply.
3. Switch the SW2 to the position 3(Top side) to enable external step signal input from the EXT_STEP connector.
4. Attach the step signal to the EXT_STEP connector.
5. Input control and logic signal can be set either through the CN1 connector by the external MCU or through the SW1 by manual action. Manual action requires an external 3.3V or 5V VCC voltage as a pull-up power supply.

NOTICE: The information in this document is subject to change without notice. Users should warrant and guarantee that third party Intellectual Property rights are not infringed upon when integrating MPS products into any application. MPS will not assume any legal responsibility for any said applications.