

© - TE Connectivity. All Rights Reserved.

REVISIONS				
P	LTR	DESCRIPTION	DATE	APVD
	A2	REV PER ECN-22-150900	28APR2022	RK CSD

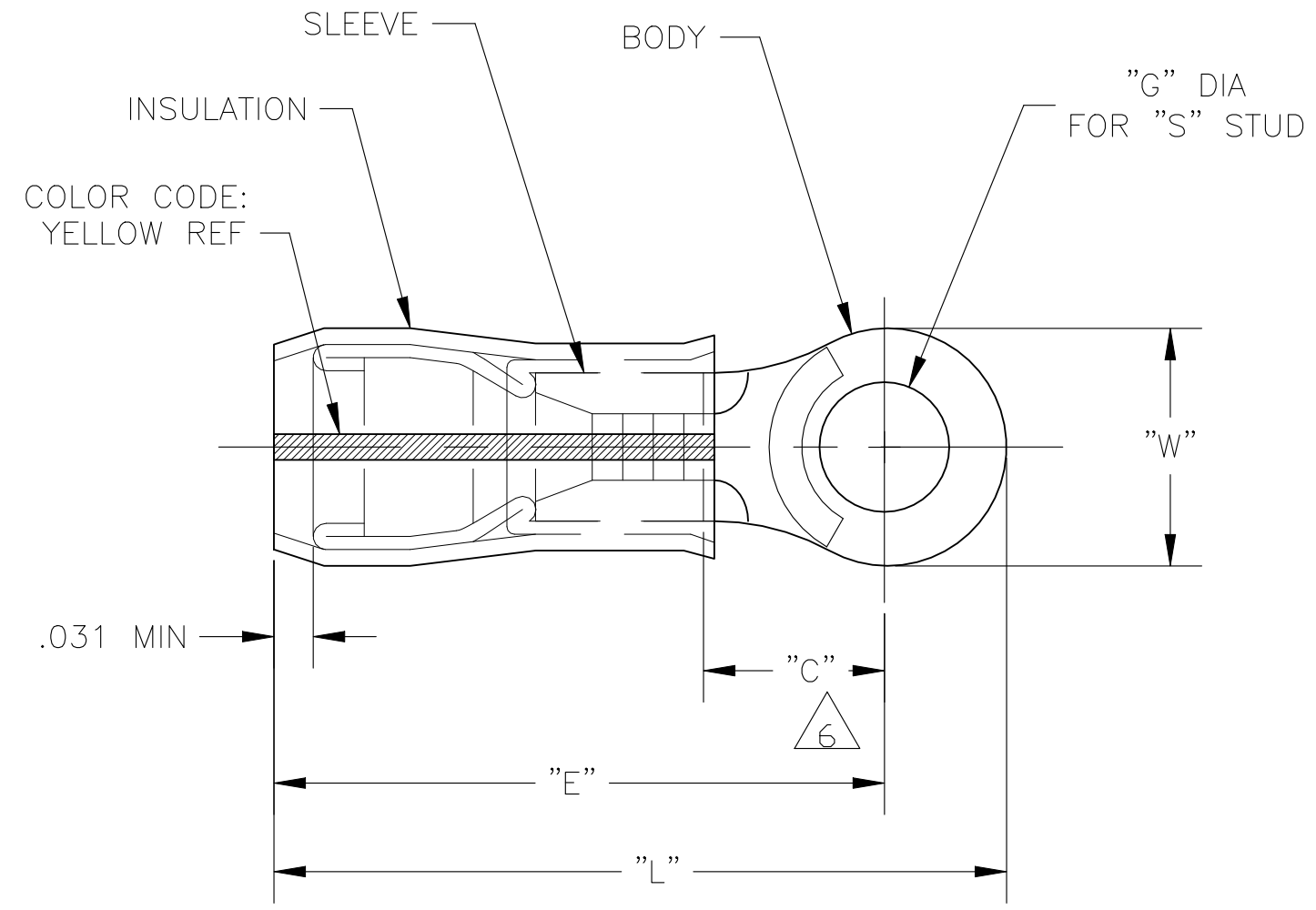

- 1 STAMP AMP 12-10* APPROX AS SHOWN
- 2 WIRE INSULATION DIA: .150-.230
- 3 TONGUE MATERIAL THK: .039±.002
- 4 BODY & SLEEVE: TIN PLATE PER ASTM B545,
- 5 BODY & SLEEVE- CU PER ASTM B152
INSULATION - PVF2, COLOR - NATURAL
- 6 APPLIES FROM EDGE OF METAL WIRE BARREL TO CENTER OF STUD HOLE.

.715	.474 MIN	1.054 MAX	.515±.005	1/2"	1.419 MAX	500	LOOSE PIECE	1-696424-0
.593	.531 MIN	1.115 MAX	.390±.005	3/8"	1.419 MAX	500	LOOSE PIECE	696424-9
.531	.468 MIN	1.054 MAX	.328±.005	5/16"	1.327 MAX	500	LOOSE PIECE	696424-8
.531	.468 MIN	1.054 MAX	.265±.005	1/4"	1.327 MAX	500	LOOSE PIECE	696424-7
.375	.302 MIN	.893 MAX	.197±.003	#10	1.088 MAX	500	LOOSE PIECE	696424-6
.375	.302 MIN	.893 MAX	.171±.003	#8	1.088 MAX	500	LOOSE PIECE	696424-5
.375	.302 MIN	.893 MAX	.145±.003	#6	1.088 MAX	500	LOOSE PIECE	696424-4
"W"	"C"	"E"	"G" DIA	"S"	"L"	QTY	PACKAGE TYPE	PART NO

AMP INCORPORATED CUSTOMER SERVICE SYSTEMS		MAX RECOMMENDED OPERATING TEMPERATURE: 150°C MAX	THIS DRAWING IS A CONTROLLED DOCUMENT.		DWN JR RUTH 25JUL05	TE Connectivity NAME TERMINAL, RING TONGUE, PVF2, P.I.D.G. WIRE SIZE: 12-10 AWG					
FOR ADDITIONAL PRODUCT INFORMATION OR COPIES OF DRAWINGS AND TECHNICAL DOCUMENTS	PRODUCT INFORMATION CENTER 1-800-522-6752	VOLTAGE RATING: -	DIMENSIONS: INCHES	TOLERANCES UNLESS OTHERWISE SPECIFIED:	CHK T MICHIELUTTI 25JUL05				APVD T MICHIELUTTI 25JUL05	SIZE	CAGE CODE
FOR APPLICATION TOOLING INFORMATION	TOOLING ASSISTANCE CENTER 1-800-722-1111	CIRCULAR MIL AREA: 2.62-6.64mm² [5,180-13,100] STRANDED		0 PLC ± - 1 PLC ± - 2 PLC ± - 3 PLC ± - 4 PLC ± - ANGLES ± -	APVD T MICHIELUTTI 25JUL05	PRODUCT SPEC	---	---	---	---	
FOR ORDER ENTRY	1-800-526-5142	THIS DRAWING IS A CONTROLLED DOCUMENT FOR AMP INCORPORATED. IT IS SUBJECT TO CHANGE AND THE CONTROLLING ENGINEERING ORGANIZATION SHOULD BE CONTACTED FOR THE LATEST REVISION.	MATERIAL	FINISH	---	APPLICATION SPEC	---	---	---	---	
			- 5	- 4	WEIGHT	---	A3	00779	C-696424	---	
CUSTOMER DRAWING						SCALE	4:1	SHEET	1 OF 1	REV	A2