

W Series Heatsinks

For TO-220, TO-247, and TO-264 devices

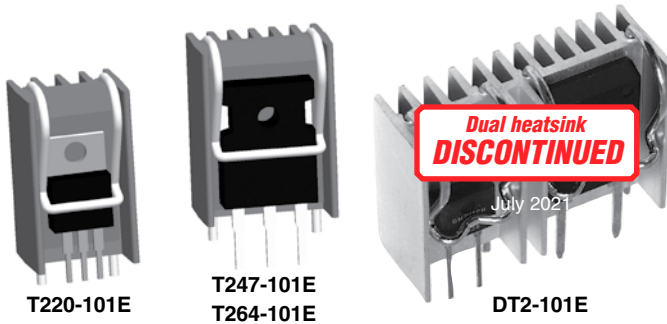

The unique design (patent pending) of the W Series heat sinks combines a tin plated, solderable, integral spring clip with an extruded aluminum heat sink body for an all-in-one solution to through-hole mounting of TO-220, TO-247, and TO-264 packages. These self-aligning heat sinks feature solderable feet and an integrated clip with 13.2 (lbf) of force on the center of the device to enhance thermal performance.

FEATURES

- Reduced Assembly Cost: spring clip and auto-align feature makes fasteners and fixtures obsolete, along with stray metal filings from tapped holes
- Maximum Repeatability: clamping force of the spring clip is not degraded by repeated loading and unloading
- Maximum Heat Transfer per Unit Space: maximum surface area per unit volume and consistent mounting force reduces thermal resistance
- Maximum Resistance to Shock and Vibration: light weight, resilient spring clip locks the component in place and is highly resistant to shock and vibration
- Maximum Reliability: helps prevent short circuits by eliminating metal particles from thread tapping
- RoHS Compliant

SERIES SPECIFICATIONS

Heatsink Part Number	For Package Type	Ohmite Resistor Series	Surface Area (in ²)	Weight	Thermal Resistance*
WA-T220-101E WV-T220-101E	TO-220	TBH25, TCH35	6.5	0.35 oz/10g	Rs-a=12°C/W Rs-a=13°C/W
WA-T247-101E WV-T247-101E	TO-247	TEH70, TEH100	8.4	0.42 oz/12g	Rs-a=11°C/W Rs-a=12°C/W
WA-T264-101E WV-T264-101E	TO-264	TFH85	8.4	0.42 oz/12g	Rs-a=11°C/W Rs-a=12°C/W
WA-DT2-101E† WV-DT2-101E†	TO-220 & TO-247	TBH25, TCH35, TEH70, TEH100	15.1	0.79 oz/22g	Rs-a=7°C/W Rs-a=8°C/W

*Natural convection at 10W heat dissipation †Discontinued

CHARACTERISTICS

Heat Sink	Aluminum alloy 6063-T5 or equivalent.
Spring Clip	Music wire, per ASTM A228
Pin	Solderable 100% tin over copper strike
Interface thermal resistance	for improvement, use thermal joint compound or 0.005 Grafoil (TGon 800 by Laird)
Interface electrical isolation	Sil-Pad 900S by Bergquist or equivalent
Mounting	Vertical thru-hole mount
Clip Force	13.2 lbf.

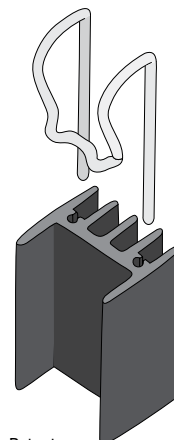

Patent Pending

(continued)

W Series Heatsinks

For TO-220, TO-247, and TO-264 devices

CHARACTERISTICS

Heat Dissipation

T220-101E, T247-101E and T264-101E

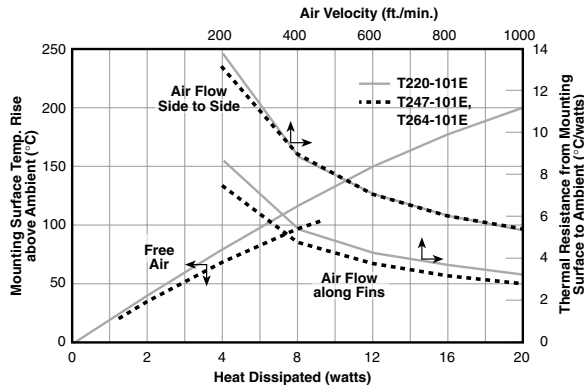

DT2-101E (discontinued)

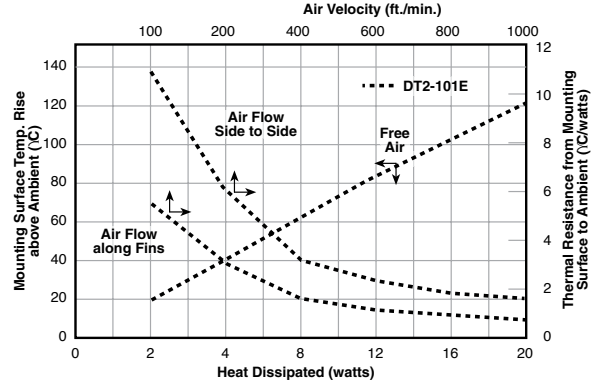

DIMENSIONS

(in./mm ±0.3mm)

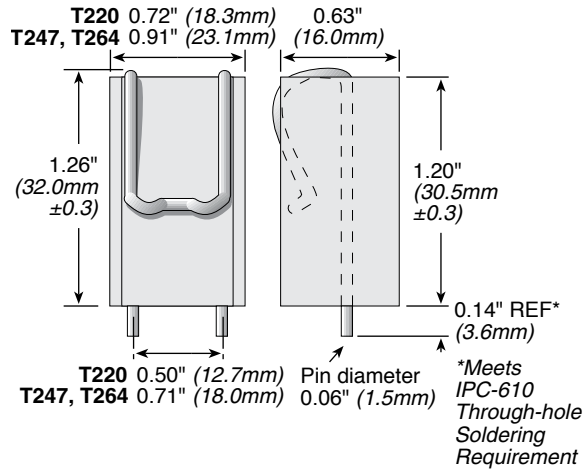

Land pattern

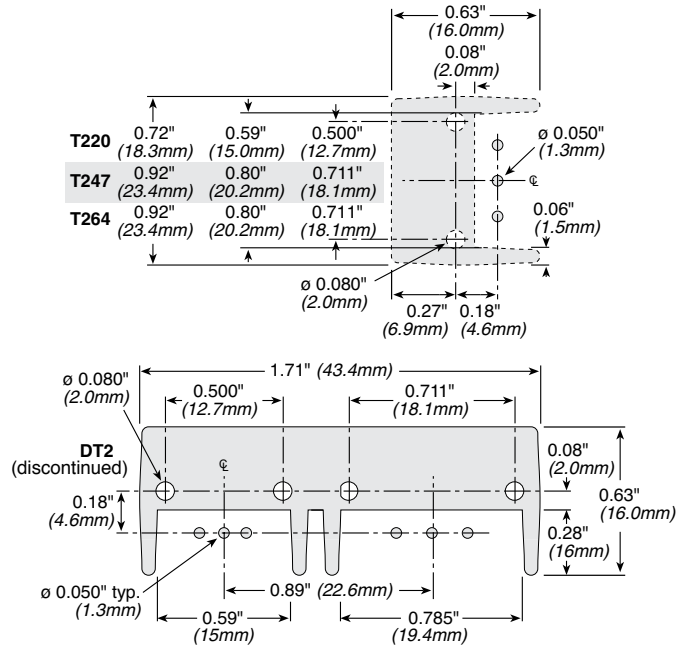

ORDERING INFORMATION

W A - T 2 2 0 - 1 0 1 E

Series	Coating	Device size	Package modifier	RoHS Compliant
	A- Black Anodized V- degreased N- Alodine 1500 Clear			

Standard part numbers

WA-T220-101E
WV-T220-101E
WA-T247-101E
WV-T247-101E
WA-T264-101E
WV-T264-101E