

PART NUMBER	REVISION	DESCRIPTION	FEED TYPE
2266266-1	E	FINE CRIMP HEIGHT ADJUST	MECHANICAL
2266266-2	E	FINE CRIMP HEIGHT ADJUST	PNEUMATIC
7-2266266-1	E	MECHANICAL AND CRIMP TOOLING KIT	MECHANICAL
7-2266266-2	E	PNEUMATIC AND CRIMP TOOLING KIT	PNEUMATIC
7-2266266-7	C	CRIMP TOOLING KIT	-

ATLANTIC VERSION TERMINATOR INTERFACE ADAPTER

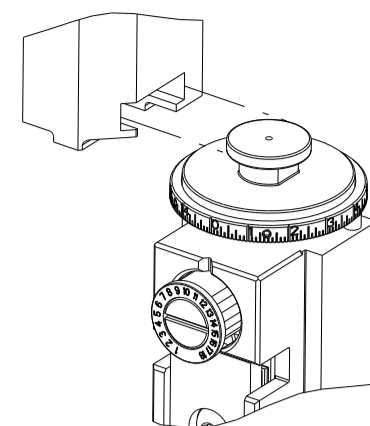

APPLICATOR DATA		
CRIMP	SIZE	TYPE
WIRE	1.96 mm [.077]	F
INSUL	2.16 mm [.085]	O

APPLICATOR INSTRUCTIONS 408-35042

TERMINAL DATA: TE TERMINAL		TE CRIMP SPECIFICATION	
TERMINAL NAME: TERMINAL, 16AWG, GET FEMALE			
WIRE STRIP LENGTH		INSULATION DIAMETER RANGE	
4.00-4.40 mm [.157-.173 IN]		2.40mm [.094 IN] MAX	
TERMINAL APPLICATION SPECIFICATION	114-13236		
TERMINALS APPLIED			
TE TERMINAL	TE TERMINAL	TE TERMINAL	TE TERMINAL
1924880-1			

WIRE SIZE	CRIMP HEIGHT mm [INCH]	CRIMP HEIGHT REFERENCE SETTING
1.50mm2	1.40+/-0.05 [.055+/- .002]	6.8

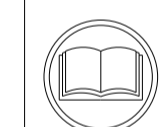

- RECOMMENDED SPARE PARTS
 - REFER TO SUPPLIED INSTRUCTION SHEET FOR CLEANING, LUBRICATION AND STORAGE OF APPLICATOR.
 - APPLY PART NUMBER 2-23419-6 LOCTITE TO THREADS OF ITEM 242.
 - CRIMP HEIGHT REFERENCE SETTING WAS THE SETTING USED WHEN THE APPLICATOR WAS QUALIFIED AT THE FACTORY. ADJUSTMENT MAY BE NECESSARY WHEN RUNNING APPLICATOR IN THE FIELD.
 - TERMINAL LUBRICANT IS RECOMMENDED.
6. UNLESS SPECIFIED OTHERWISE TORQUE VALUES SHALL BE USED PER DOCUMENT, 101-35000.

***WARNING**
ON INSTALLATION, SET WIRE DISC TO CRIMP HEIGHT REFERENCE SETTING FOR LARGEST WIRE SIZE. CRIMP HEIGHT REFERENCE SETTINGS GREATER THAN THE VALUE SHOWN MAY CAUSE DAMAGE TO THE CRIMP TOOLING. REFER TO THE INSTRUCTION SHEET FOR PROPER SETUP AND ADJUSTMENTS.

ATLANTIC VERSION
Shown on sheets 1 of 4 & 2 of 4
(Pacific version shown on sheets 3 of 4 & 4 of 4)

LOC	DIST	REVISIONS					
A	66	P	LTN	DESCRIPTION	DATE	DWN	APVD
		B		ECR-17-011397	04AUG2017	TB	TE
		C		ECR-17-016268	06NOV2017	MZ	KZ
		D		ECR-22-140065	23MAY2022	JWC	ROY
		E		ECR-22-147096	22JUL2022	FJ	TE

-	1	-	1	-	2119641-1	FEED CAM, AIR FEED	248
-	1	1	1	1	2119082-5	CAM, SNAIL, INSULATION ADJUSTMENT	244
-	1	1	1	1	2079764-1	WASHER, WAVE SPRING, CREST-TO-CREST	243
	1	1	1	1	2119083-1	RETAINER, INSULATION DIAL	242
-	1	1	1	1	7-18023-7	SCR, SKT HD CAP M3 X 4.0	241
-	-	1	-	1	2119580-1	MECHANICAL FEED ASSEMBLY	239
-	1	-	1	-	2844940-1	AIR FEED MODULE	238
-	REF	REF	REF	REF	994970-2	COUNTER, MAGNETIC	164
	1	1	1	1	2119955-1	ASSY, LUBRICATOR, SIDE FEED	113
-	1	1	1	1	2844908-1	SCREW, LOCKING	99
-	1	1	1	1	2844907-1	POST, LOCKING	98
-	1	1	1	1	455888-5	SPACER, CRIMPER	82
-	1	1	1	1	1803607-3	DOCUMENTATION PACKAGE	71
-	1	1	1	1	2119791-5	DEPRESSOR, WIRE	70
-	1	1	1	1	2119740-1	TAG, IDENTIFICATION	67
-	2	2	2	2	2168078-1	SCREW, DRIVE, RH, RoHS, 2 x .188	66
-	1	1	1	1	2168083-2	SCR, SKT HD CAP, RoHS, M4 X 8.0	60
-	1	1	1	1	5-18022-5	SCR, HEX HD CAP, M4 X 6.0	59
-	1	1	1	1	1338683-8	FEED PAWL	56
-	4	4	4	4	2168083-3	SCR, SKT HD CAP, RoHS, M4 X 12.0	54
-	2	2	2	2	1-2168083-0	SCR, SKT HD CAP, RoHS, M4 X 10	53
-	1	1	1	1	1803382-1	HOLD DOWN, SPRING LOADED	50
-	1	2	1	2	18023-9	SCR, SKT HD CAP M4 X 6.0	49
-	-	1	-	1	2119652-1	FEED CAM, PRE FEED	48
-	-	1	-	1	2119653-1	FEED CAM, POST FEED	47
-	1	1	1	1	1803583-9	APPLICATOR BASIC ASSEMBLY, SF	46
-	1	1	1	1	1803515-1	RAM ASSEMBLY, SF ATLANTIC	44
-	1	1	1	1	1803602-1	SCR, BHSC, RoHS (M8 X 25)	41
-	1	1	1	1	1-1752356-8	SUPPORT, TERMINAL	34
-	2	2	2	2	2079383-5	SCR, BHSC, RoHS (M4 X 20)	33
-	2	2	2	2	2-2844962-8	SPACER, CYLINDRICAL, STRIP GUIDE	30
-	1	1	1	1	2844992-4	ASSEMBLY, STRIP GUIDE	29
-	1	1	1	1	240792-2	DRAG, TERMINAL	25
-	1	1	1	1	1320928-2	STRIP GUIDE	24
-	1	1	1	1	2168083-2	SCR, SKT HD CAP, RoHS, M4 X 8.0	21
-	2	2	2	2	1-18028-2	WASHER, FLAT, REG M4	20
-	1	1	1	1	2119533-1	STRIPPER, SIDE FEED	19
	1	1	1	1	2119806-1	INSERT, SHEAR	13
-	1	1	1	1	3-22280-3	SPRING, COMPRESSION	12
-	1	1	1	1	1-356885-4	STOP, SHEAR	11
	1	1	1	1	2119805-1	SHEAR HOLDER, FRONT	10
	1	1	1	1	1803095-5	FLOATING SHEAR, FRONT	9
	1	2	2	1	1-1803514-6	ANVIL, COMBINATION	8
-	-	-	-	-	-	-	7
-	-	-	-	-	-	-	6
-	1	1	1	1	2119757-8	DEPRESSOR, SHEAR	5
-	1	1	1	1	3-238011-1	BLOCK, CRIMPER SPACER	4
	1	2	2	1	1-1803365-1	CRIMPER, INSULATION O	3
-	-	-	-	-	-	-	2
	1	2	2	1	4-1803470-7	CRIMPER, WIRE F	1
-	77	-72	-71	-2	-1	PART NO	DESCRIPTION
-	-	-	-	-	-	-	ITEM NO

DIMENSIONS:		TOLERANCES UNLESS OTHERWISE SPECIFIED:		DRAWING NO		RESTRICTED TO	
mm	0 PLC ±	1 PLC ±	2 PLC ±	3 PLC ±	4 PLC ±	ANGLES ±	FINISH ±
MATERIAL				WEIGHT	SCALE	SHEET	REV
Customer Accessible Production Drawing				00779	1:2	1 OF 4	E

LOC	DIST	REVISIONS					
A	66	P	LTN	DESCRIPTION	DATE	DWN	APVD
		-		SEE SHEET 1			

FEED TYPE MECHANICAL

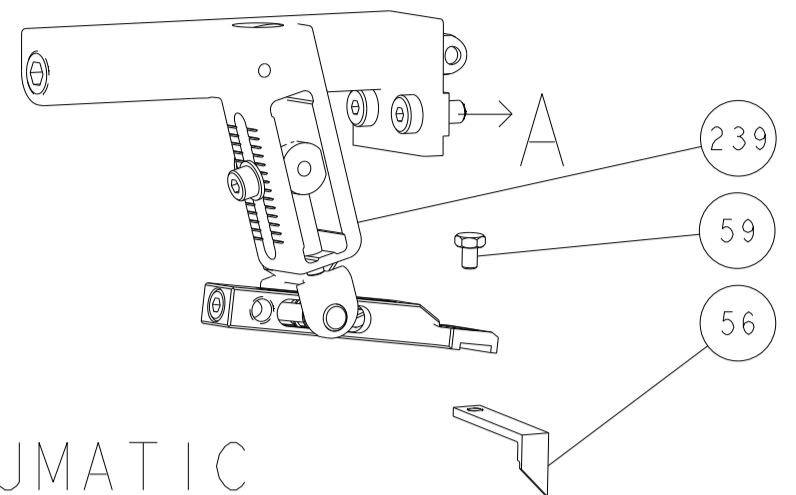

PNEUMATIC

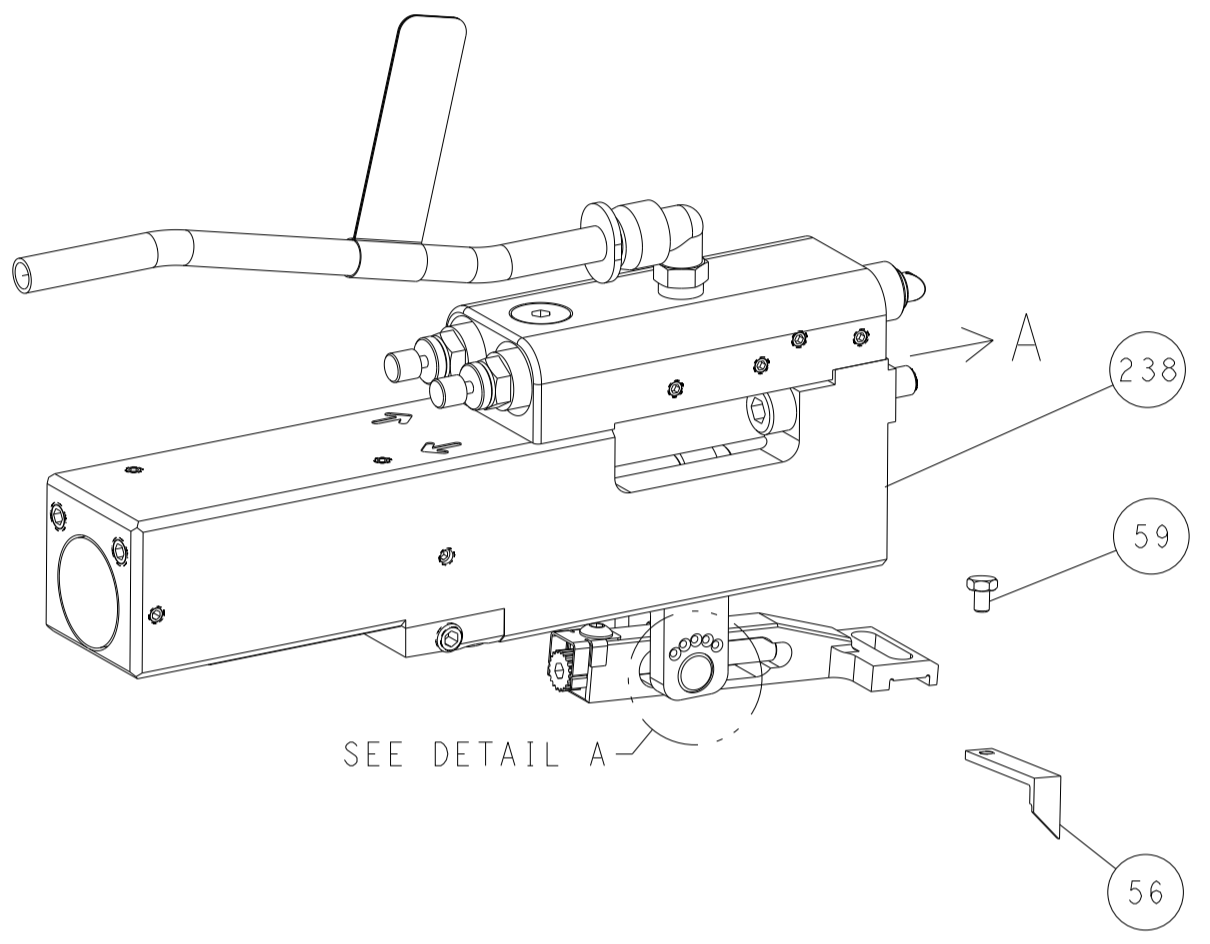

FEED SPRING SETTING POSITION (SHOWN FROM REAR SIDE)

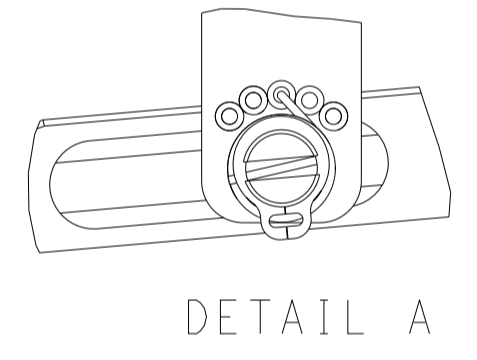

DETAIL A

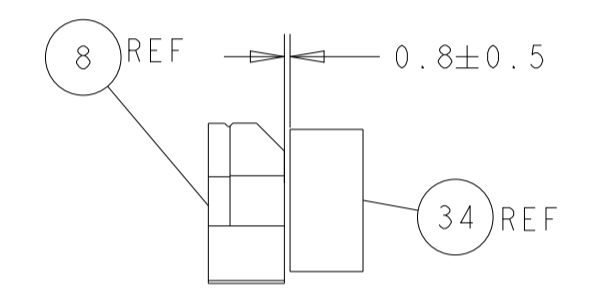
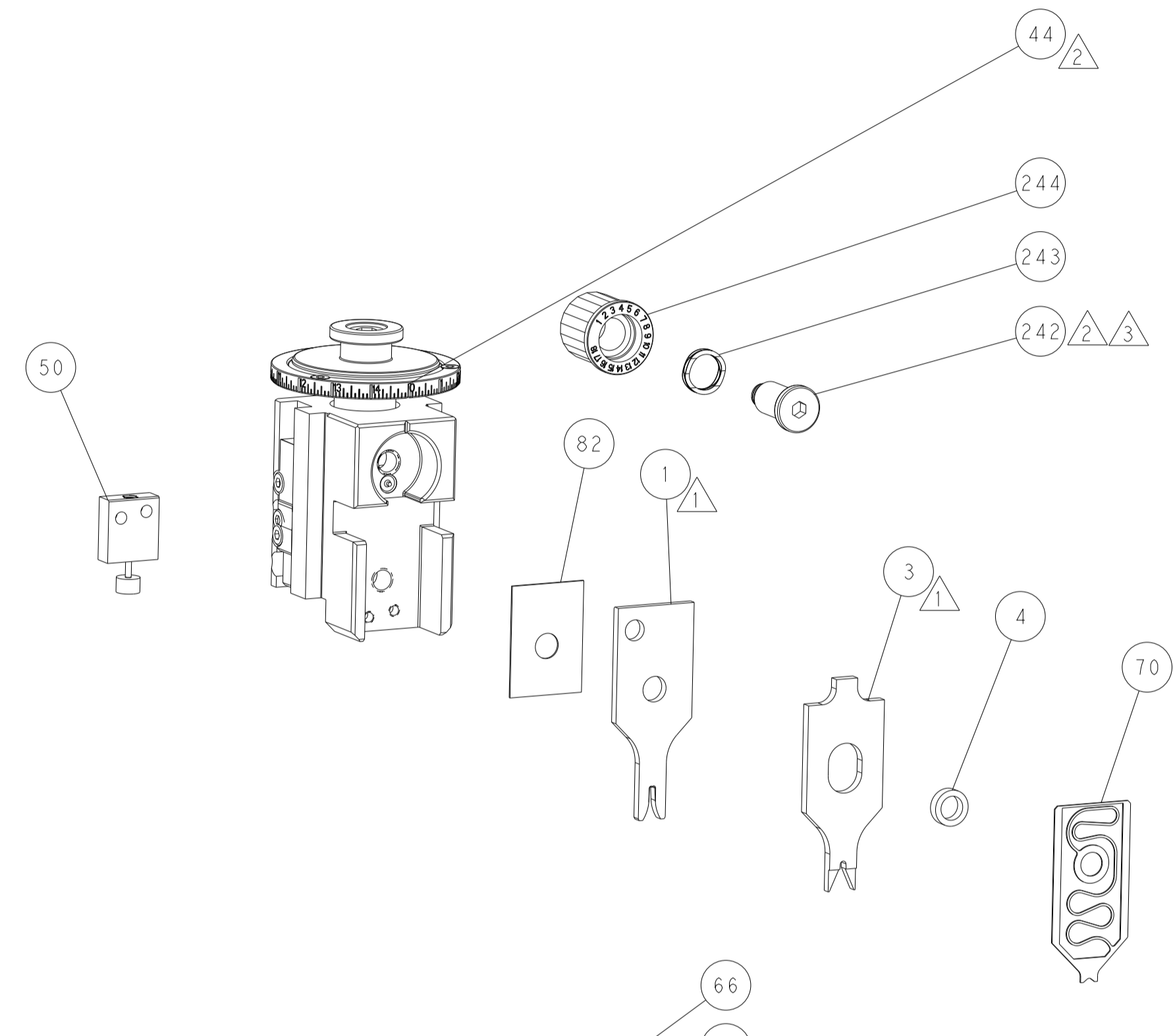
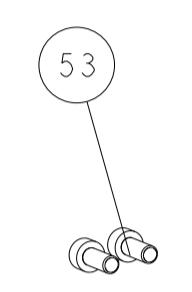

TERMINAL SUPPORT LOCATION

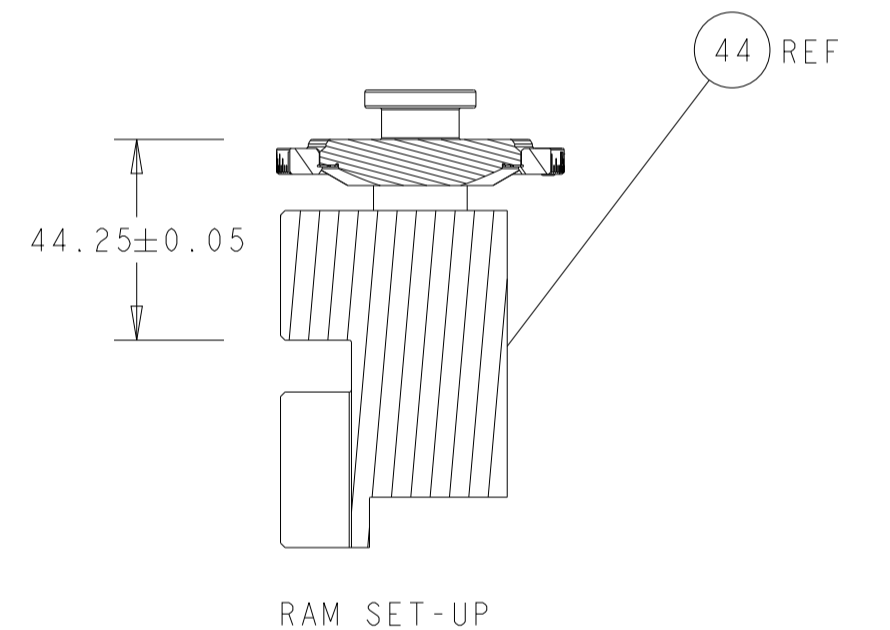

RAM SET-UP

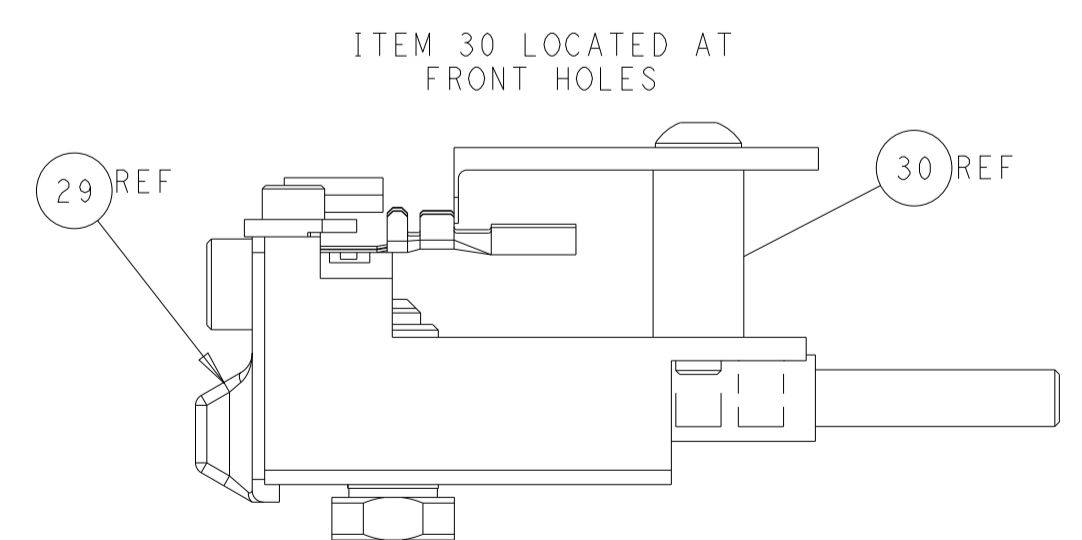

FEED TRACK POSITION GUIDE BY WIRE BARREL

CAM POSITIONS

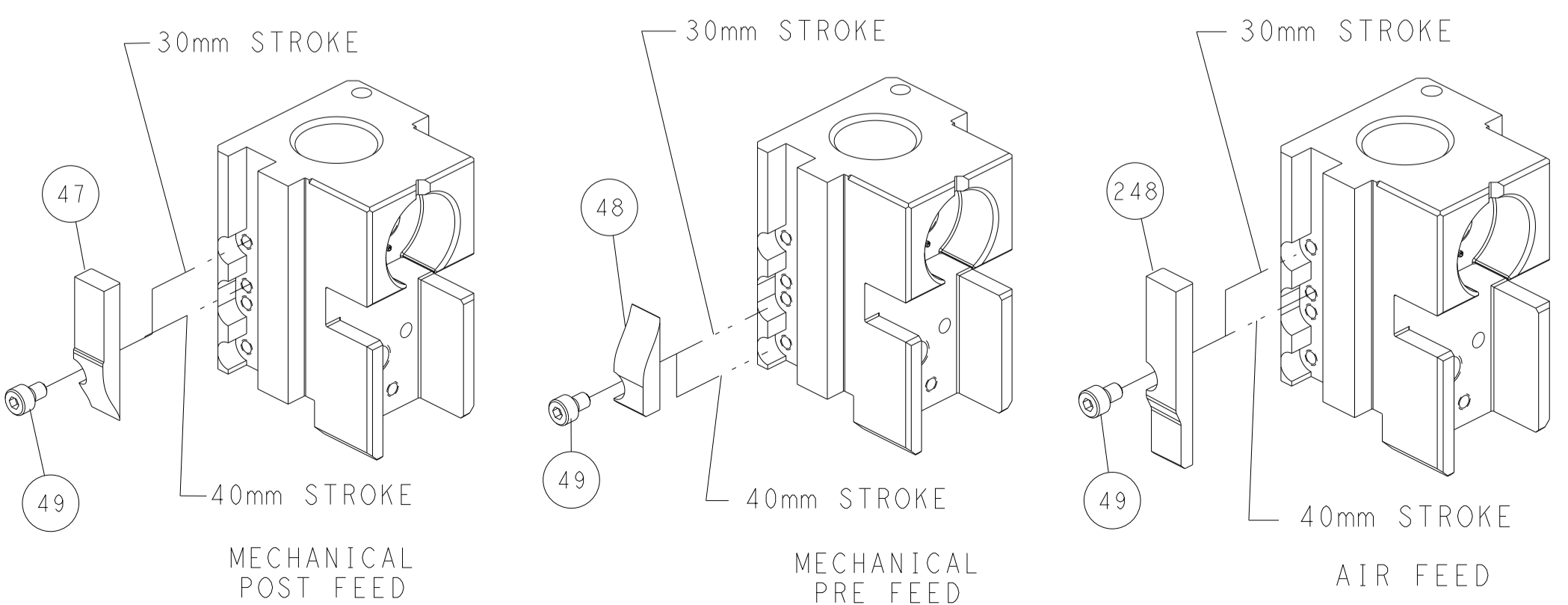

ATLANTIC VERSION
 Shown on sheets 1 of 4 & 2 of 4
 (Pacific version shown on sheets 3 of 4 & 4 of 4)

DIMENSIONS: mm 		TOLERANCES UNLESS OTHERWISE SPECIFIED: 0 PLC ± 1 PLC ± 2 PLC ± 3 PLC ± 4 PLC ± ANGLES FINISH ±		DWN X.ZHAO 14MAY2014 CHK L.ZHANG 14MAY2014 APVD T.ELBIN 14MAY2014 NAME PRODUCT SPEC APPLICATION SPEC WEIGHT Customer Accessible Production Drawing		TE Connectivity Harrisburg, PA 17105-3608 SIZE CAGE CODE DRAWING NO A1 00779 C=2266266 SCALE 1:2 SHEET 2 OF 4 REV E	
-----------------------	--	--	--	---	--	---	--

PART NUMBER	REVISION	DESCRIPTION	FEED TYPE
2-2266266-1	E	FINE CRIMP HEIGHT ADJUST	MECHANICAL
2-2266266-2	E	FINE CRIMP HEIGHT ADJUST	PNEUMATIC
7-2266266-7	C	CRIMP TOOLING KIT	-

PACIFIC VERSION TERMINATOR
INTERFACE ADAPTER

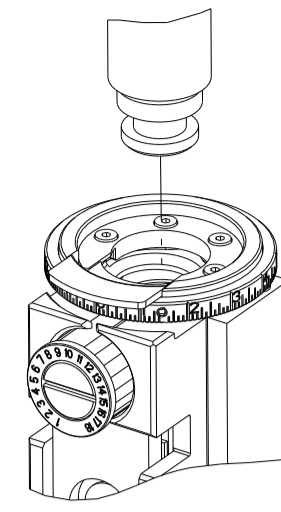

APPLICATOR DATA		
CRIMP	SIZE	TYPE
WIRE	1.96 mm [.077]	F
INSUL	2.16 mm [.085]	O

APPLICATOR INSTRUCTIONS
408-35042

TERMINAL DATA: TE TERMINAL		TE CRIMP SPECIFICATION	
TERMINAL NAME: TERMINAL, 16AWG, GET FEMALE			
WIRE STRIP LENGTH 4.00-4.40 mm [1.57-.173 IN]		INSULATION DIAMETER RANGE Ø 2.40mm [1.094 IN] MAX	
TERMINAL APPLICATION SPECIFICATION	114-13236	-	-
TERMINALS APPLIED 5			
TE TERMINAL	TE TERMINAL	TE TERMINAL	TE TERMINAL
1924880-1			

WIRE SIZE	CRIMP HEIGHT mm [INCH]	CRIMP HEIGHT REFERENCE SETTING
1.50mm ²	1.40 +/- 0.05 [1.055 +/- .002]	6.8

- 1 RECOMMENDED SPARE PARTS
- 2 REFER TO SUPPLIED INSTRUCTION SHEET FOR CLEANING, LUBRICATION AND STORAGE OF APPLICATOR.
- 3 APPLY PART NUMBER 2-23419-6 LOCTITE TO THREADS OF ITEM 242.
- 4 CRIMP HEIGHT REFERENCE SETTING WAS THE SETTING USED WHEN THE APPLICATOR WAS QUALIFIED AT THE FACTORY. ADJUSTMENT MAY BE NECESSARY WHEN RUNNING APPLICATOR IN THE FIELD.
- 5 TERMINAL LUBRICANT IS RECOMMENDED.
- 6. UNLESS SPECIFIED OTHERWISE TORQUE VALUES SHALL BE USED PER DOCUMENT, 101-35000.

***WARNING**
ON INSTALLATION, SET WIRE DISC TO CRIMP HEIGHT REFERENCE SETTING FOR LARGEST WIRE SIZE. CRIMP HEIGHT REFERENCE SETTINGS GREATER THAN THE VALUE SHOWN MAY CAUSE DAMAGE TO THE CRIMP TOOLING. REFER TO THE INSTRUCTION SHEET FOR PROPER SETUP AND ADJUSTMENTS.

PACIFIC VERSION
Shown on sheets 3 of 4 & 4 of 4
(Atlantic version shown on sheets 1 of 4 & 2 of 4)

LOC	DIST	REVISIONS					
A	66	P	LTN	DESCRIPTION	DATE	OWN	APVD
-	-	-	-	SEE SHEET 1	-	-	-

-	1	1	2119082-5	CAM, SNAIL, INSULATION ADJUSTMENT	244
-	1	1	2079764-1	WASHER, WAVE SPRING, CREST-TO-CREST	243
-	1	1	2119083-1	RETAINER, INSULATION DIAL	242
-	1	1	7-18023-7	SCR, SKT HD CAP M3 X 4.0	241
-	-	1	2119580-1	MECHANICAL FEED ASSEMBLY	239
-	1	-	2844940-1	AIR FEED MODULE	238
-	REF	REF	994970-2	COUNTER, MAGNETIC	164
-	1	1	2119641-2	FEED CAM, AIR FEED	151
-	1	1	2168083-8	SCR, SKT HD CAP, RoHS, M4 X 16	144
-	4	4	2168083-9	SCR, SKT HD CAP, RoHS, M4 X 20	143
-	-	1	2119653-2	FEED CAM, POST FEED	142
-	1	1	1-1803583-0	APPLICATOR BASIC ASSEMBLY, SF	141
-	1	1	1803516-1	RAM ASSEMBLY, SF PACIFIC	140
-	1	1	2119955-1	ASSY, LUBRICATOR, SIDE FEED	113
-	1	1	2844908-1	SCREW, LOCKING	99
-	1	1	2844907-1	POST, LOCKING	98
-	1	1	455888-5	SPACER, CRIMPER	82
-	1	1	1803607-3	DOCUMENTATION PACKAGE	71
-	1	1	2119791-5	DEPRESSOR, WIRE	70
-	1	1	2119740-1	TAG, IDENTIFICATION	67
-	2	2	2168078-1	SCREW, DRIVE, RH, RoHS, 2 x .188	66
-	1	1	5-18022-5	SCR, HEX HD CAP, M4 X 6.0	59
-	1	1	1338683-8	FEED PAWL	56
-	2	2	1-2168083-0	SCR, SKT HD CAP, RoHS, M4 X 10	53
-	1	1	1803382-1	HOLD DOWN, SPRING LOADED	50
-	1	2	18023-9	SCR, SKT HD CAP M4 X 6.0	49
-	-	1	2119652-1	FEED CAM, PRE FEED	48
-	1	1	1803602-1	SCR, BHSC, RoHS (M8 X 25)	41
-	1	1	1-1752356-8	SUPPORT, TERMINAL	34
-	2	2	2079383-5	SCR, BHSC, RoHS (M4 X 20)	33
-	2	2	2-2844962-8	SPACER, CYLINDRICAL, STRIP GUIDE	30
-	1	1	2844992-4	ASSEMBLY, STRIP GUIDE	29
-	1	1	240792-2	DRAG, TERMINAL	25
-	1	1	1320928-2	STRIP GUIDE	24
-	1	1	2168083-2	SCR, SKT HD CAP, RoHS, M4 X 8.0	21
-	2	2	1-18028-2	WASHER, FLAT, REG M4	20
-	1	1	2119533-1	STRIPPER, SIDE FEED	19
-	1	1	2119806-1	INSERT, SHEAR	13
-	1	1	3-22280-3	SPRING, COMPRESSION	12
-	1	1	1-356885-4	STOP, SHEAR	11
-	1	1	2119805-1	SHEAR HOLDER, FRONT	10
-	1	1	1803095-5	FLOATING SHEAR, FRONT	9
-	1	1	1-1803514-6	ANVIL, COMBINATION	8
-	-	-	-	-	7
-	-	-	-	-	6
-	1	1	2119757-8	DEPRESSOR, SHEAR	5
-	1	1	3-238011-1	BLOCK, CRIMPER SPACER	4
-	1	1	1-1803365-1	CRIMPER, INSULATION O	3
-	-	-	-	-	2
-	1	1	4-1803470-7	CRIMPER, WIRE F	1
-77	-22	-21	PART NO	DESCRIPTION	ITEM NO

DIMENSIONS:		TOLERANCES UNLESS OTHERWISE SPECIFIED:		DWG: X.ZHAO 14MAY2014		CHK: L.ZHANG 14MAY2014		APVD: T.ELBIN 14MAY2014		NAME: Ocean Side Feed Applicator	
mm	0 PLC ±	1 PLC ±	2 PLC ±	3 PLC ±	4 PLC ±	ANGLES ±	FINISH	SIZE: A1	CAGE CODE: 00779	DRAWING NO: C=2266266	RESTRICTED TO: -
MATERIAL: -		FINISH: -		WEIGHT: -		SCALE: 1:2		SHEET: 3 OF 4		REV: E	

LOC		DIST		REVISIONS			
A	66	P	LTM	DESCRIPTION	DATE	DWN	APVD
		-		SEE SHEET 1			

FEED TYPE MECHANICAL

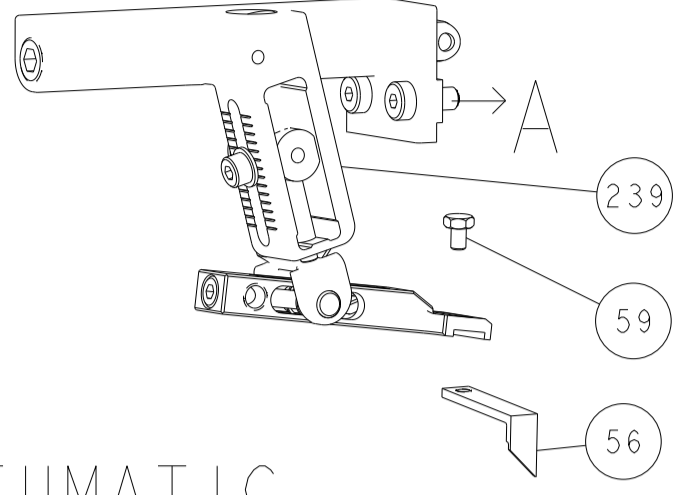

PNEUMATIC

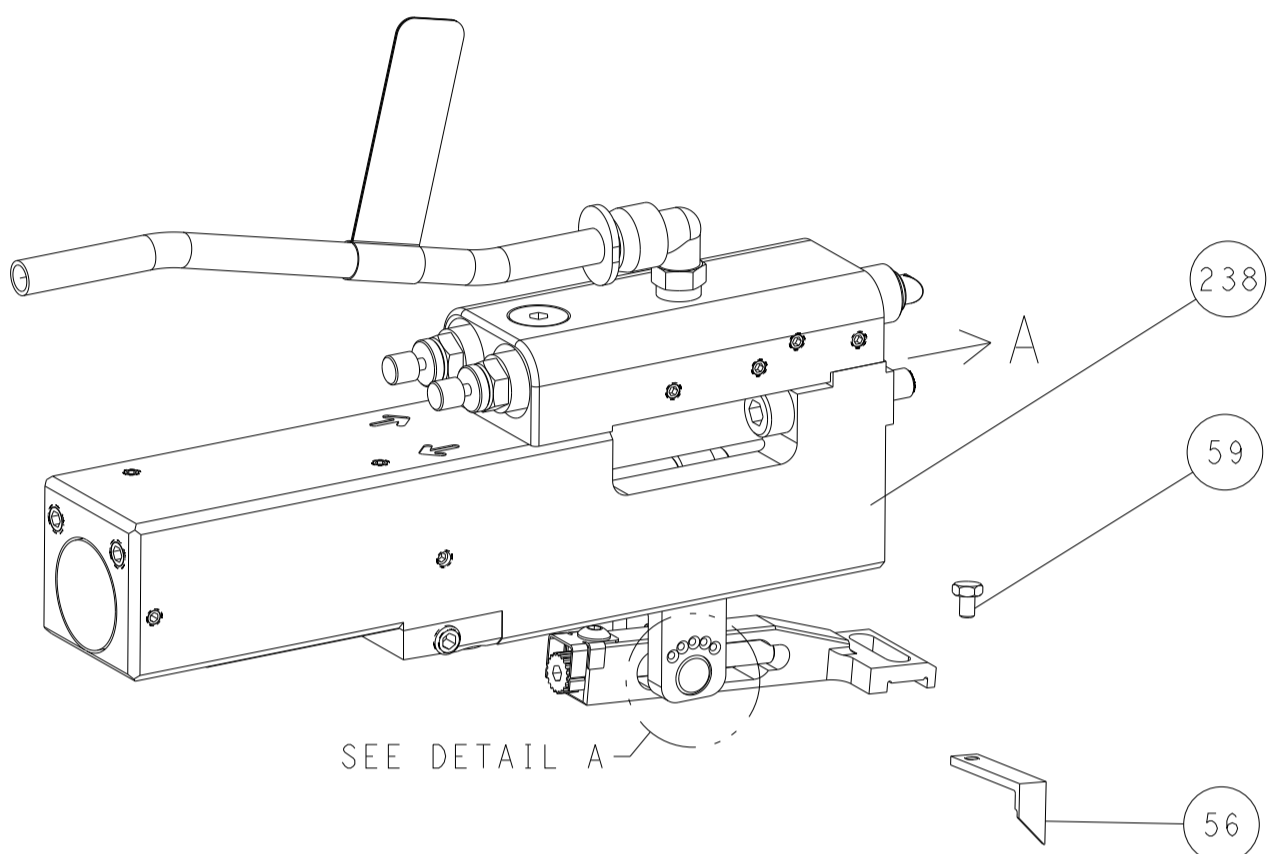

FEED SPRING SETTING POSITION (SHOWN FROM REAR SIDE)

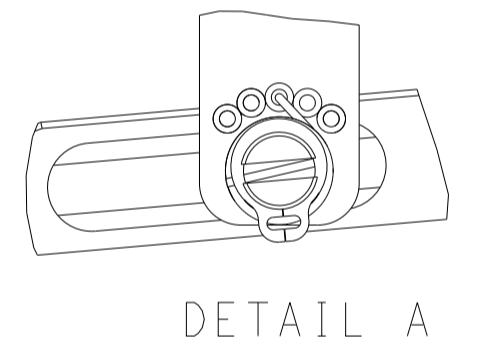

DETAIL A

CAM POSITIONS

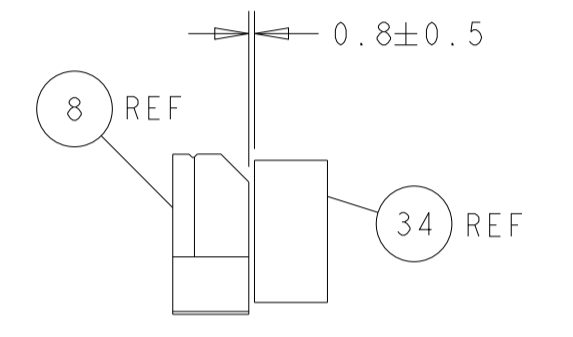
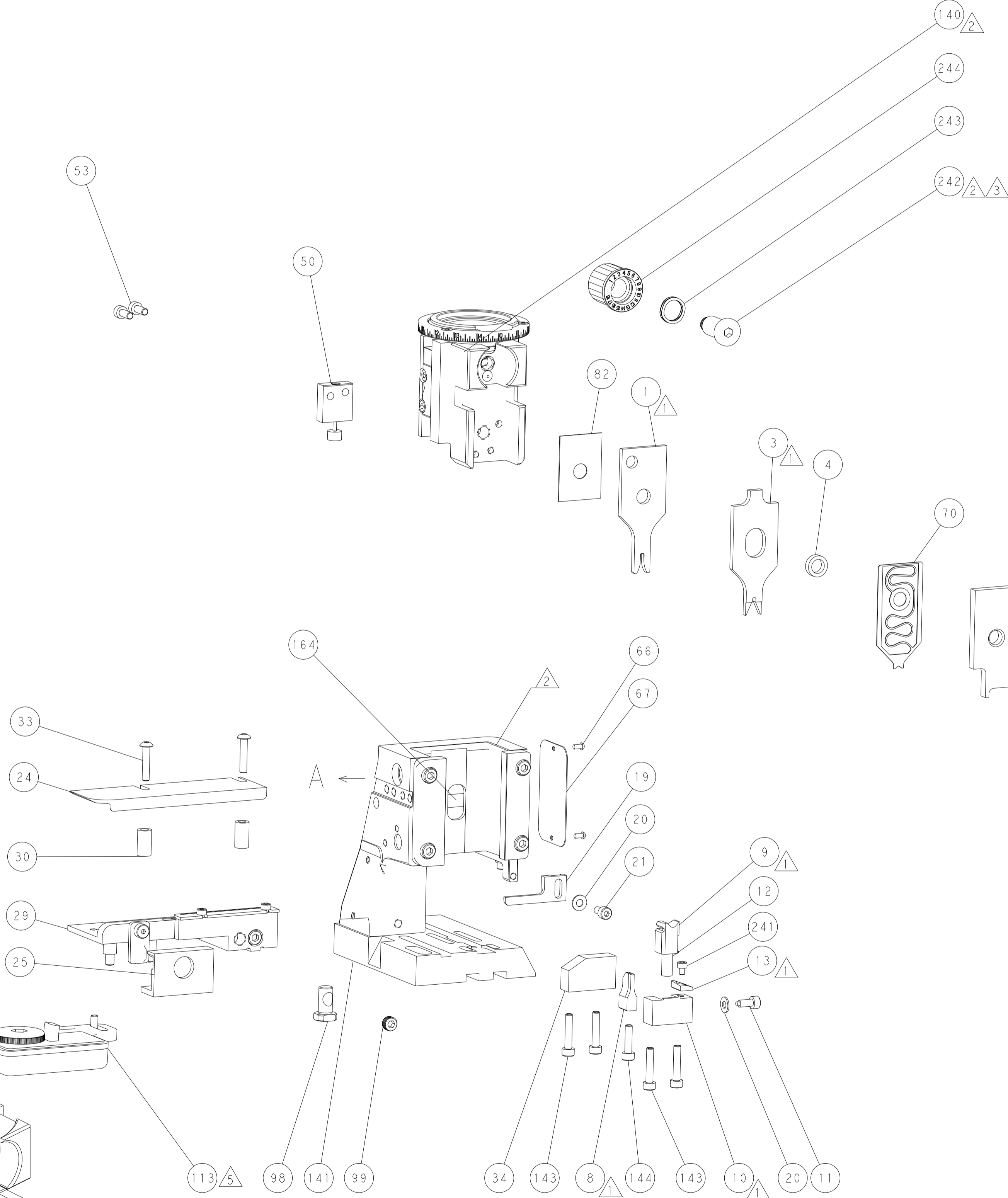
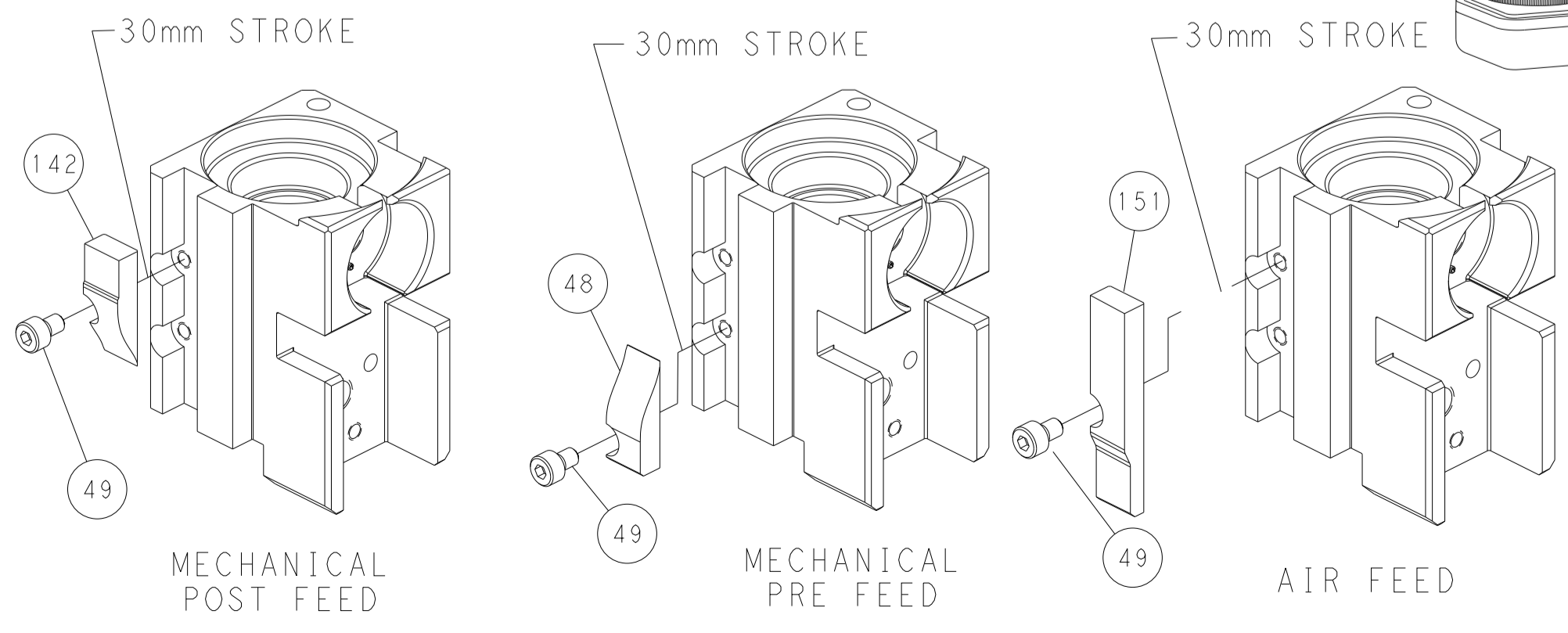

TERMINAL SUPPORT LOCATION

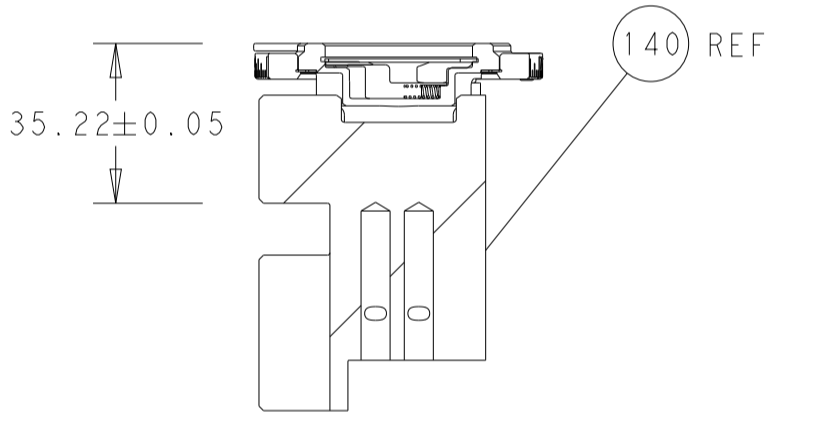

RAM SET-UP

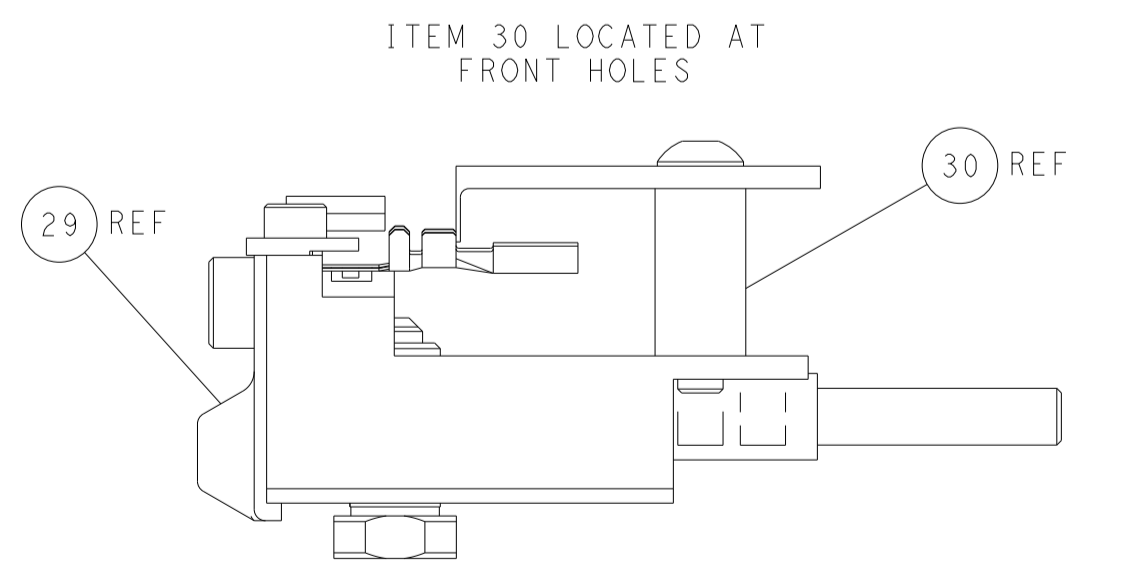

FEED TRACK POSITION GUIDE BY WIRE BARREL

PACIFIC VERSION
 Shown on sheets 3 of 4 & 4 of 4
 (Atlantic version shown on sheets 1 of 4 & 2 of 4)

<small>THIS DRAWING IS UNPUBLISHED. RELEASED FOR PUBLICATION. ALL RIGHTS RESERVED. © 2014 BY TYCO ELECTRONICS CORPORATION. THIS DRAWING IS THE PROPERTY OF TYCO ELECTRONICS CORPORATION. IT IS TO BE USED ONLY FOR THE PURPOSES AND IN THE QUANTITIES SPECIFIED IN THE ORDER. ANY OTHER USE IS STRICTLY PROHIBITED. CONTACT TYCO ELECTRONICS CORPORATION FOR MORE INFORMATION.</small>		DWN: X. ZHAO 14MAY2014 CHK: L. ZHANG 14MAY2014 APVD: T. ELBIN 14MAY2014	TE Connectivity Harrisburg, PA 17105-3608
DIMENSIONS: mm TOLERANCES UNLESS OTHERWISE SPECIFIED: 0 PLC ± 1 PLC ± 2 PLC ± 3 PLC ± 4 PLC ± ANGLES FINISH ±		NAME: Ocean Side Feed Applier APPLICATION SPEC: - SIZE: A1 CAGE CODE: 00779 DRAWING NO: C-2266266	RESTRICTED TO: - SCALE: 1:2 SHEET: 4 OF 4 REV: E
MATERIAL: - FINISH: -		WEIGHT: - Customer Accessible Production Drawing	SHEETS 1 & 2 ARE NOT REQUIRED FOR PACIFIC VERSION