

Large Current External FET Controller Type Switching Regulator

# Step-down, High-efficiency Switching Regulators (Controller type)

BD9011EKN , BD9011KV , BD9775FV



## ■ BD9011EKN, BD9011KV

### ● Overview

The BD9011EKN/KV is a 2-ch synchronous controller with rectification switching for enhanced power management efficiency. It supports a wide input range, enabling low power consumption ecodeign for an array of electronics.

### ● Features

- 1) Wide input voltage range: 3.9V to 30V
- 2) Precision voltage references:  $0.8V \pm 1\%$
- 3) FET direct drive
- 4) Rectification switching for increased efficiency
- 5) Variable frequency: 250k to 550kHz (external synchronization to 550kHz)
- 6) Built-in selected OFF latch and auto remove over current protection
- 7) Built-in independent power up/power down sequencing control
- 8) Make various application , step-down , step-up and step-up-down
- 9) Small footprint packages: HQFN36V, VQFP48C

### ● Applications

Car audio and navigation systems, CRTTV, LCDTV, PDPTV, STB, DVD, and PC systems, portable CD and DVD players, etc.

### ● Absolute Maximum Ratings (Ta=25°C)

Parameter	Symbol	Rating	Unit	Parameter	Symbol	Rating	Unit
EXTVCC Voltage	EXTVCC	34 <sup>*1</sup>	V	COMP1,2 Voltage	COMP1,2	VREG5	V
VCCCL1,2 Voltage	VCCCL1,2	34 <sup>*1</sup>	V	DET1,2 Voltage	DET1,2		
CL1,2 Voltage	CL1,2	34	V	RT, SYNC Voltage	RT, SYNC		
SW1,2 Voltage	SW1,2	34 <sup>*1</sup>	V	Power Dissipation	Pd	0.875 <sup>*2</sup>	W
BOOT1,2 Voltage	BOOT1,2	40 <sup>*1</sup>	V			1.1 <sup>*2</sup>	W
BOOT1,2-SW1,2 Voltage	BOOT1,2-SW1,2	7 <sup>*1</sup>	V			(VQFP48C)	
STB, EN1,2 Voltage	STB, EN1,2	VCC	V	Operating temperature	Topr	-40 to +105	°C
VREG5,5A	VREG5,5A	7	V	Storage temperature	Tstg	-55 to +150	°C
VREG33	VREG33	VREG5	V	Junction temperature	Tj	+150	°C
SS1,2, FB1,2	SS1,2, FB1,2	VREG5	V				

\*1 Regardless of the listed rating, do not exceed Pd in any circumstances.

\*2 Mounted on a 70mm x 70mm x 0.8mm glass-epoxy board. De-rated at 7.44mW/°C (HQFN36V) or 8.8mW/°C (VQFP48C) above 25°C.

●Operating conditions (Ta=25°C)

Parameter	Symbol	Min.	Typ.	Max.	Unit
Input voltage 1	EXTVCC	3.9 <sup>*1 *2</sup>	12	30	V
Input voltage 2	VCC	3.9 <sup>*1 *2</sup>	12	30	V
BOOT – SW voltage	BOOT – SW	4.5	5	VREG5	V
Carrier frequency	OSC	250	300	550	kHz
Synchronous frequency	SYNC	OSC	-	550	kHz
Synchronous pulse duty	Duty	40	50	60	%
Min OFF pulse	TMIN	-	100	-	nsec

★This product is not designed to provide resistance against radiation.

\*1 After more than 4.5V, voltage range.

\*2 In case of using less than 6V, Short to VCC, EXTVCC and VREG5.

●Electrical characteristics (Unless otherwise specified, Ta=25°C VCC=12V STB=5V EN1,2=5V)

Parameter	Symbol	Limit			Unit	Conditions
		Min.	Typ.	Max.		
VIN bias current	IIN	-	5	10	mA	
Shutdown mode current	IST	-	0	10	μA	VSTB=0V
[Error Amp Block]						
Feedback reference voltage	VOB	0.792	0.800	0.808	V	
Feedback reference voltage (Ta=-40 to 105°C)	VOB+	0.784	0.800	0.816	V	Ta=-40 to 105°C ※
Open circuit voltage gain	Averr	-	46	-	dB	
VO input bias current	IVo+	-	-	1	μA	
[FET Driver Block]						
HG high side ON resistance	HGhon	-	1.5	-	Ω	
HG low side ON resistance	HGlon	-	1.0	-	Ω	
LG high side ON resistance	LGhon	-	1.5	-	Ω	
LG low side ON resistance	LGlon	-	0.5	-	Ω	
[Oscillator]						
Carrier frequency	FOSC	270	300	330	kHz	RT=100 kΩ
Synchronous frequency	Fsync	-	500	-	kHz	RT=100 kΩ, SYNC=500kHz
[Over Current Protection Block]						
CL threshold voltage	Vswth	70	90	110	mV	
CL threshold voltage (Ta=-40 to 105°C)	Vswth+	67	90	113	mV	Ta=-40 to 105°C ※
[VREG Block]						
VREG5 output voltage	VREG5	4.8	5	5.2	V	IREF=6mA
VREG33 reference voltage	VREG33	3.0	3.3	3.6	V	IREF=6mA
VREG5 threshold voltage	VREG_UVLO	2.6	2.8	3.0	V	VREG:Sweep down
VREG5 hysteresis voltage	DVREG_UVLO	50	100	200	mV	VREG:Sweep up
[Soft start block]						
Charge current	ISS	6.5	10	13.5	μA	VSS=1V
Charge current (Ta=-40 to 105°C)	ISS+	6	10	14	μA	VSS=1V, Ta=-40 to 105°C ※

Note: Not all shipped products are subject to outgoing inspection.

●Reference data (Unless otherwise specified, Ta=25°C)

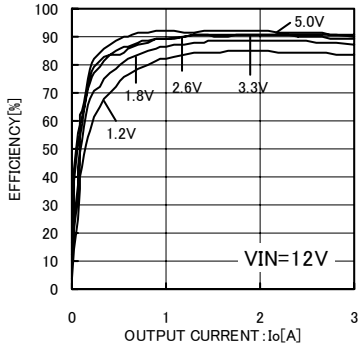

Fig.1 Efficiency 1

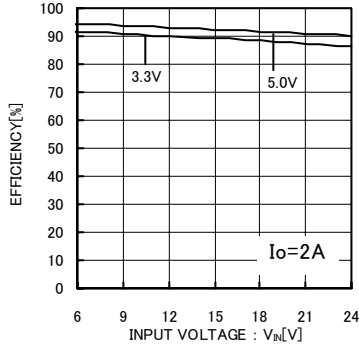

Fig.2 Efficiency 2

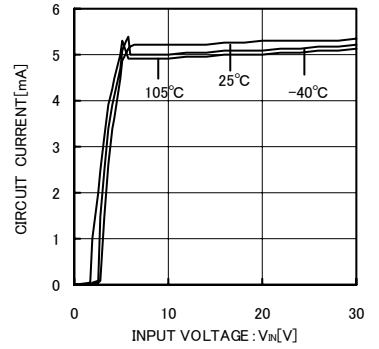

Fig.3 Circuit current

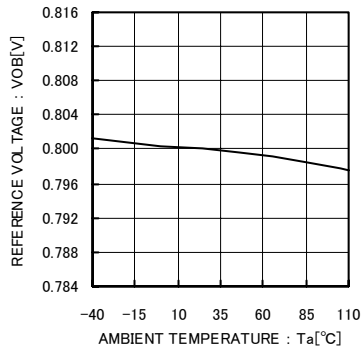

Fig.4 Reference voltage vs. temperature characteristics

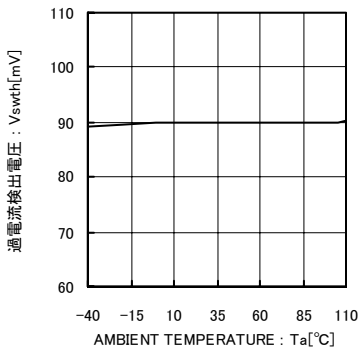

Fig.5 Over current detection vs. temperature characteristics

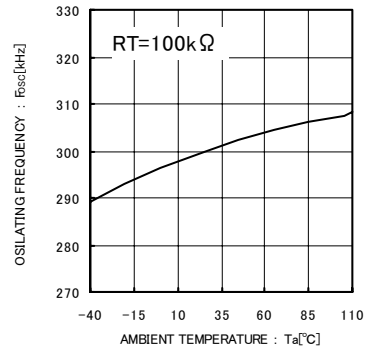

Fig.6 Frequency vs. temperature characteristics

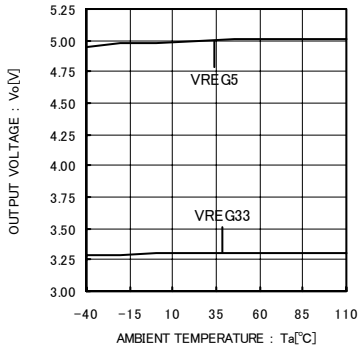

Fig.7 Internal Reg vs. temperature characteristics

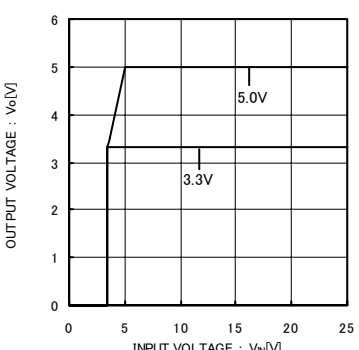

Fig.8 Line regulation

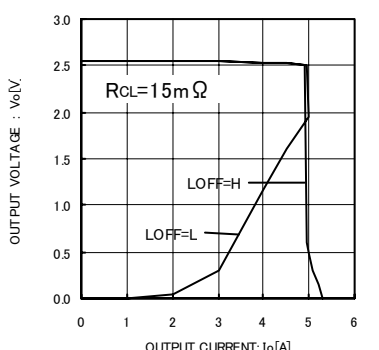

Fig.9 Load regulation

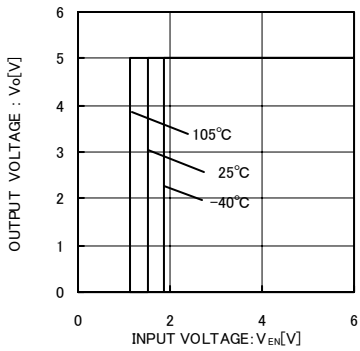

Fig.10 EN threshold voltage

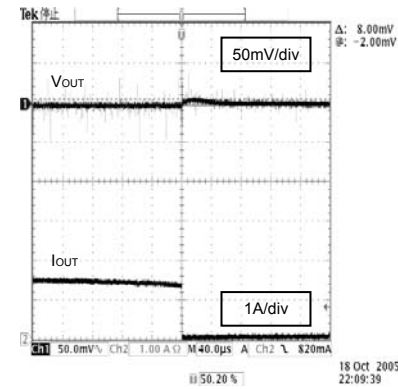

Fig.11 Load transient response 1

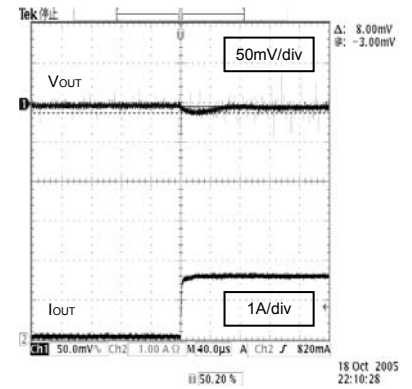

Fig.12 Load transient response 2

●Block diagram (Parentheses indicate VQFP48C pin numbers)

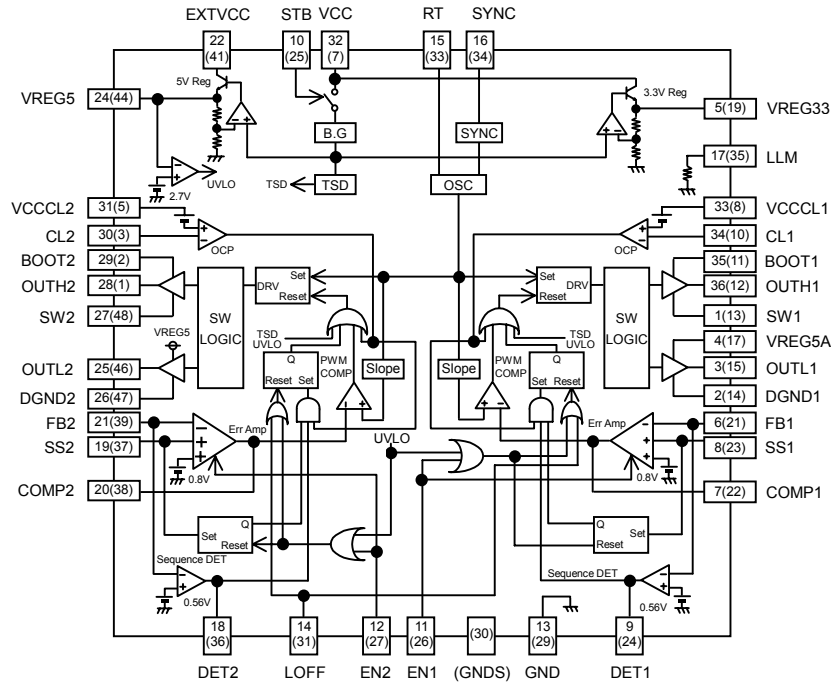

Fig-13

●Pin configuration

BD9011EKN (HQN36V)

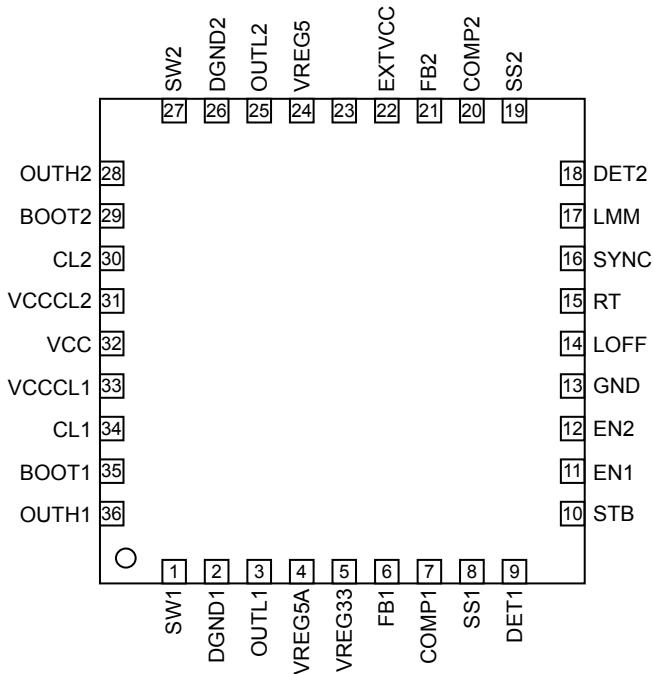

Fig-14

●PIN function table

Pin No.	Pin name	Function
1	SW1	High side FET source pin 1
2	DGND1	Low side FET source pin 1
3	OUTL1	Low side FET gate drive pin 1
4	VREG5A	FET drive REG input
5	VREG33	Reference input REG output
6	FB1	Error amp input 1
7	COMP1	Error amp output 1
8	SS1	Soft start setting pin 1
9	DET1	FB detector output 1
10	STB	Standby ON/OFF pin
11	EN1	Output 1ON/OFF pin
12	EN2	Output 2ON/OFF pin
13	GND	Ground
14	LOFF	Over current protection OFF latch function ON/OFF pin
15	RT	Switching frequency setting pin
16	SYNC	External synchronous pulse input pin
17	LLM	Built-in pull-down resistor pin
18	DET2	FB detector output 2
19	SS2	Soft start setting pin 2
20	COMP2	Error amp output 2
21	FB2	Error amp input 2
22	EXTVCC	External power input pin
23	—	N.C.
24	VREG5	FET drive REG output
25	OUTL2	Low side FET gate drive pin 2
26	DGND2	Low side FET source pin 2
27	SW2	High side FET source pin 2
28	OUTH2	Hi side FET gate drive pin 2
29	BOOT2	OUTH2 driver power pin
30	CL2	Over current detector setting pin 2
31	VCCCL2	Over current detection VCC2
32	VCC	Input power pin
33	VCCCL1	Over current detection VCC1
34	CL1	Over current detector setting pin 1
35	BOOT1	OUTH1 driver power pin
36	OUTH1	High side FET gate drive pin 1

● Pin configuration

BD9011KV (VQFP48C)

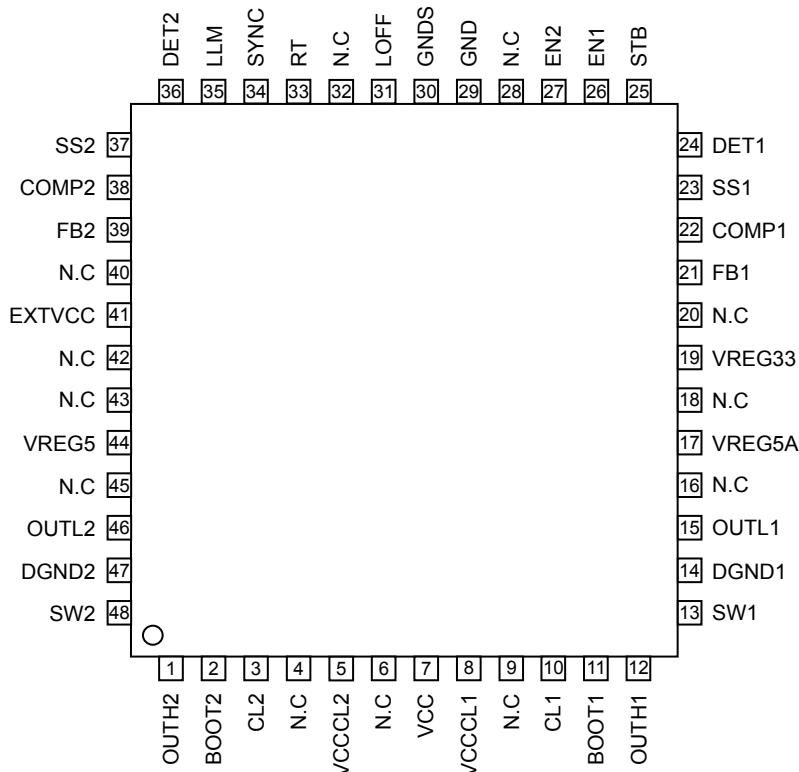

Fig-15

● Pin function table

Pin No.	Pin name	Function
1	OUTH2	High side FET gate drive pin 2
2	BOOT2	OUTH2 driver power pin
3	CL2	Over current detection pin 2
4	N.C	Non-connect (unused) pin
5	VCCCL2	Over current detection VCC2
6	N.C	Non-connect (unused) pin
7	VCC	Input power pin
8	VCCCL1	Over current detection CC1
9	N.C	Non-connect (unused) pin
10	CL1	Over current detection setting pin 1
11	BOOT1	OUTH1 driver power pin
12	OUTH1	High side FET gate drive pin 1
13	SW1	High side FET source pin 1
14	DGND1	Low side FET source pin 1
15	OUTL1	Low side FET gate drive pin 1
16	N.C	Non-connect (unused) pin
17	VREG5A	FET drive REG input
18	N.C	Non-connect (unused) pin
19	VREG33	Reference input REG output
20	N.C	Non-connect (unused) pin
21	FB1	Error amp input 1
22	COMP1	Error amp output 1
23	SS1	Soft start setting pin 1
24	DET1	FB detector output 1
25	STB	Standby ON/OFF pin
26	EN1	Output 1 ON/OFF pin
27	EN2	Output 2 ON/OFF pin
28	N.C	Non-connect (unused) pin
29	GND	Ground
30	GNDS	Sense ground
31	LOFF	Over current protection OFF latch function ON/OFF pin
32	N.C	Non-connect (unused) pin
33	RT	Switching frequency setting pin
34	SYNC	External synchronous pulse input pin
35	LLM	Built-in pull-down resistor pin
36	DET2	FB detector output 2
37	SS2	Soft start setting pin 2
38	COMP2	Error amp output 2
39	FB2	Error amp input 2
40	N.C	Non-connect (unused) pin
41	EXTVCC	External power input pin
42	N.C	Non-connect (unused) pin
43	N.C	Non-connect (unused) pin
44	VREG5	FET drive REG output
45	N.C	Non-connect (unused) pin
46	OUTL2	Low side FET gate drive pin 2
47	DGND2	Low side FET source pin 2
48	SW2	High side FET source pin 2

● Block functional descriptions

- Error amp  
The error amp compares output feedback voltage to the 0.8V reference voltage and provides the comparison result as COMP voltage, which is used to determine the switching Duty. COMP voltage is limited to the SS voltage, since soft start at power up is based on SS pin voltage.
- Oscillator (OSC)  
Oscillation frequency is determined by the switching frequency pin (RT) in this block. The frequency can be set between 250kHz and 550kHz.
- SLOPE  
The SLOPE block uses the clock produced by the oscillator to generate a triangular wave, and sends the wave to the PWM comparator.
- PWM COMP  
The PWM comparator determines switching Duty by comparing the COMP voltage, output from the error amp, with the triangular wave from the SLOPE block. Switching duty is limited to a percentage of the internal maximum duty, and thus cannot be 100% of the maximum.
- Reference voltage (5Vreg, 3.3Vreg)  
This block generates the internal reference voltages: 5V and 3.3V.
- External synchronization (SYNC)  
Determines the switching frequency, based on the external pulse applied.
- Over current protection (OCP)  
Over current protection is activated when the VCCCL-CL voltage reaches or exceeds 90mV. When over current protection is active, Duty is low, and output voltage also decreases. When LOFF=L, the output voltage has fallen to 70% or below and output is latched OFF. The OFF latch mode ends when the latch is set to STB, EN.
- Sequence control (Sequence DET)  
Compares FB voltage with reference voltage (0.56V) and outputs the result as DET.
- Protection circuits (UVLO/TSD)  
The UVLO lock out function is activated when VREG falls to about 2.8V, while TSD turns outputs OFF when the chip temperature reaches or exceeds 150°C. Output is restored when temperature falls back below the threshold value.

● Application circuit example (Parentheses indicate VQFP48C pin numbers)

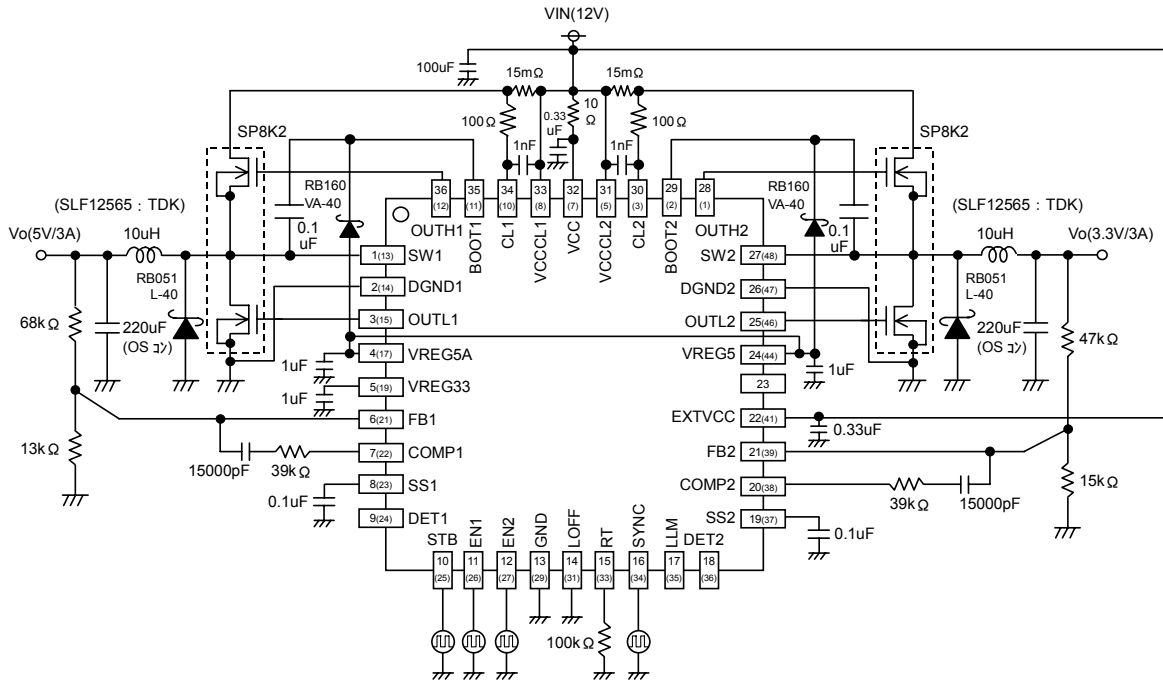

Fig-16A (Step-Down : Cout=OS Capacitor)

There are many factors(The PCB board layout, Output Current, etc.)that can affect the DCDC characteristics. Please verify and confirm using practical applications.

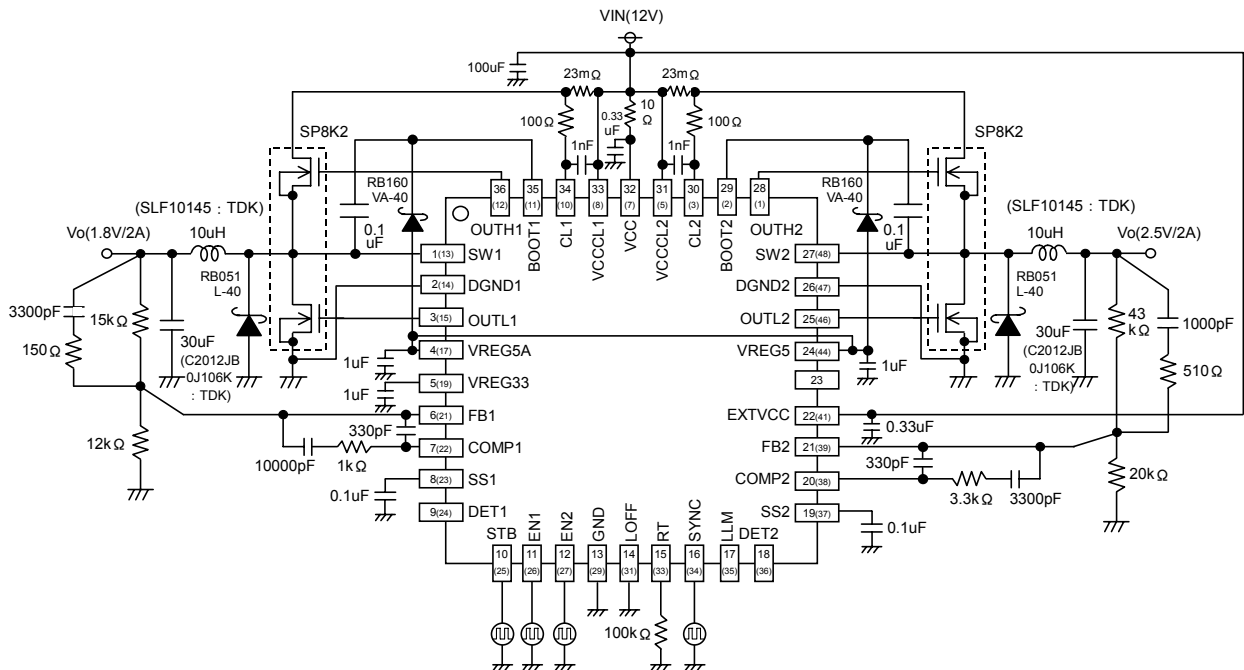

Fig-16B (Step-Down : Cout=Ceramic Capacitor)

There are many factors(The PCB board layout, Output Current, etc.)that can affect the DCDC characteristics. Please verify and confirm using practical applications.

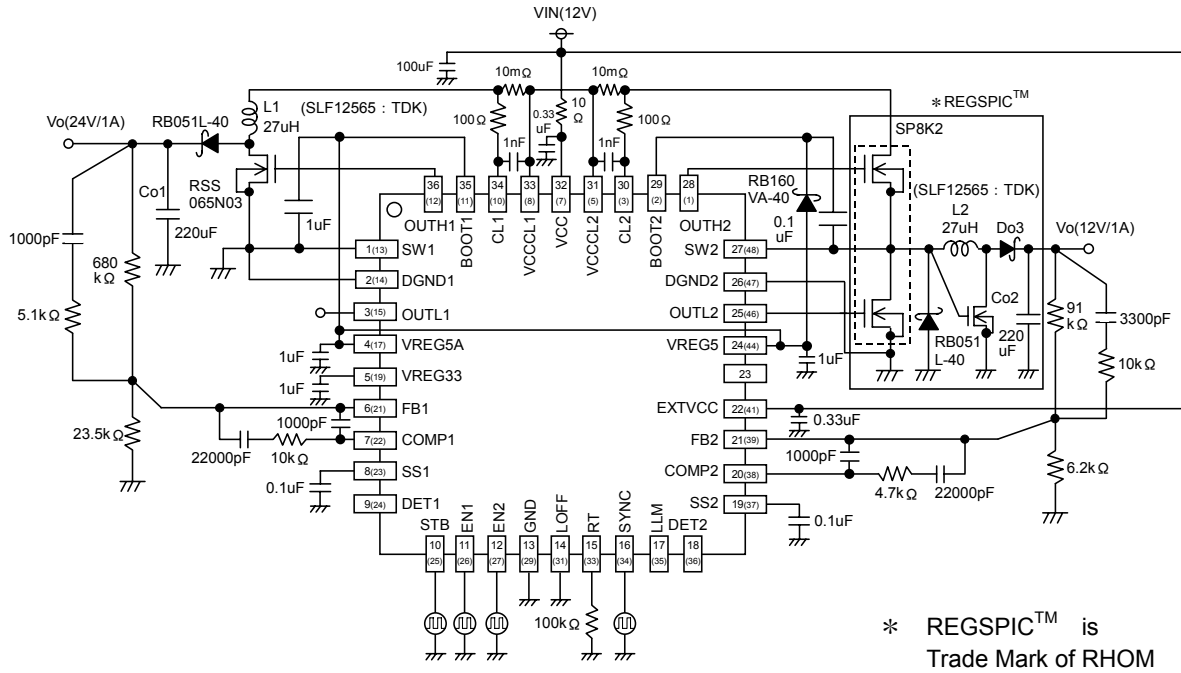

Fig-16C (Step-Down : Low Input Voltage)

There are many factors(The PCB board layout, Output Current, etc.)that can affect the DCDC characteristics. Please verify and confirm using practical applications.

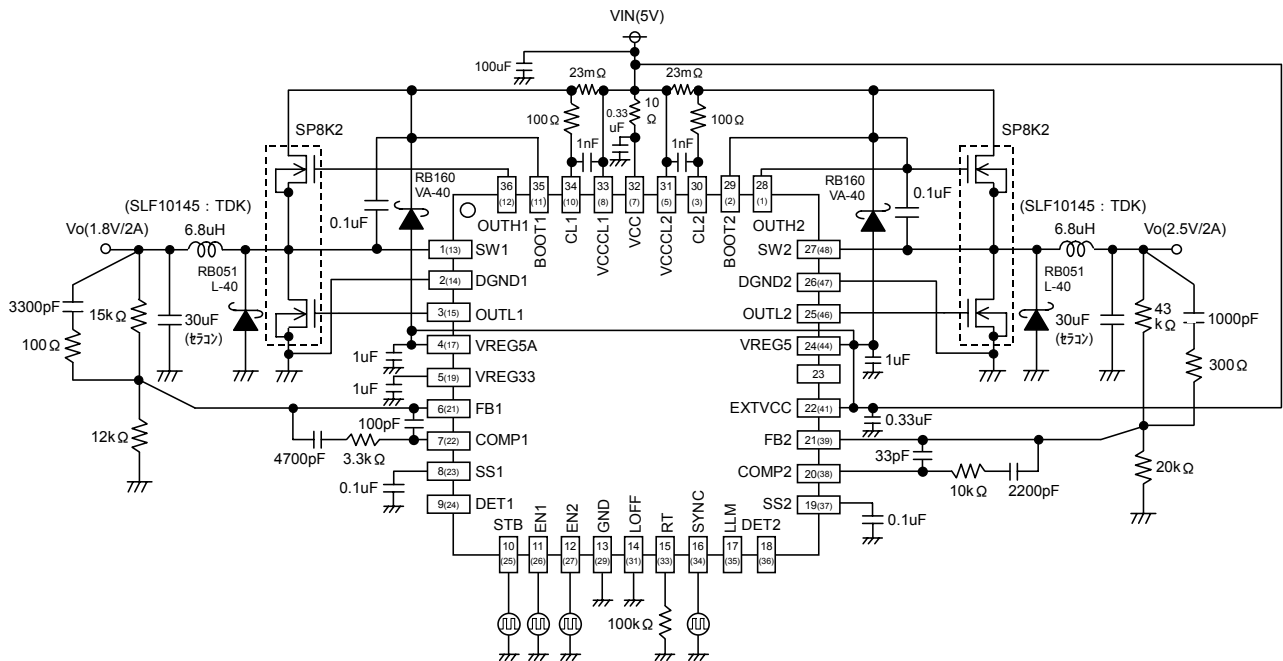

Fig-16D (Step-Up : and Step-Up-Down)

There are many factors(The PCB board layout, Output Current, etc.)that can affect the DCDC characteristics. Please verify and confirm using practical applications.

●Application component selection

(1) Setting the output L value

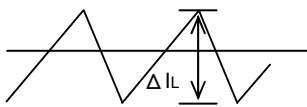

Fig-17

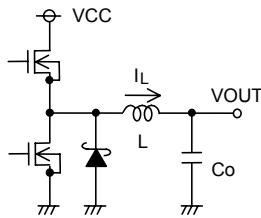

Fig-18

Output ripple current

The coil value significantly influences the output ripple current. Thus, as seen in equation (5), the larger the coil, and the higher the switching frequency, the lower the drop in ripple current.

$$\Delta IL = \frac{(VCC-VOUT) \times VOUT}{L \times VCC \times f} \text{ [A]} \dots (5)$$

The optimal output ripple current setting is 30% of maximum current.

$$\Delta IL = 0.3 \times IOUTmax.[A] \dots (6)$$

$$L = \frac{(VCC-VOUT) \times VOUT}{\Delta IL \times VCC \times f} \text{ [H]} \dots (7)$$

( $\Delta IL$  : output ripple current  $f$  : switching frequency)

※Outputting a current in excess of the coil current rating will cause magnetic saturation of the coil and decrease efficiency.

Please establish sufficient margin to ensure that peak current does not exceed the coil current rating.

※Use low resistance (DCR, ACR) coils to minimize coil loss and increase efficiency.

(2) Setting the output capacitor Co value

Select the output capacitor with the highest value for ripple voltage ( $V_{PP}$ ) tolerance and maximum drop voltage (at rapid load change). The following equation is used to determine the output ripple voltage.

$$\text{Step down } \Delta V_{PP} = \Delta IL \times R_{ESR} + \frac{\Delta IL}{Co} \times \frac{Vo}{Vcc} \times \frac{1}{f} \text{ [V]} \quad \text{Note: } f : \text{ switching frequency}$$

Be sure to keep the output Co setting within the allowable ripple voltage range.

※Please allow sufficient output voltage margin in establishing the capacitor rating. Note that low-ESR capacitors enable lower output ripple voltage.

Also, to meet the requirement for setting the output startup time parameter within the soft start time range, please factor in the conditions described in the capacitance equation (9) for output capacitors, below.

$$Co \leq \frac{TSS \times (Limit - IOUT)}{VOUT} \dots (9) \quad \begin{matrix} Tss : \text{ soft start time} \\ ILimit : \text{ over current detection value (2/16) reference} \end{matrix}$$

Note: less than optimal capacitance values may cause problems at startup.

(3) Input capacitor selection

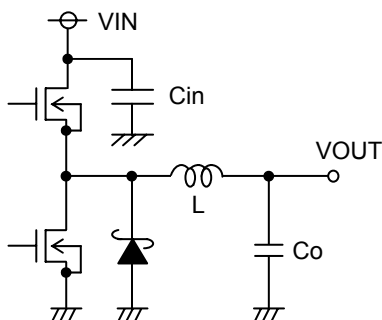

Fig-19

Input capacitor

The input capacitor serves to lower the output impedance of the power source connected to the input pin (VCC). Increased power supply output impedance can cause input voltage (VCC) instability, and may negatively impact oscillation and ripple rejection characteristics. Therefore, be certain to establish an input capacitor in close proximity to the VCC and GND pins. Select a low-ESR capacitor with the required ripple current capacity and the capability to withstand temperature changes without wide tolerance fluctuations. The ripple current IRMSS is determined using equation (10).

$$IRMS = IOUT \times \frac{\sqrt{VOUT (VCC - VOUT)}}{VCC} \text{ [A]} \dots (10)$$

Also, be certain to ascertain the operating temperature, load range and MOSFET conditions for the application in which the capacitor will be used, since capacitor performance is heavily dependent on the application's input power characteristics, substrate wiring and MOSFET gate drain capacity.



(4) Feedback resistor design

Please refer to the following equation in determining the proper feedback resistance. The recommended setting is in a range between 10kΩ and 330kΩ. Resistance less than 10kΩ risks decreased power efficiency, while setting the resistance value higher than 330kΩ will result in an internal error amp input bias current of 0.2uA increasing the offset voltage.

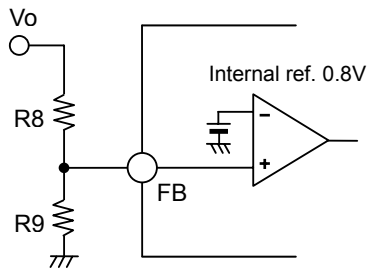

$$V_o = \frac{R8 + R9}{R9} \times 0.8 [V] \dots (11)$$

Fig-20

(5) Setting switching frequency

The triangular wave switching frequency can be set by connecting a resistor to the RT 15(33) pin. The RT sets the frequency by adjusting the charge/discharge current in relation to the internal capacitor. Refer to the figure below in determining proper RT resistance, noting that the recommended resistance setting is between 50kΩ and 130kΩ. Settings outside this range may render the switching function inoperable, and proper operation of the controller overall cannot be guaranteed when unsupported resistance values are used.

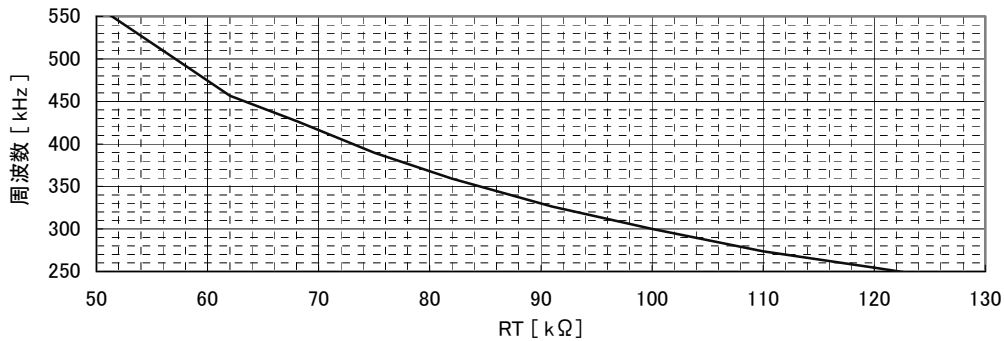
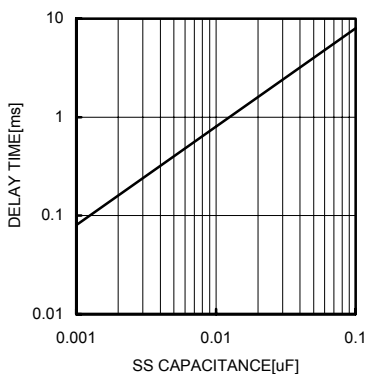

Fig-21 RT vs. switching frequency

(6) Setting the soft start delay

The soft start function is necessary to prevent an inrush of coil current and output voltage overshoot at startup. The figure below shows the relation between soft start delay time and capacitance, which can be calculated using equation (12) at right.



$$TSS = \frac{0.8V(\text{typ.}) \times CSS}{ISS(10\mu A \text{ Typ.})} [\text{sec}] \dots (12)$$

Fig-22 SS capacitance vs. delay time

Recommended capacitance values are between 0.01uF and 0.1uF. Capacitance lower than 0.01uF may generate output overshoots. Please use high accuracy components (such as X5R) when implementing sequential startups involving other power sources. Be sure to test the actual devices and applications to be used, since the soft start time varies, depending on input voltage, output voltage and capacitance, coils and other characteristics.

(7) Setting over current detection values

The current limit value (ILimit) is determined by the resistance of the RCL established between CL and VCCCL.

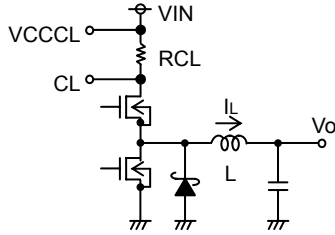

Fig-23

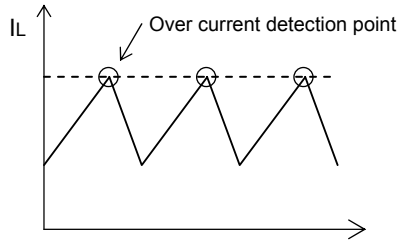

Fig-24

$$I_{Limit} = \frac{90m}{RCL} [A] \dots (13)$$

There are 2 current limit function (ON/OFF control type and OFF latch type) toggled by LOFF pin.

- LOFF=L (0<LOFF<1V): Off Latch Type Current Limit

The output becomes OFF and latched when SS=H and, current limit operation, and the output voltage is less than or equal to 70% of Vo. The OFF latch is deactivated by re-inputting EN signal or VCC control input (switch OFF and ON once more).

- LOFF=H (1<LOFF<VREG5): ON/OFF Control Type Current Limit

When the current goes beyond the threshold value, the current can be limited by reducing the ON Duty Cycle. When the load goes back to the normal operation, the output voltage also becomes back on to the specific level.

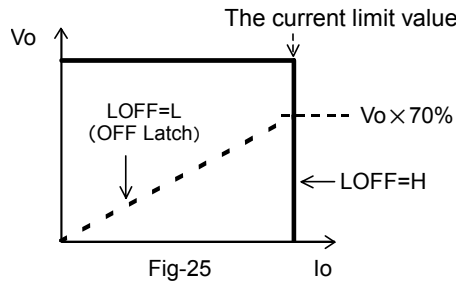

Fig-25

(8) Method for determining phase compensation

Conditions for application stability

Feedback stability conditions are as follows:

- When gain is 1 (0dB) and phase shift is 150° or less (i.e., phase margin is at least 30°):  
a dual-output high-frequency step-down switching regulator is required

Additionally, in DC/DC applications, sampling is based on the switching frequency; therefore, overall GBW may be set at no more than 1/10 the switching frequency. In summary, target characteristics for application stability are:

- Phase shift of 150° or less (i.e., phase margin of 30° or more) with gain of 1 (0dB)
- GBW (i.e., gain 0dB frequency) no more than 1/10 the switching frequency.

Stability conditions mandate a relatively higher switching frequency, in order to limit GBW enough to increase response.

The key to achieving successful stabilization using phase compensation is to cancel the secondary phase margin/delay (-180°) generated by LC resonance, by employing a dual phase lead. In short, adding two phase leads stabilizes the application.

GBW (the frequency at gain 1) is determined by the phase compensation capacitor connected to the error amp. Thus, a larger capacitor will serve to lower GBW if desired.

- ① General use integrator (low-pass filter)    ② Integrator open loop characteristics

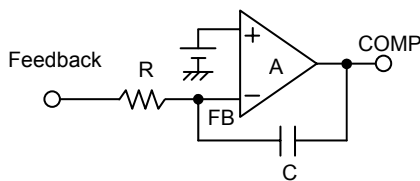

Fig-26

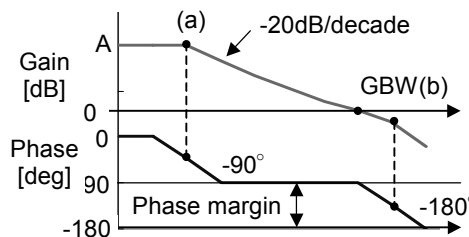

Fig-27

$$\text{point (a) } f_a = \frac{1}{2\pi R C A} \quad 1.25[\text{Hz}]$$

$$\text{point (b) } f_a = \text{GBW} \frac{1}{2\pi R C} \quad [\text{Hz}]$$

The error amp is provided with phase compensation similar to that depicted in figures ① and ② above and thus serves as the system's low-pass filter.

In DC/DC converter applications, R is established parallel to the feedback resistance.

When electrolytic or other high-ESR output capacitors are used:

Phase compensation is relatively simple for applications employing high-ESR output capacitors (on the order of several  $\Omega$ ). In DC/DC converter applications, where LC resonance circuits are always incorporated, the phase margin at these locations is  $-180^\circ$ . However, wherever ESR is present, a  $90^\circ$  phase lead is generated, limiting the net phase margin to  $-90^\circ$  in the presence of ESR. Since the desired phase margin is in a range less than  $150^\circ$ , this is a highly advantageous approach in terms of the phase margin. However, it also has the drawback of increasing output voltage ripple components.

③ LC resonance circuit

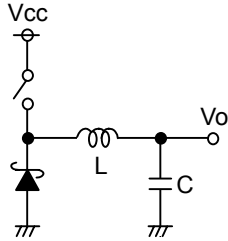

Fig-28

$$f_r = \frac{1}{2\pi\sqrt{LC}} \text{ [Hz]}$$

Resonance point phase margin  $-180^\circ$

④ ESR connected

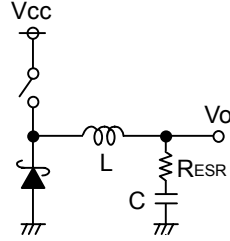

Fig-29

$$f_r = \frac{\text{resonance point1}}{2\pi\sqrt{LC}} \text{ [Hz] : Resonance Point}$$

$$f_{ESR} = \frac{1}{2\pi R_{ESR}C} \text{ [Hz] : Zero}$$

$-90^\circ$  : Pole

Since ESR changes the phase characteristics, only one phase lead need be provided for high-ESR applications. Please choose one of the following methods to add the phase lead.

⑤ Add C to feedback resistor

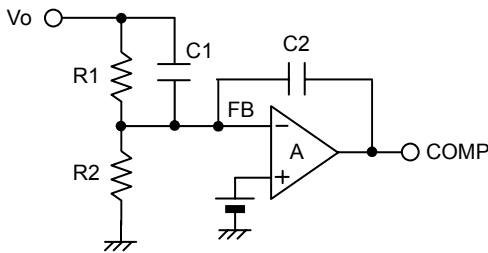

Fig-30

$$\text{Phase lead } f_z = \frac{1}{2\pi C_1 R_1} \text{ [Hz]}$$

⑥ Add R3 to aggregator

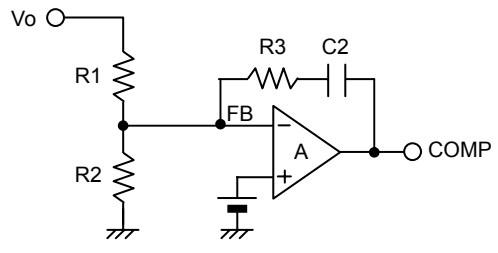

Fig-31

$$\text{Phase lead } f_z = \frac{1}{2\pi C_2 R_3} \text{ [Hz]}$$

Set the phase lead frequency close to the LC resonance frequency in order to cancel the LC resonance.

When using ceramic, OS-CON, or other low-ESR capacitors for the output capacitor:

Where low-ESR (on the order of tens of  $m\Omega$ ) output capacitors are employed, a two phase-lead insertion scheme is required, but this is different from the approach described in figure ③~⑥, since in this case the LC resonance gives rise to a  $180^\circ$  phase margin/delay. Here, a phase compensation method such as that shown in figure ⑦ below can be implemented.

⑦ Phase compensation provided by secondary (dual) phase lead

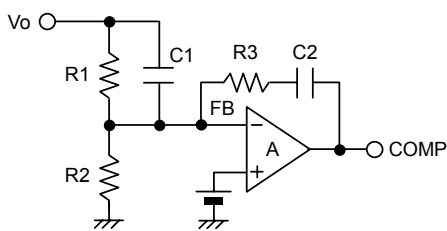

Fig-32

$$\text{Phase lead } f_{z1} = \frac{1}{2\pi R_1 C_1} \text{ [Hz]}$$

$$\text{Phase lead } f_{z2} = \frac{1}{2\pi R_3 C_2} \text{ [Hz]}$$

$$\text{LC resonance frequency } f_r = \frac{1}{2\pi\sqrt{LC}} \text{ [Hz]}$$

Once the phase-lead frequency is determined, it should be set close to the LC resonance frequency.

This technique simplifies the phase topology of the DCDC Converter. Therefore, it might need a certain amount of trial-and-error process. There are many factors(The PCB board layout, Output Current, etc.)that can affect the DCDC characteristics. Please verify and confirm using practical applications.

(9) MOSFET selection

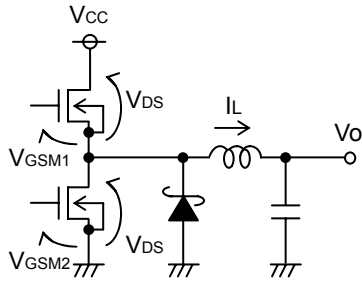

Fig-33

FET uses Nch MOS

- $V_{DS} > V_{CC}$
- $V_{GSM1} > \text{BOOT-SW interval voltage}$
- $V_{GSM2} > V_{REG5}$
- Allowable current  $>$  voltage current + ripple current
- ※ Should be at least the over current protection value
- ※ Select a low ON-resistance MOSFET for highest efficiency

(10) Schottky barrier diode selection

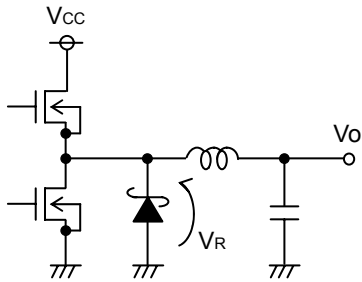

Fig-34

- Reverse voltage  $V_R > V_{CC}$
- Allowable current  $>$  voltage current + ripple current
- ※ Should be at least the over current protection value
- ※ Select a low forward voltage, fast recovery diode for highest efficiency
- The shoot-through may happen when the input parasitic capacitance of FET is extremely big or the Duty ratio is less than or equal to 10%. Less than or equal to 1000pF input parasitic capacitance is recommended. Please confirm operation on the actual application since this character is affected by PCB layout and components.

(11) Sequence function

● Circuit diagram

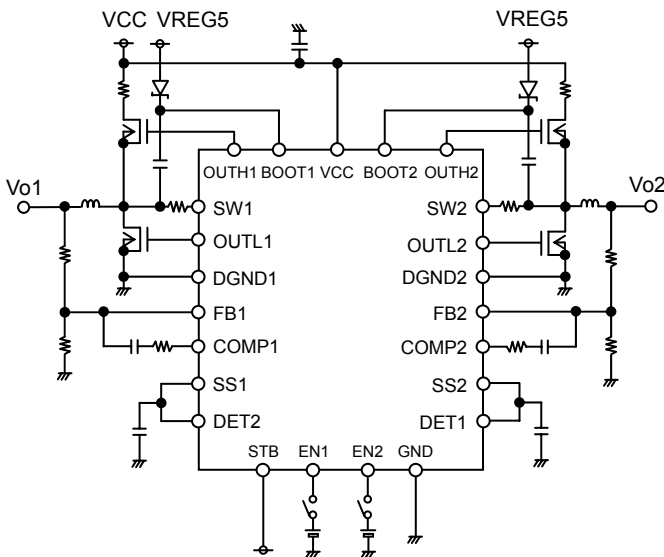

Fig-35

● Timing chart

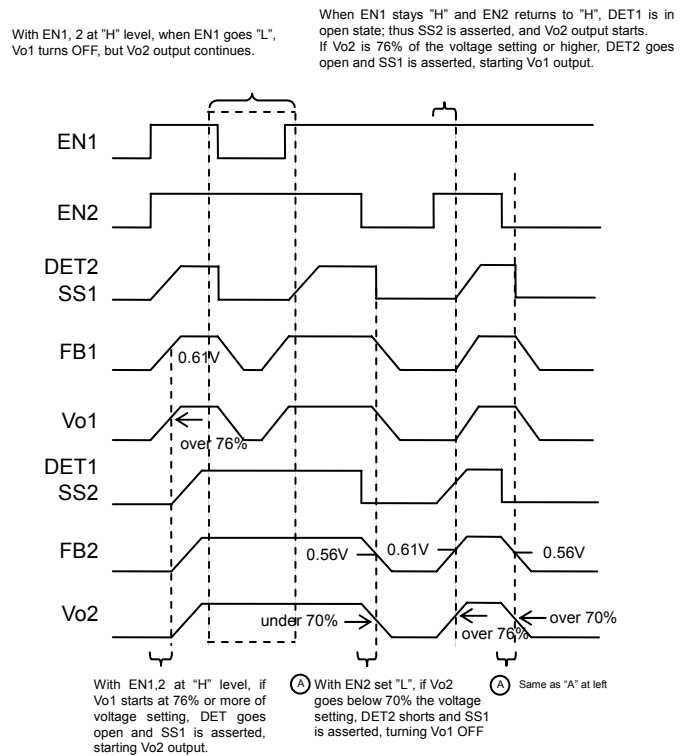
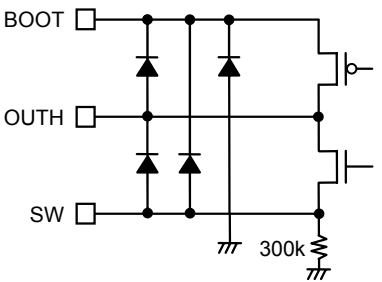
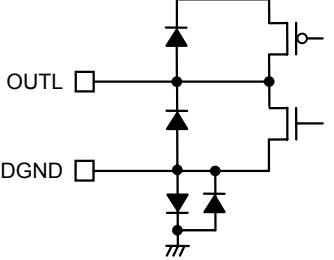
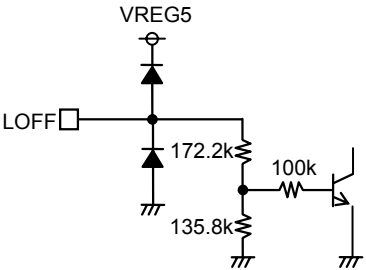
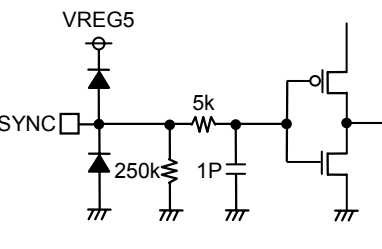
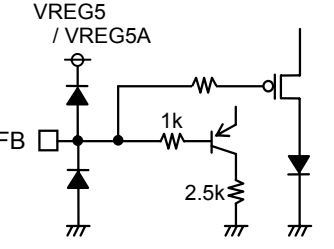
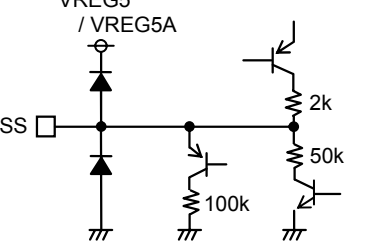
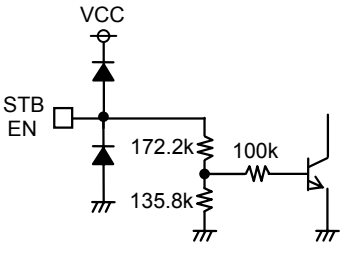
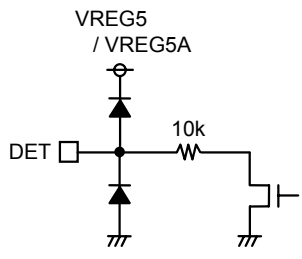
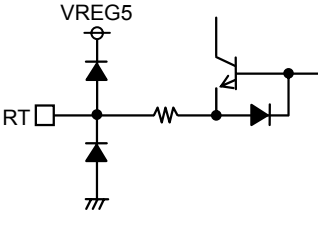
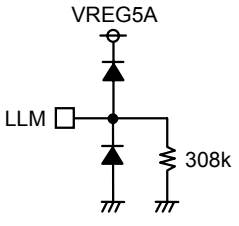
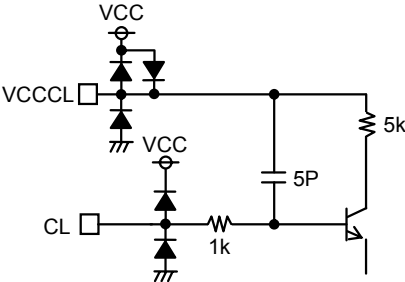
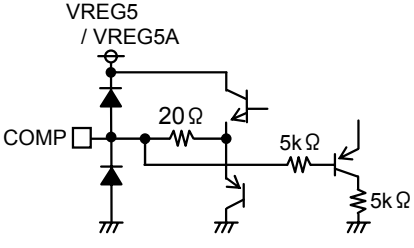
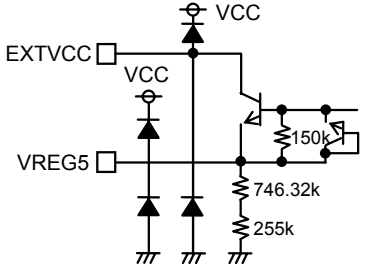
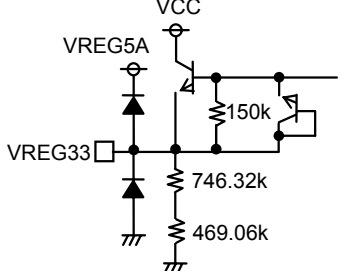
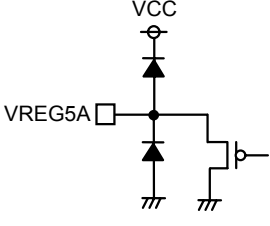

Fig-36

● Input/Output equivalent circuits (Items in parentheses apply to VQFP48C)

<p>1(13), 27(48)PIN (SW1, SW2) 29(2), 35(11)PIN (BOOT2, BOOT1) 28(1), 36(15)PIN (OUTH1, OUTH2)</p>	<p>2(14), 26(47)PIN (DGND1, DGND2) 3(15), 25(46)PIN (OUTL1, OUTL2) 24(44) VREG5 / 4(17)VREG5A</p>	<p>14(31)PIN (LOFF)</p>
		
<p>16(34)PIN (SYNC)</p>	<p>6(21), 21(39)PIN (FB1, FB2)</p>	<p>8(23), 19(37)PIN (SS1, SS2)</p>
		
<p>10(25), 11(26), 12(27)PIN (STB, EN1, EN2)</p>	<p>9(24), 18(36)PIN (DET1, DET2)</p>	<p>15(33)PIN (RT)</p>
		
<p>17(35)PIN (LLM)</p>	<p>30(3), 34(10)PIN (CL2, CL1) 31(5), 33(8)PIN (VCCCL2, VCCCL1)</p>	<p>7(22), 20(38)PIN (COMP1, COMP2)</p>
		
<p>22(41)PIN (EXTV, CC) 24(44)PIN (VREG5)</p>	<p>5(19)PIN (VREG33)</p>	<p>4(17)DIN (VREG5A)</p>
		

● Operation notes

1) Absolute maximum ratings

Exceeding the absolute maximum ratings for supply voltage, operating temperature or other parameters can damage or destroy the IC. When this occurs, it is impossible to identify the source of the damage as a short circuit, open circuit, etc. Therefore, if any special mode is being considered with values expected to exceed absolute maximum ratings, consider taking physical safety measures to protect the circuits, such as adding fuses.

2) GND electric potential

Keep the GND terminal potential at the lowest (minimum) potential under any operating condition.

3) Thermal design

Be sure that the thermal design allows sufficient margin for power dissipation (Pd) under actual operating conditions.

4) Inter-pin shorts and mounting errors

Use caution when positioning the IC for mounting on printed surface boards. Connection errors may result in damage or destruction of the IC. The IC can also be damaged when foreign substances short output pins together, or cause shorts between the power supply and GND.

5) Operation in strong electromagnetic fields

Use caution when operating in the presence of strong electromagnetic fields, as this may cause the IC to malfunction.

6) Testing on application boards

Connecting a capacitor to a low impedance pin for testing on an application board may subject the IC to stress. Be sure to discharge the capacitors after every test process or step. Always turn the IC power supply off before connecting it to or removing it from any of the apparatus used during the testing process. In addition, ground the IC during all steps in the assembly process, and take similar antistatic precautions when transporting or storing the IC.

7) The output FET

The shoot-through may happen when the input parasitic capacitance of FET is extremely big or the Duty ratio is less than or equal to 10%. Less than or equal to 1000pF input parasitic capacitance is recommended. Please confirm operation on the actual application since this character is affected by PCB layout and components.

8) This monolithic IC contains P+ isolation and P substrate layers between adjacent elements in order to keep them isolated.

P-N junctions are formed at the intersection of these P layers with the N layers of other elements, creating a parasitic diode or transistor. Relations between each potential may form as shown in the example below, where a resistor and transistor are connected to a pin:

- With the resistor, when  $GND > Pin A$ , and with the transistor (NPN), when  $GND > Pin B$ :  
The P-N junction operates as a parasitic diode
- With the transistor (NPN), when  $GND > Pin B$ :  
The P-N junction operates as a parasitic transistor by interacting with the N layers of elements in proximity to the parasitic diode described above.

Parasitic diodes inevitably occur in the structure of the IC. Their operation can result in mutual interference between circuits, and can cause malfunctions, and, in turn, physical damage or destruction. Therefore, do not employ any of the methods under which parasitic diodes can operate, such as applying a voltage to an input pin lower than the (P substrate) GND.

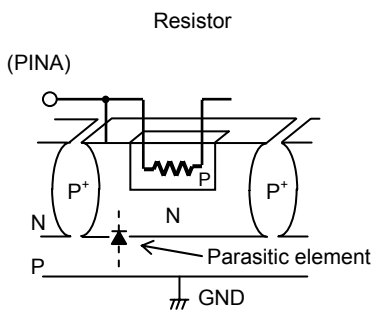

Fig-37

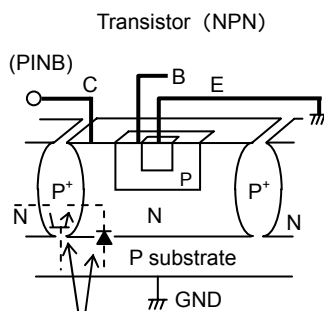

Fig-38

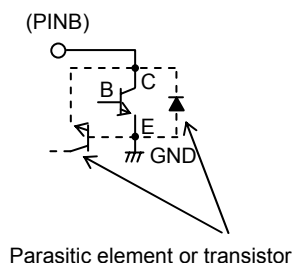

Fig-39

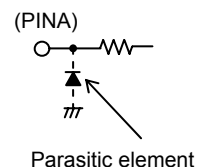
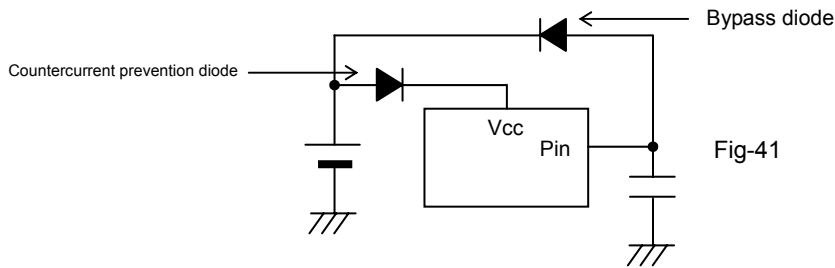

Fig-40

9) GND wiring pattern

When both a small-signal GND and high current GND are present, single-point grounding (at the set standard point) is recommended, in order to separate the small-signal and high current patterns, and to be sure voltage changes stemming from the wiring resistance and high current do not cause any voltage change in the small-signal GND. In the same way, care must be taken to avoid wiring pattern fluctuations in any connected external component GND.

10) In some application and process testing, Vcc and pin potential may be reversed, possibly causing internal circuit or element damage. For example, when the external capacitor is charged, the electric charge can cause a Vcc short circuit to the GND. In order to avoid these problems, limiting output pin capacitance to 100 μF or less and inserting a Vcc series countercurrent prevention diode or bypass diode between the various pins and the Vcc is recommended.



11) Thermal shutdown (TSD)

This IC is provided with a built-in thermal shutdown (TSD) circuit, which is designed to prevent thermal damage to or destruction of the IC. Normal operation should be within the power dissipation parameter, but if the IC should run beyond allowable Pd for a continued period, junction temperature (Tj) will rise, thus activating the TSD circuit, and turning all output pins OFF. When Tj again falls below the TSD threshold, circuits are automatically restored to normal operation. Note that the TSD circuit is only asserted beyond the absolute maximum rating. Therefore, under no circumstances should the TSD be used in set design or for any purpose other than protecting the IC against overheating

12) The SW pin

When the SW pin is connected in an application, its coil counter-electromotive force may give rise to a single electric potential. When setting up the application, make sure that the SW pin never exceeds the absolute maximum value. Connecting a resistor of several Ω will reduce the electric potential. (See Fig. 43)

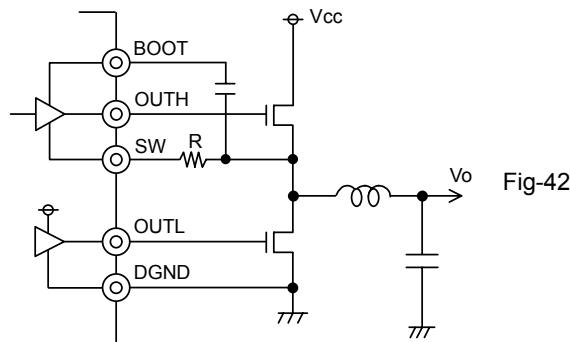

13) Dropout operation

When input voltage falls below approximately output voltage / 0.9 (varying depending on operating frequency) the ON interval on the OUTL side MOS is lost, making boost applications and wrap operation impossible. If a small differential between input and output voltage is envisioned for a prospective application, connect the load such that the SW voltage drops to the GND level. Managing this load requires discharging the SW line capacitance (SW pin capacitance: approx. 500pF; OUTL side MOS D-S capacitance; Schottky capacitance). Supported loads can be calculated using the equation below.

$$I_{LOAD} = \frac{\text{Output voltage} \times \text{SW line capacitance}}{25n}$$

Note that SW line capacitance is lower with smaller loads, and more stable operation is attained when low voltage bias circuits are configured as in the example below (Fig. 44). However, the degree to which line capacitance is reduced or operational stability is attained will vary depending on the board layout and components. Therefore, be certain to confirm the effectiveness of these design factors in actual operation before entering mass production.

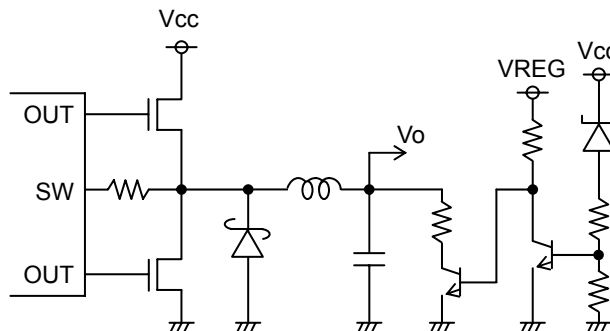
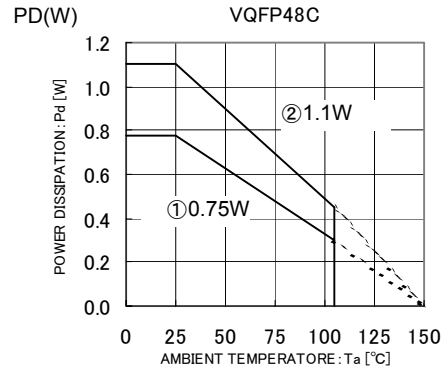
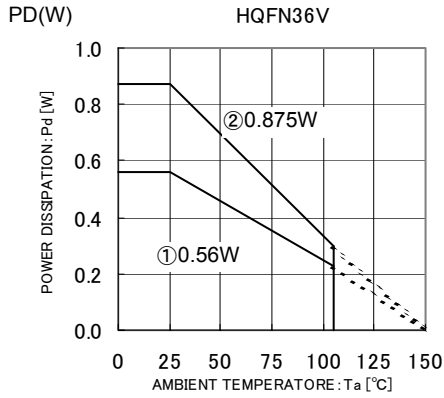

Fig-43

● Power dissipation vs. temperature characteristics



① : Stand-alone IC  
 ② : Mounted on Rohm standard board  
 (70mm x 70mm x 1.6mm glass-epoxy board )

① : Stand-alone IC  
 ② : Mounted on Rohm standard board  
 (70mm x 70mm x 1.6mm glass-epoxy board)

● Part order number

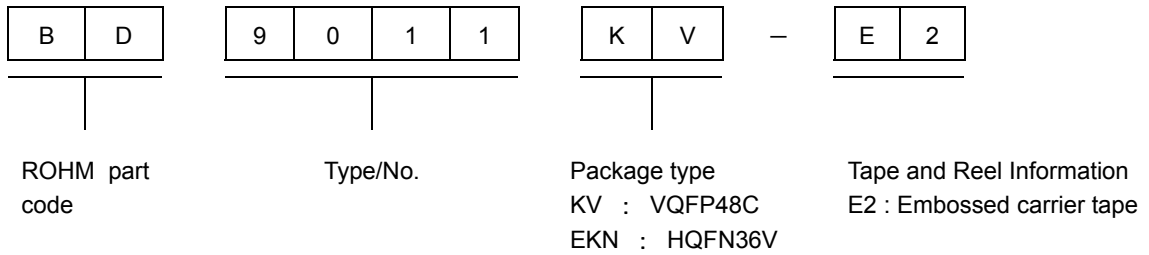

**HQFN36V**

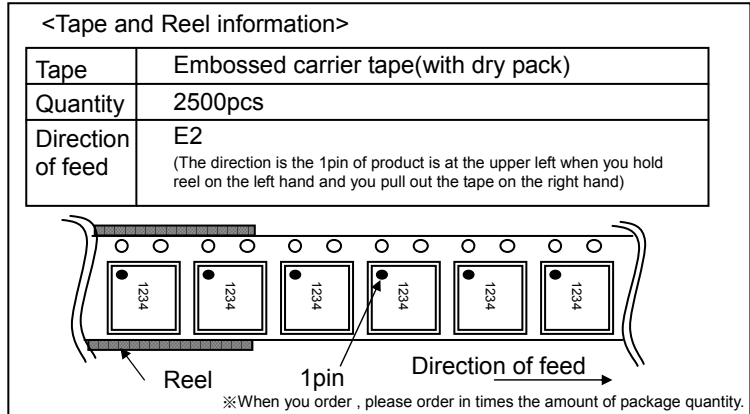
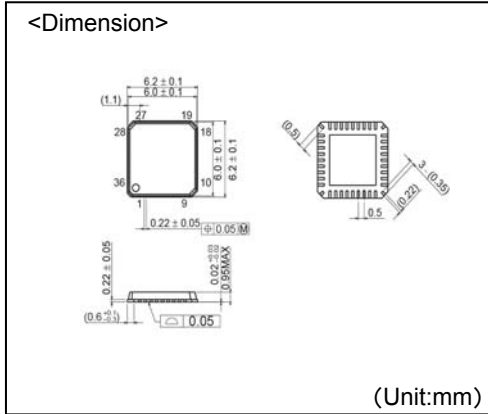

**VQFP48C**

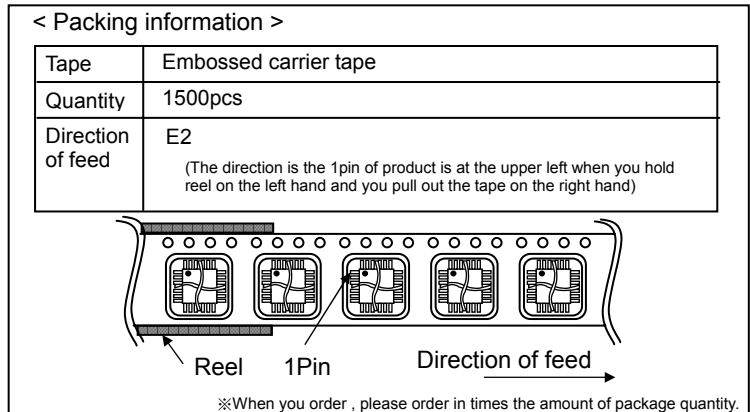
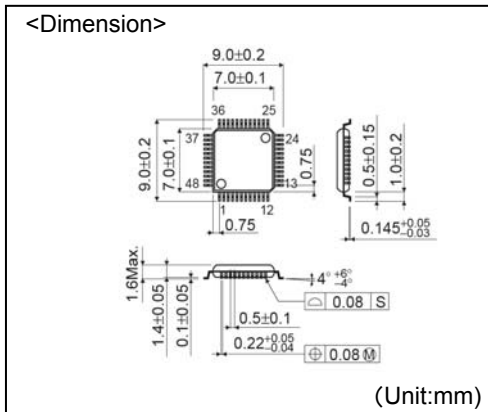



■BD9775FV (1channel synchronous rectification configuration)

●Description

BD9775FV is Switching Controller with synchronous rectification(BD9775FV is 1channel synchronous rectification) and wide input range. It can contribute to ecological design(lower power consumption) for most of electronic equipments.

●Features (BD9775FV)

- 1) 2channel Step-Down DC/DC FET driver
- 2) Synchronous rectification for channel 2
- 3) Able to synchronize to an external clock signal
- 4) Over Current Protection (OCP) by monitoring VDS of P channel FET
- 5) Short Circuit Protection (SCP) by delay time and latch method
- 6) Under Voltage Lock Out (UVLO)
- 7) Thermal Shut Down (TSD)
- 8) Package : SSOP-B28

●Applications (BD9775FV)

Car navigation system, Car Audio, Display, Flat TV

●Absolute maximum ratings (Ta=25°C)(BD9775FV)

Parameter	Symbol	Limits	Units
Supply Voltage (VCC to GND)	Vcc	36	V
VREF to GND Voltage	Vref	7	V
VREGA to GND Voltage	Vrega	7	V
VREGB to VCC Voltage	Vregb	7	V
OUT1, OUT2H to VCC Voltage	Vouth	7	V
OUT2L to GND Voltage	Voutl	7	V
Power Dissipation	Pd	640(*1)	mW
Operating Temperature Range	Topr	-40 to +85	°C
Storage Temperature Range	Tstg	-55 to +125	°C
Junction Temperature	Tjmax	+125	°C

(\*1) Without heat sink, reduce to 6.4mW when Ta=25°C or above

Pd is 850mW mounted on 70x70x1.6mm, and reduce to 8.5mW/°C above 25°C.

● Recommended operating conditions (Ta=-25 to +75°C) (BD9775FV)

Parameter	Symbol	Limits			Units
		MIN	TYP	MAX	
Supply Voltage	VCC	6.0	-	30.0	V
Oscillating Frequency	f <sub>osc</sub>	30	100	300	KHz
Timing Resistance	RT	10	27	56	KΩ
Timing Capacitance	CT	100	470	4700	pF

● Electrical characteristics (Ta=25°C, VCC=13.2V, fosc=100kHz, CTL1=3V, CTL2=3V) (BD9775FV)

Parameter	Symbol	Limits			Unit	Condition
		Min.	Typ.	Max.		
<b>【Whole Device】</b>						
Stand-by Current	I <sub>ccst</sub>	—	—	5	μA	CTL1,CTL2=0V
Circuit Current	I <sub>cc</sub>	2.5	4.2	7	mA	FB1,FB2=0V
<b>【Reference Voltage】</b>						
VREF Output Voltage	V <sub>ref</sub>	2.97	3.00	3.03	V	I <sub>o</sub> =-1mA
Line Regulation	DV <sub>li</sub>	—	—	10	mV	V <sub>cc</sub> =7 to 18V,I <sub>o</sub> =-1mA
Load Regulation	DV <sub>lo</sub>	—	—	10	mV	I <sub>o</sub> =-0.1mA to -2mA
Short Output Current	I <sub>os</sub>	-60	-22	-5	mA	
<b>【Internal Voltage Regulator】</b>						
VREGA Output Voltage	V <sub>rega</sub>	4.5	5.0	5.5	V	Switching with C <sub>OUT</sub> =5000pF
VREGB Output Voltage	V <sub>regb</sub>	V <sub>CC</sub> -5.5	V <sub>CC</sub> -5.0	V <sub>CC</sub> -4.5	V	Switching with C <sub>OUT</sub> =5000pF
VREGB Dropout Voltage	V <sub>dregb</sub>	—	1.8	2.2	V	VREGB to GND Voltage
<b>【Oscillator】</b>						
Oscillating Frequency	f <sub>osc</sub>	90	100	110	kHz	RT=27kΩ,CT=470pF
Frequency Tolerance	Df <sub>osc</sub>	—	—	2	%	V <sub>cc</sub> =7 to 18V
<b>【Synchronized Frequency】</b>						
Synchronized Frequency	f <sub>osc2</sub>	—	120	—	kHz	FIN=120kHz
FIN Threshold Voltage	V <sub>thfin</sub>	1.2	1.4	1.6	V	
FIN Input Current	I <sub>FIN</sub>	-1	—	1	μA	V <sub>FIN</sub> =1.4V
<b>【Error Amplifier】</b>						
Threshold Voltage	V <sub>thea</sub>	0.98	1.00	1.02	V	
INV Input Bias Current	I <sub>bias</sub>	-1	—	1	μA	
Voltage Gain	A <sub>v</sub>	—	70	—	dB	DC
Band Width	B <sub>w</sub>	—	2.0	—	MHz	A <sub>v</sub> =0dB
Maximum Output Voltage	V <sub>fbh</sub>	2.2	2.4	2.6	V	INV=0.5V
Minimum Output Voltage	V <sub>fbL</sub>	—	—	0.1	V	INV=1.5V
Output Sink Current	I <sub>sink</sub>	0.5	2	5.2	mA	FB1,2 Terminal
Output Source Current	I <sub>source1</sub>	-170	-110	-70	μA	FB1 Terminal
	I <sub>source2</sub>	-200	-130	-85	μA	FB2 Terminal

Parameter	Symbol	Limits			Unit	Condition
		Min.	Typ.	Max.		
<b>【PWM Comparator】</b>						
Threshold Voltage at 0%	Vth0	0.88	0.98	1.08	V	FB Voltage
Threshold Voltage at 100%	Vth100	1.88	1.98	2.08	V	FB Voltage
DTC Input Bias Current	ldtc	-1	—	1	$\mu$ A	
<b>【FET Driver】</b>						
Sink Current	Isink	20	36	58	mA	VDS=0.4V
Source Current	Isource	-510	-320	-180	mA	VDS=0.4V
ON Resistance	RonN	7.0	11.0	17.8	$\Omega$	OUT1,2H,2L : L
	RonP	0.7	1.4	2.2	$\Omega$	OUT1,2H,2L : H
Rise Time	Tr	—	20	—	nsec	Switching with COU=5000pF
Fall Time	Tf	—	100	—	nsec	Switching with COU=5000pF
Driver's Duty Cycle of Synchronous Rectification	$\Delta$ Duty	42	45	48	%	RSYNC=30K $\Omega$ , 50% of main driver's duty cycle
SYNC Terminal Voltage	Vsync	1.45	1.55	1.65	V	Rsync=30K $\Omega$ ,FB=1.5V
<b>【Over Current Protection (OCP)】</b>						
VS Threshold Voltage	Vths	VCC-0.24	VCC-0.21	VCC-0.18	V	RCL=21k $\Omega$ , the output tern off after detected 8 cycle
VS Input Current	IVSH	-1	—	1	$\mu$ A	VS1,VS2=PBU
	IVSL	-1	—	1	$\mu$ A	VS1,VS2=0V
CL Input Current	Icl	9	10	11	$\mu$ A	
<b>【Stand-by】</b>						
Threshold Voltage	Vctl	1.0	1.5	2.0	V	
CL Input Current	Ictl	6	15	30	$\mu$ A	CTL1,CTL2=3V
<b>【Short Circuit Protection (SCP)】</b>						
Timer Start Voltage	Vtime	0.6	0.7	0.8	V	INV Voltage
Threshold Voltage	Vthscp	1.92	2.00	2.08	V	SCP Voltage
Stand-by Voltage	Vstscp	—	10	100	mV	SCP Voltage
Source current	Isoscp	-4.0	-2.5	-1.5	$\mu$ A	SCP=1.0V
<b>【Under Voltage Lock Out (UVLO)】</b>						
Threshold Voltage	Vuvlo	5.6	5.7	5.8	V	Vcc sweep down
Hysteresis Voltage Range	DVuvlo	0.05	0.1	0.15	V	

● Pin Description

(BD9775FV)

1	FB1	VS1	28
2	INV1	CL1	27
3	RT	PVCC1	26
4	CT	OUT1	25
5	Fin	VREGB	24
6	GND	OUT2H	23
7	VREF	PVCC2	22
8	DTC1	CL2	21
9	DTC2	VS2	20
10	INV2	SCP	19
11	FB2	VREGA	18
12	CTL1	OUT2L	17
13	CTL2	PGND	16
14	VCC	SYNC	15

● PinNo/PinName (BD9775FV)

Pin No.	Pin Name	Description
1	FB1	Error amplifier output pin (Channel 1)
2	INV1	Error amplifier negative input pin (Channel 1)
3	RT	Oscillator frequency adjustment pin connected resistor
4	CT	Oscillator frequency adjustment pin connected capacitor
5	FIN	Oscillator synchronization pulse signal input pin
6	GND	Low-noise ground
7	VREF	Reference voltage output pin
8	DTC1	Maximum duty and soft start adjustment pin (Channel 1)
9	DTC2	Maximum duty and soft start adjustment pin (Channel 2)
10	INV2	Error amplifier negative input pin (Channel 2)
11	FB2	Error amplifier output pin (Channel 2)
12	CTL1	Enable/stand-by control input (Channel 1)
13	CTL2	Enable/stand-by control input (Channel 2)
14	VCC	Main power supply pin
15	SYNC	Synchronous rectification timing adjustable pin
16	PGND	Power ground (connected low-side gate driver and digital ground)
17	OUT2L	Low-side ( synchronous rectifier ) gate driver output pin (Channel 2)
18	VREGA	Connected capacitor for internal regulator
19	SCP	Delay time of short circuit protection adjustment pin connected capacitor
20	VS2	Over current detection voltage monitor pin (connected FET drain, Channel 2)
21	CL2	Over current detection voltage adjustment pin connected capacitor and resistor (Channel 2)
22	PVCC2	High-side gate driver power supply input (Channel 2)
23	OUT2H	High-side gate driver output pin (Channel 2)
24	VREGB	Connected capacitor for internal regulator
25	OUT1	High-side gate driver output pin (Channel 1)
26	PVCC1	High-side gate driver power supply input (Channel 1)
27	CL1	Over current detection voltage adjustment pin connected capacitor and resistor (Channel 1)
28	VS1	Over current detection voltage monitor pin (connected FET drain, Channel 1)

● Block Diagram (BD9775FV)

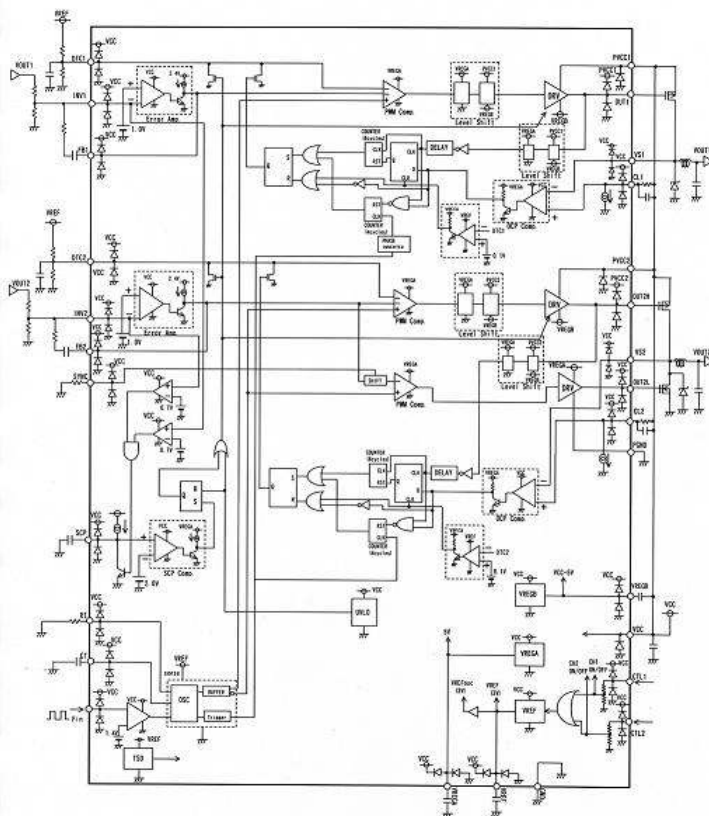

● FUNCTION EXPLANATION (BD9775FV)

1. DC/DC Converter

• Reference Voltage

Stable voltage of compensated temperature, is generated from the power supply voltage (VCC). The reference voltage is 3.0V, the accuracy is  $\pm 1\%$ . Place a capacitor with low ESR (several decades  $m\Omega$ ) between VREF and GND.

• Internal Regulator A (VREGA)

5V is generated the power supply voltage. The voltage is for the driver of the synchronous rectification's MOSFET. Place a capacitor with low ESR (several decades  $m\Omega$ ) between VREGA and PGND.

- Internal regulator B (VREGB)  
(VCC-5V) is generated from the power supply voltage. The voltage is for the driver of the main MOSFET switch. Place a capacitor with low ESR (several decades  $m\Omega$ ) between VREGB and PVCC.
- Oscillator  
Placing a resistor and a capacitor to RT and CT, respectively, generates two triangle waves for both channels, and each wave is opposite phase. The waves are input to the PWM comparators for CH1 and CH2. Also, the oscillating frequency can be slightly adjusted (less than 20%) by putting external clock pulse into Fin pin, which is higher frequency than the fixed one.
- Error Amplifier  
It amplifies the difference, between the establish output voltage and the actual output one detected at INV. And amplified voltage comes out from FB. The comparing voltage is 1.0V and the accuracy is  $\pm 2\%$ . The phase can be compensated externally by placing a resistor and a capacitor between INV and FB.
- PWM Comparator  
It converts the output voltage from error amplifier into PWM waveform, then output to MOSFET driver.
- MOSFET Driver  
The main drivers (OUT1, OUT2H) are for P-channel MOSFETs, and the driver (OUT2L) for synchronous rectification is for N-channel MOSFET. The values of output voltage are clamp to VREGB, VREGA, respectively. All drivers' output configurations are push-pull type. In addition, the output current capability is 36mA for the sink current and 320mA ( $V_{ds}=0.4V$ ) for the source current.

## 2.Channel Control

Each output can be individually turned on or off with CTL1 and CTL2. When the CTL is "H" (more than 1.5V), it becomes turned on.

## 3.Protection

- Over Current Protection (OCP)  
When detected over current (detecting drop voltage of the main MOSFET's ON resistance), the MOSFET switch becomes turned off, and the energy on DTC pin is discharged. After discharged, the output restarts automatically. The level of the OCP detection threshold can be set by the resistance, which is connected between VCC and CL.
- Short Circuit Protection (SCP)  
When either output goes down and the voltage on INV pin gets lower than 0.7V, a capacitor placed on SCP is started to charge.  
When the SCP pin becomes more than 2.0V, the main MOSFET switches of both outputs are turned off; then, the outputs are latched. While they are latched, the IC can be reset by restarting VCC or CTL, or discharging SCP.
- Under Voltage Lock Out (UVLO)  
Due to avoiding malfunctions when the IC is started up or the power supply voltage is rapidly disconnected, the main MOSFET switches become off and DTC is discharged when the supply voltage is less than 5.7V. Also, when the output is latched because of SCP function, the latch becomes reset. Due to preventing malfunctions in the case the power supply voltage fluctuate at near UVLO threshold, there is 0.1V hysteresis between the detection and reset voltage of UVLO threshold.
- Thermal Shut Down (TSD)  
Due to preventing breakdown of the IC by heating up, the main MOSFET switches become off and DTC pin is discharged by detecting over temperature of the chip. Due to preventing malfunctions in the case temperature fluctuate at near TSD threshold, there is hysteresis between TSD on and off.

●SETTING UP INFORMATION (BD9775FV)

1) Simultaneously OFF Duty of MOSFETs for Synchronous Rectification

The simultaneously OFF duty of both main MOSFET switch and synchronous rectification MOSFET is determined by resistance (Rsync) between SYNC and GND. See Fig. 4.

In Synchronous Rectification, insert RFB2-GND (RFB2-GND ≒ 3 × Rsync) between FB2 and GND, because it is possible to reduce overshoot (see fig.2). RFB2-GND decide following formula.

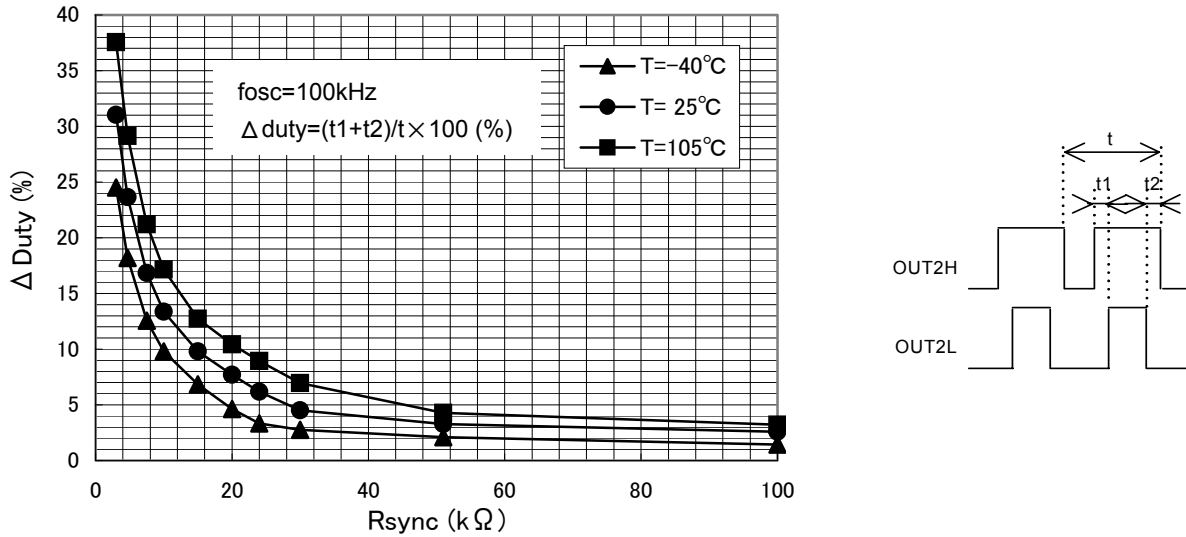

Fig.2

• Resistance at FB2-GND setup condition

$$\frac{\text{Threshold Voltage at 100\%}}{V_{sync}} - \text{Output Source Current at FB2} < R_{FB2-GND} < 3 \times R_{sync}(\text{MIN})$$

$$\frac{2.08}{3 \times R_{sync}(\text{MAX})} < R_{FB2-GND} < 3 \times R_{sync}(\text{MIN})$$

$$\frac{0.4908}{R_{sync}(\text{MAX})} + 80.7 \times 10^{-6} < R_{FB2-GND} < 3 \times R_{sync}(\text{MIN})$$

※Rsync(MAX)···MAX dispersion range at Rsync      Rsync(MIN)···MIN dispersion range at Rsync

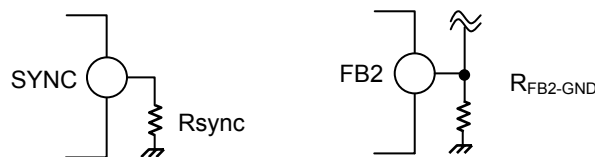

Short SYNC to VREF if the synchronous rectification function is not needed.

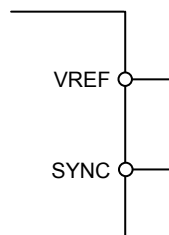

Without Synchronous Rectification (Don't insert RFB2-GND)

2) Oscillator Synchronization by External Pulse Signal

At the operation the oscillator is externally synchronized, input the synchronization signal into Fin in addition to connect a resistor and a capacitor at RT and CT, respectively.

Input the external clock pulse on Fin, which is higher frequency than the fixed one. However, the frequency variation should be less than 20%.

Also, the duty cycle of the pulse should be set from 10% to 90%.

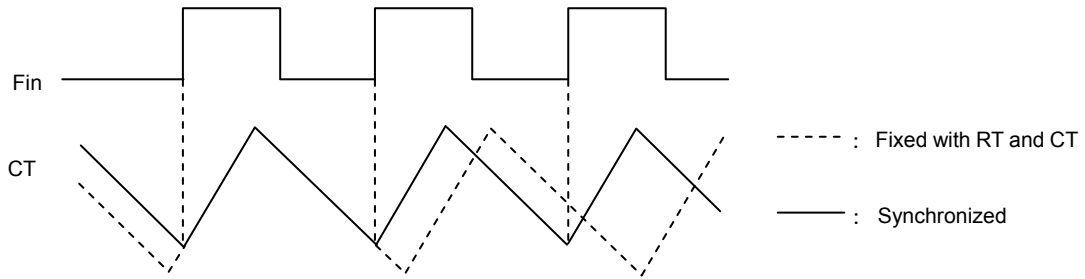

CT Waveform during Synchronized with External Pulse

Short Fin to GND if the function of external synchronization is not needed.

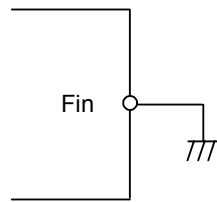

Without Synchronization Signal

3) Setting the Over Current Threshold Level

The OCP detection level (I<sub>ocp</sub>) is determined by the ON resistance (R<sub>ON</sub>) of the main MOSFET switch and the resistance (R<sub>cl</sub>) which is placed between CL and VCC.

$$I_{ocp} = \frac{R_{cl}}{R_{ON}} \times 10^{-5} \text{ [A]} \quad (\text{typ.})$$

To prevent a malfunction caused by noise, place a capacitor (C<sub>cl</sub>) parallel to R<sub>cl</sub>.

If OCP function is not needed, short VS to VCC, and short CL to GND.

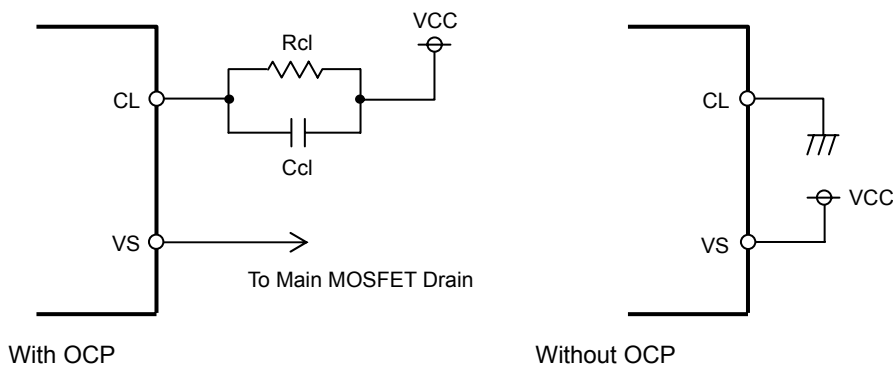

CL, VS Pin Connection

4)Setting the Time for Short Circuit Protection

The time (tscp) from output short to latch activation is determined by the capacitor, Cscp, connected SCP pin.

$$t_{scp} = 7.96 \times 10^5 \times C_{scp} \quad [\text{sec}] \quad (\text{typ.})$$

Short SCP to GND if SCP function is not being used.

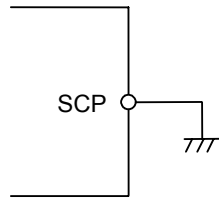

Without SCP

5)Single Channel Operation

This device can be used as a single output. The connection is as follows;

- DTC,FB,CTL,CL      —————> Short to GND
- VS,PVCC            —————> Short to VCC
- INV                    —————> Short to VREF

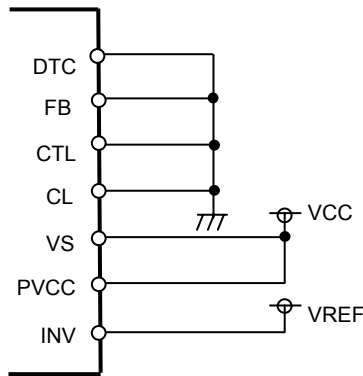

Single Channel Operation

6)Setting the Oscillating Frequency

The oscillating frequency can be set by selecting the timing resistor (RRT)and the timing capacitor (CCT).

Oscillating Frequency vs. Timing Capacitance (CCT)

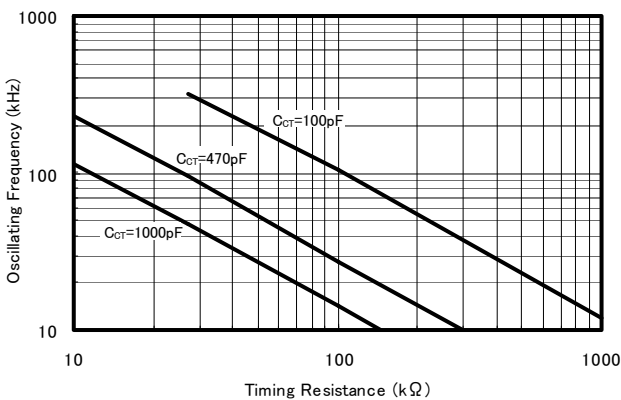

Fig.3

Oscillating Frequency vs. Timing Capacitance (RRT)

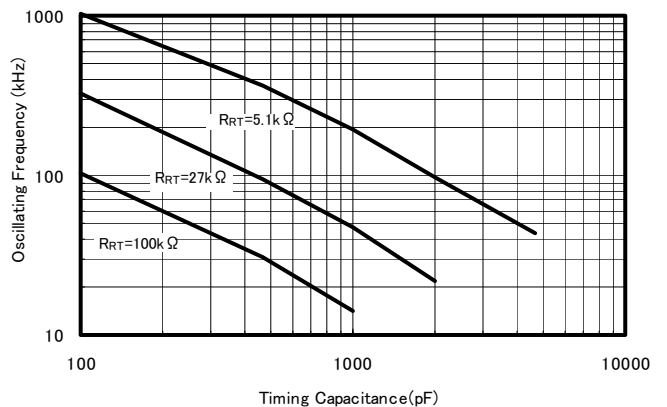

Fig.4



● Timing Chart (BD9775FV)

• Output ON/OFF, Minimum Input (UVLO)

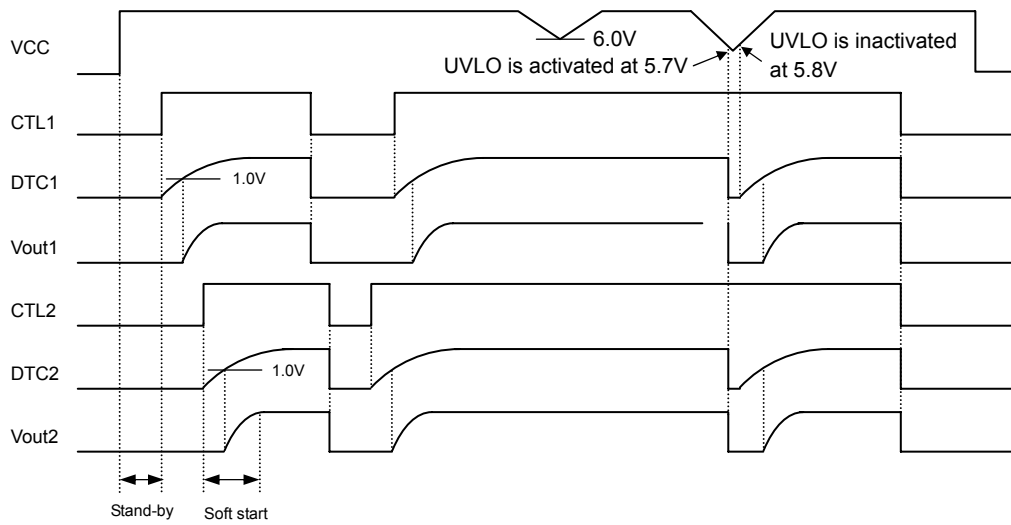

Fig.5

• Over Current Protection, Short Circuit Protection, Thermal Shut Down

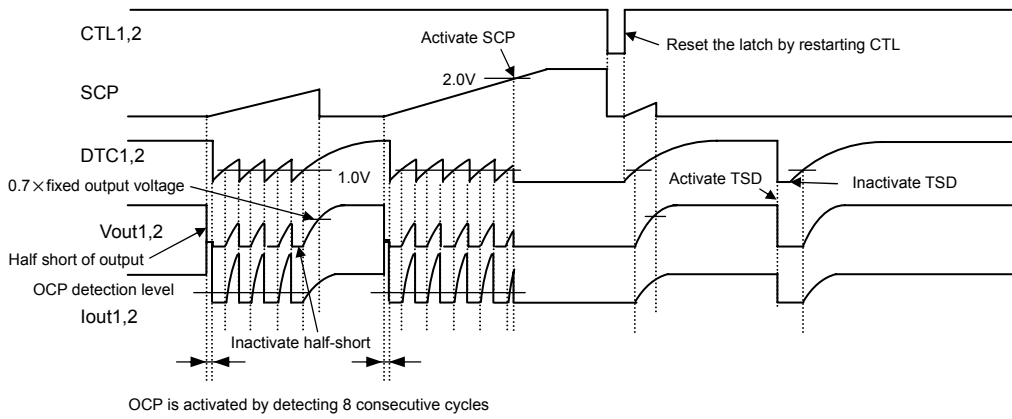

Fig.6

● I/O EQUIVALENT CIRCUIT (BD9775FV)

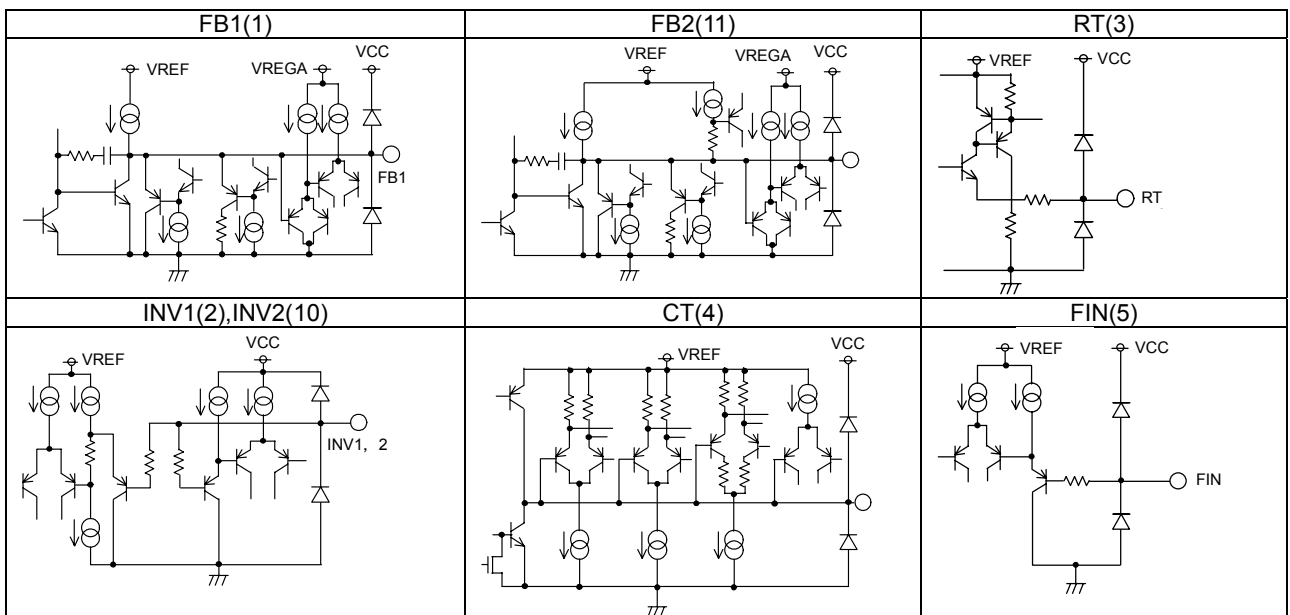

Fig.7

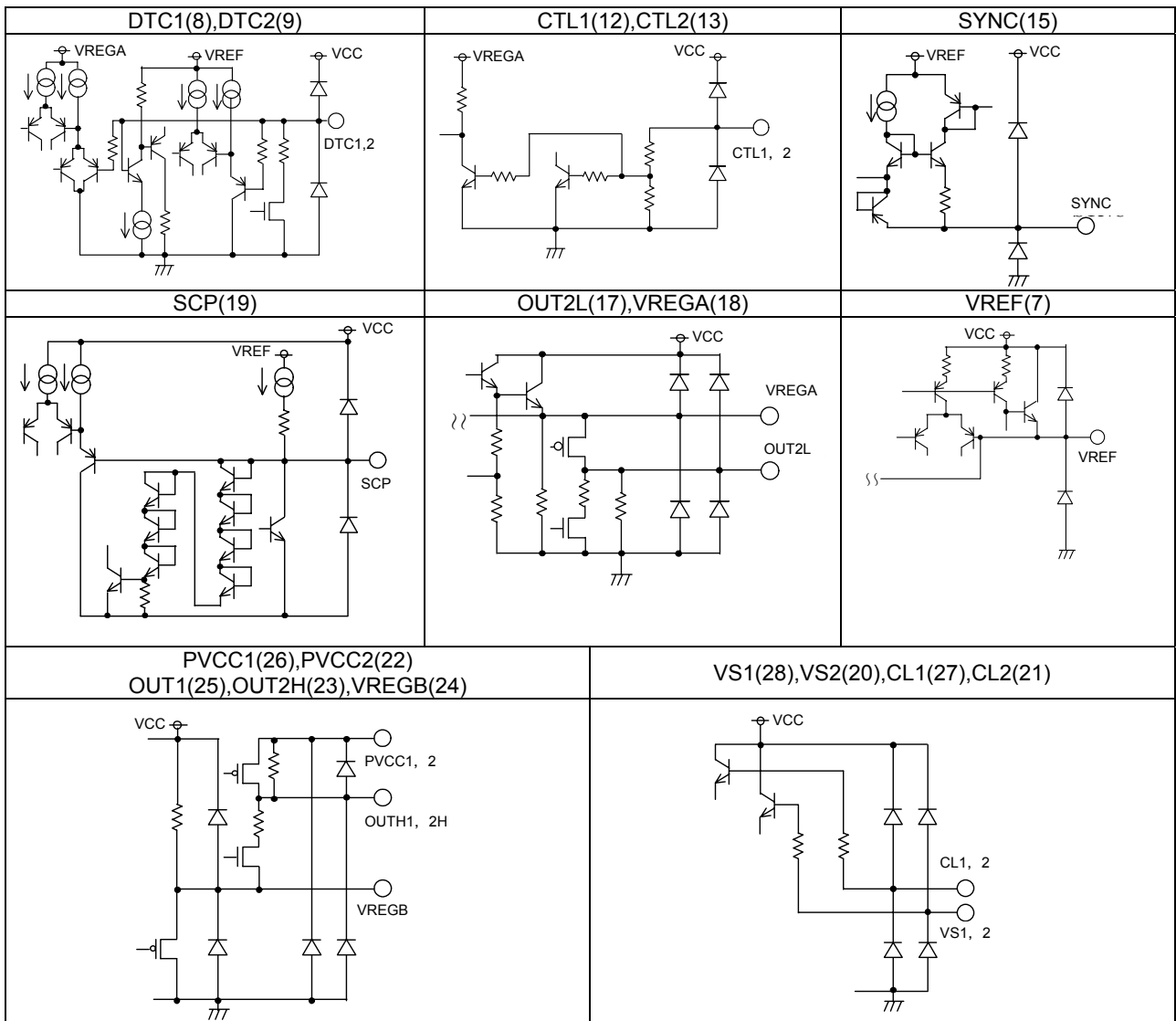

Fig.8

● Operation Notes (BD9775FV)

1) Absolute maximum ratings

Use of the IC in excess of absolute maximum ratings such as the applied voltage or operating temperature range may result in IC deterioration or damage. Assumptions should not be made regarding the state of the IC (short mode or open mode) when such damage is suffered. A physical safety measure such as a fuse should be implemented when use of the IC in a special mode where the absolute maximum ratings may be exceeded is anticipated.

2) GND potential

Ensure a minimum GND pin potential in all operating conditions. In addition, ensure that no pins other than the GND pin carry a voltage lower than or equal to the GND pin, including during actual transient phenomena.

3) Thermal design

Use a thermal design that allows for a sufficient margin in light of the power dissipation (Pd) in actual operating conditions.

4) Inter-pin shorts and mounting errors

Use caution when orienting and positioning the IC for mounting on printed circuit boards. Improper mounting may result in damage to the IC. Shorts between output pins or between output pins and the power supply and GND pin caused by the presence of a foreign object may result in damage to the IC.

5) Operation in a strong electromagnetic field

Use caution when using the IC in the presence of a strong electromagnetic field as doing so may cause the IC to malfunction.

6) Thermal shutdown circuit (TSD circuit)

This IC incorporates a built-in thermal shutdown circuit (TSD circuit). The TSD circuit is designed only to shut the IC off to prevent runaway thermal operation. Do not continue to use the IC after operating this circuit or use the IC in an environment where the operation of the thermal shutdown circuit is assumed.

7) Testing on application boards

When testing the IC on an application board, connecting a capacitor to a pin with low impedance subjects the IC to stress. Always discharge capacitors after each process or step. Ground the IC during assembly steps as an antistatic measure, and use similar caution when transporting or storing the IC. Always turn the IC's power supply off before connecting it to or removing it from a jig or fixture during the inspection process.

8) Common impedance

Power supply and ground wiring should reflect consideration of the need to lower common impedance and minimize ripple as much as possible (by making wiring as short and thick as possible or rejecting ripple by incorporating inductance and capacitance).

9) Applications with modes that reverse VCC and pin potentials may cause damage to internal IC circuits.

For example, such damage might occur when VCC is shorted with the GND pin while an external capacitor is charged.

It is recommended to insert a diode for preventing back current flow in series with VCC or bypass diodes between VCC and each pin.

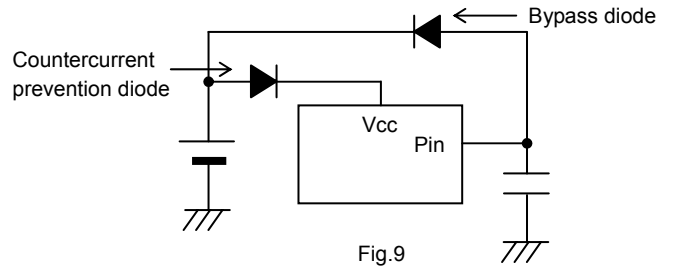

10) Timing resistor and capacitor

Timing resistor(capacitor) connected between RT(CT) and GND, has to be placed near RT(CT) terminal 3pin(4pin). And pattern has to be short enough.

VREF VCC

11) The Dead time input voltage has to be set more than 1.1V.

Also, the resistance between DTC and VREF is used more than 30kΩ to work OCP function reliably.

12) The energy on DTC1 (8pin) and DTC2 (9pin) is discharged when CTL1 (12pin) and CTL2 (13pin) are OFF, respectively, or VCC (14pin) is OFF (UVLO activation). However, it is considerable to occur overshoot when CTL and VCC are turned on with remaining more than 1V on the DTC.

13) If Gate capacitance of P-channel MOSFET or resistance placed on

Gate is large, and the time from beginning of Gate switching to the end of Drain's (tsw), is long, it may not start up due to the OCP malfunction.

To avoid it, select MOSFET or adjust resistance as tsw becomes less than 270nsec.

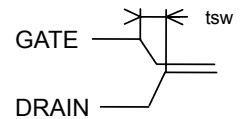

Fig.10

14) IC pin input

This monolithic IC contains P+ isolation and PCB layers between adjacent elements in order to keep them isolated.

P/N junctions are formed at the intersection of these P layers with the N layers of other elements to create a variety of parasitic elements.

For example, when a resistor and transistor are connected to pins as shown in following chart, the P/N junction functions as a parasitic diode when GND > (Pin A) for the resistor or GND > (Pin B) for the transistor (NPN).

Similarly, when GND > (Pin B) for the transistor (NPN), the parasitic diode described above combines with the N layer of other adjacent elements to operate as a parasitic NPN transistor.

The formation of parasitic elements as a result of the relationships of the potentials of different pins is an inevitable result of the IC's architecture. The operation of parasitic elements can cause interference with circuit operation as well as IC malfunction and damage. For these reasons, it is necessary to use caution so that the IC is not used in a way that will trigger the operation of parasitic elements, such as by the application of voltages lower than the GND (PCB) voltage to input and output pins.

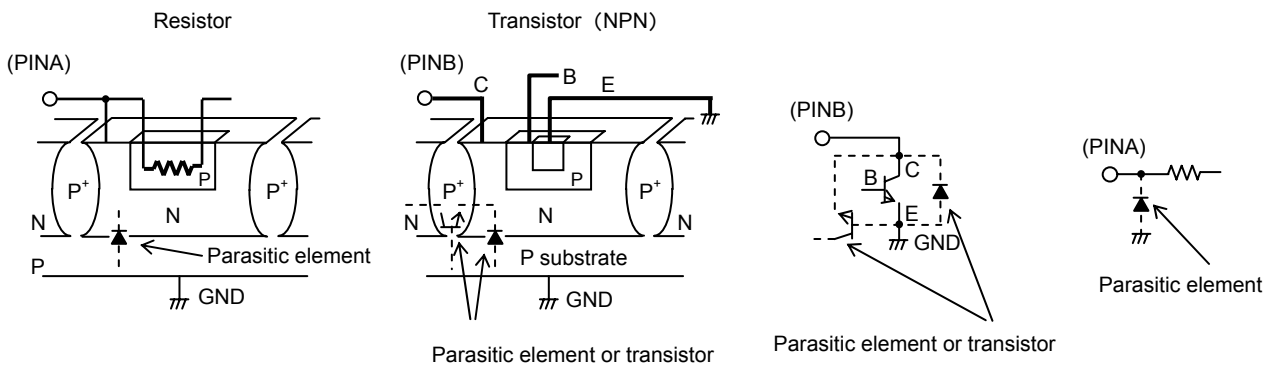

Fig.11

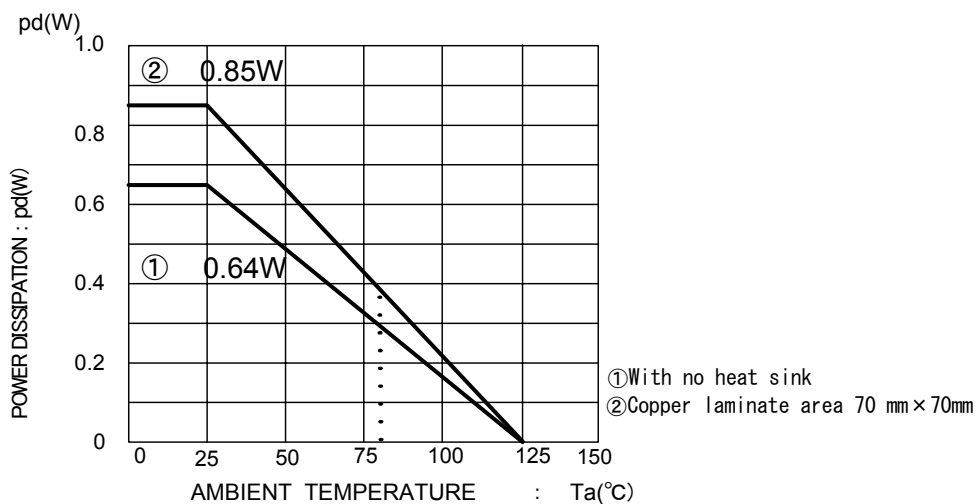

Fig.12

●Part order number

B	D
---	---

ROHM Part Code

9	7	7	5
---	---	---	---

Type/No.

F	V
---	---

Package type  
FV : SSOP-B28

E	2
---	---

Tape and Reel Information  
E2 : Embossed carrier tape

**SSOP-B28**

<Dimension>

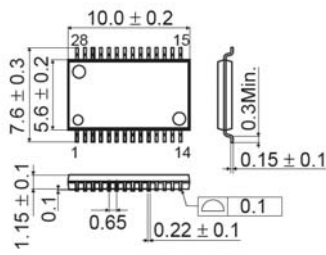

(Unit:mm)

<Tape and Reel information>

Tape	Embossed carrier tape
Quantity	2000pcs
Direction of feed	E2 (The direction is the 1pin of product is at the upper left when you hold reel on the left hand and you pull out the tape on the right hand)

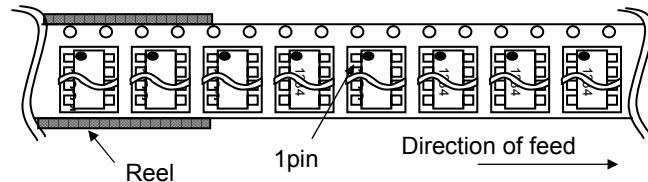

※When you order , please order in times the amount of package quantity.

- The contents described herein are correct as of September, 2008
- The contents described herein are subject to change without notice. For updates of the latest information, please contact and confirm with ROHM CO.,LTD.
- Any part of this application note must not be duplicated or copied without our permission.
- Application circuit diagrams and circuit constants contained herein are shown as examples of standard use and operation. Please pay careful attention to the peripheral conditions when designing circuits and deciding upon circuit constants in the set.
- Any data, including, but not limited to application circuit diagrams and information, described herein are intended only as illustrations of such devices and not as the specifications for such devices. ROHM CO.,LTD. disclaims any warranty that any use of such devices shall be free from infringement of any third party's intellectual property rights or other proprietary rights, and further, assumes no liability of whatsoever nature in the event of any such infringement, or arising from or connected with or related to the use of such devices.
- Upon the sale of any such devices, other than for buyer's right to use such devices itself, resell or otherwise dispose of the same, implied right or license to practice or commercially exploit any intellectual property rights or other proprietary rights owned or controlled by ROHM CO., LTD. is granted to any such buyer.
- The products described herein utilize silicon as the main material.
- The products described herein are not designed to be X ray proof.

The products listed in this catalog are designed to be used with ordinary electronic equipment or devices (such as audio visual equipment, office-automation equipment, communications devices, electrical appliances and electronic toys). Should you intend to use these products with equipment or devices which require an extremely high level of reliability and the malfunction of which would directly endanger human life (such as medical instruments, transportation equipment, aerospace machinery, nuclear-reactor controllers, fuel controllers and other safety devices), please be sure to consult with our sales representative in advance.

Contact us for further information about the products.

<b>San Diego</b>	TEL: +1-858-625-3630	FAX: +1-858-625-3670	<b>Tianjin</b>	TEL: +86-22-23029181	FAX: +86-22-23029183
<b>Atlanta</b>	TEL: +1-770-754-5972	FAX: +1-770-754-0691	<b>Shanghai</b>	TEL: +86-21-6279-2727	FAX: +86-21-6247-2066
<b>Boston</b>	TEL: +1-978-371-0382	FAX: +1-928-438-7164	<b>Hangzhou</b>	TEL: +86-571-87658072	FAX: +86-571-87658071
<b>Chicago</b>	TEL: +1-847-368-1006	FAX: +1-847-368-1008	<b>Nanjing</b>	TEL: +86-25-8689-0015	FAX: +86-25-8689-0393
<b>Dallas</b>	TEL: +1-469-287-5366	FAX: +1-469-362-7973	<b>Ningbo</b>	TEL: +86-574-87654201	FAX: +86-574-87654208
<b>Denver</b>	TEL: +1-303-708-0908	FAX: +1-303-708-0858	<b>Qingdao</b>	TEL: +86-532-5779-312	FAX: +86-532-5779-653
<b>Detroit</b>	TEL: +1-248-348-9920	FAX: +1-248-348-9942	<b>Suzhou</b>	TEL: +86-512-6807-1300	FAX: +86-512-6807-2300
<b>Nashville</b>	TEL: +1-615-620-6700	FAX: +1-615-620-6702	<b>Wuxi</b>	TEL: +86-510-82702693	FAX: +86-510-82702992
<b>Mexico</b>	TEL: +52-33-3123-2001	FAX: +52-33-3123-2002	<b>Shenzhen</b>	TEL: +86-755-8307-3008	FAX: +86-755-8307-3003
<b>Düsseldorf</b>	TEL: +49-2154-9210	FAX: +49-2154-921400	<b>Dongguan</b>	TEL: +86-769-8393-3320	FAX: +86-769-8398-4140
<b>Munich</b>	TEL: +49-8999-216168	FAX: +49-8999-216176	<b>Fuzhou</b>	TEL: +86-591-8801-8698	FAX: +86-591-8801-8690
<b>Stuttgart</b>	TEL: +49-711-7272-370	FAX: +49-711-7272-3720	<b>Guangzhou</b>	TEL: +86-20-3878-8100	FAX: +86-20-3825-5965
<b>France</b>	TEL: +33-1-5697-3060	FAX: +33-1-5697-3080	<b>Huizhou</b>	TEL: +86-752-205-1054	FAX: +86-752-205-1059
<b>United Kingdom</b>	TEL: +44-1-908-306700	FAX: +44-1-908-235788	<b>Xiamen</b>	TEL: +86-592-238-5705	FAX: +86-592-239-8380
<b>Denmark</b>	TEL: +45-3694-4739	FAX: +45-3694-4789	<b>Zhuhai</b>	TEL: +86-756-3232-480	FAX: +86-756-3232-460
<b>Espoo</b>	TEL: +358-9725-54491	FAX: +358-9-7255-4499	<b>Hong Kong</b>	TEL: +852-2-740-6262	FAX: +852-2-375-8971
<b>Salo</b>	TEL: +358-2-7332234	FAX: +358-2-7332237	<b>Taipei</b>	TEL: +886-2-2500-6956	FAX: +886-2-2503-2869
<b>Oulu</b>	TEL: +358-9-5372930	FAX: +358-8-5372931	<b>Kaohsiung</b>	TEL: +886-7-237-0881	FAX: +886-7-238-7332
<b>Barcelona</b>	TEL: +34-9375-24320	FAX: +34-9375-24410	<b>Singapore</b>	TEL: +65-6332-2322	FAX: +65-6332-5662
<b>Hungary</b>	TEL: +36-1-4719338	FAX: +36-1-4719339	<b>Philippines</b>	TEL: +63-2-807-6872	FAX: +63-2-809-1422
<b>Poland</b>	TEL: +48-22-5757213	FAX: +48-22-5757001	<b>Thailand</b>	TEL: +66-2-254-4890	FAX: +66-2-256-6334
<b>Russia</b>	TEL: +7-495-739-41-74	FAX: +7-495-739-41-74	<b>Kuala Lumpur</b>	TEL: +60-3-7958-8355	FAX: +60-3-7958-8377
<b>Seoul</b>	TEL: +82-2-8182-700	FAX: +82-2-8182-715	<b>Penang</b>	TEL: +60-4-2286453	FAX: +60-4-2286452
<b>Masan</b>	TEL: +82-55-240-6234	FAX: +82-55-240-6236	<b>Kyoto</b>	TEL: +81-75-365-1218	FAX: +81-75-365-1228
<b>Dalian</b>	TEL: +86-411-8230-8549	FAX: +86-411-8230-8537	<b>Yokohama</b>	TEL: +81-45-476-2290	FAX: +81-45-476-2295
<b>Beijing</b>	TEL: +86-10-8525-2483	FAX: +86-10-8525-2489			

Excellence in Electronics

# ROHM

## ROHM CO., LTD.

21 Saiin Mizosaki-cho, Ukyo-ku, Kyoto  
615-8585, Japan  
TEL: +81-75-311-2121 FAX: +81-75-315-0172  
URL <http://www.rohm.com>

Published by  
KTC LSI Development Headquarters  
LSI Business Promotion Group

### Notes

No copying or reproduction of this document, in part or in whole, is permitted without the consent of ROHM CO.,LTD.

The content specified herein is subject to change for improvement without notice.

The content specified herein is for the purpose of introducing ROHM's products (hereinafter "Products"). If you wish to use any such Product, please be sure to refer to the specifications, which can be obtained from ROHM upon request.

Examples of application circuits, circuit constants and any other information contained herein illustrate the standard usage and operations of the Products. The peripheral conditions must be taken into account when designing circuits for mass production.

Great care was taken in ensuring the accuracy of the information specified in this document. However, should you incur any damage arising from any inaccuracy or misprint of such information, ROHM shall bear no responsibility for such damage.

The technical information specified herein is intended only to show the typical functions of and examples of application circuits for the Products. ROHM does not grant you, explicitly or implicitly, any license to use or exercise intellectual property or other rights held by ROHM and other parties. ROHM shall bear no responsibility whatsoever for any dispute arising from the use of such technical information.

The Products specified in this document are intended to be used with general-use electronic equipment or devices (such as audio visual equipment, office-automation equipment, communication devices, electronic appliances and amusement devices).

The Products are not designed to be radiation tolerant.

While ROHM always makes efforts to enhance the quality and reliability of its Products, a Product may fail or malfunction for a variety of reasons.

Please be sure to implement in your equipment using the Products safety measures to guard against the possibility of physical injury, fire or any other damage caused in the event of the failure of any Product, such as derating, redundancy, fire control and fail-safe designs. ROHM shall bear no responsibility whatsoever for your use of any Product outside of the prescribed scope or not in accordance with the instruction manual.

The Products are not designed or manufactured to be used with any equipment, device or system which requires an extremely high level of reliability the failure or malfunction of which may result in a direct threat to human life or create a risk of human injury (such as a medical instrument, transportation equipment, aerospace machinery, nuclear-reactor controller, fuel-controller or other safety device). ROHM shall bear no responsibility in any way for use of any of the Products for the above special purposes. If a Product is intended to be used for any such special purpose, please contact a ROHM sales representative before purchasing.

If you intend to export or ship overseas any Product or technology specified herein that may be controlled under the Foreign Exchange and the Foreign Trade Law, you will be required to obtain a license or permit under the Law.

Thank you for your accessing to ROHM product informations.

More detail product informations and catalogs are available, please contact your nearest sales office.

**ROHM Customer Support System**

**THE AMERICAS / EUROPE / ASIA / JAPAN**

[www.rohm.com](http://www.rohm.com)

Contact us : [webmaster@rohm.co.jp](mailto:webmaster@rohm.co.jp)

