

# Product Document

# Easy Turn

[www.ams.com/AS5043](http://www.ams.com/AS5043)

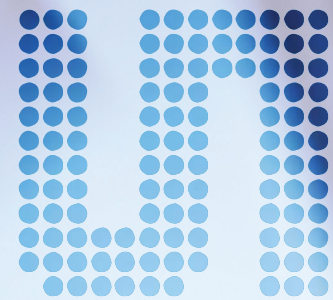

## AS5043 – Magnetic Rotary Position Sensor

- 10-bit Magnetic Rotary Position Sensor
- Absolute angle position via SSI readout
- Absolute angle position on analog output
- Zero position programmable

We provide innovative analog solutions to the most challenging applications in sensor and sensor interfaces, power management, and wireless.

## General Description

The AS5043 is a contactless magnetic angle position sensor for accurate measurement up to 360°. It is a system-on-chip, combining integrated Hall elements, analog front-end and digital signal processing in a single device. The AS5043 provides a digital 10-bit as well as a programmable analog output that is directly proportional to the angle of a magnet, rotating over the chip.

The analog output can be configured in many ways, including user programmable angular range, adjustable output voltage range, voltage or current output, etc. An internal voltage regulator allows operation of the AS5043 from 3.3V or 5.0V supplies.

### Applications

- Robotics and industrial automation
- Stepper motor position and motion control
- R/C Servo
- Valve control
- Front panel rotary switches
- Potentiometer replacement

### Features

- 360° contactless high resolution angular position sensing
- 10-bit versatile analog output
  - programmable angular range up to 360°
  - programmable ratiometric output voltage range
- Failure detection mode for magnet field strength
- Mode selection: input for optimizing noise vs. speed
- 3.3V or 5V compliant
- 16-pin SSOP package

### AS5043 Block Diagram

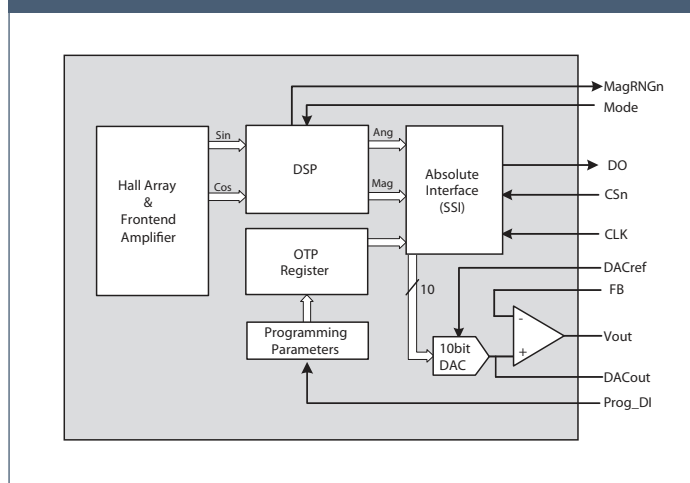

### Benefits

- Complete system-on-chip
- Absolute angle position via SSI readout and analog output
- User programmable zero position
- High reliability due to contactless sensing
- Immune to external magnetic stray fields
- Robust to misalignment, airgap variations, temperature variations and external magnetic stray fields