

PART NUMBER	REV	FIRST USED
466789-5	C	354500-1

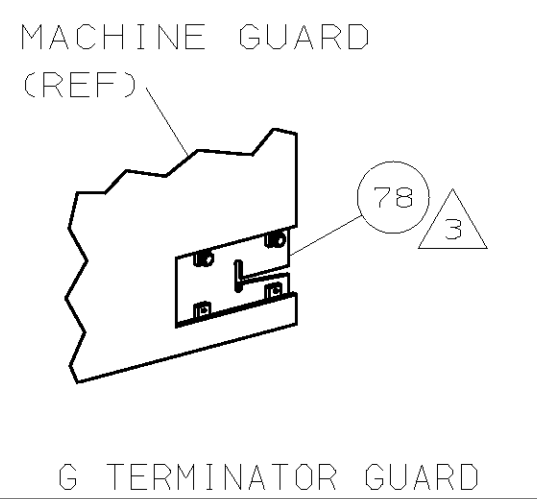

TERMINAL NAME: RECP,FASTON™ .250 PIDG					
PAD LTR	CRIMPING DATA		WIRE SIZE		
	CRIMP HEIGHT				
A	.096 ±.002 [2.44 ±0.05mm]		16-14		
B	NOT		USED		
C	NOT		USED		
D	NOT		USED		
CRIMP	SIZE	TYPE	RANGE		
WIRE	.222 [5.64mm]	-	16-14		
INSUL	.272 [6.91mm]	-	.160 MAX		
WIRE STRIP LENGTH	TERM APPL SPEC	FEED	APPL INSTRUCTION	SET UP GAGE	LAYOUT
-	114-1002	.450-.800		458637-1	1043

-5	BENCH MODEL G	MECH PRE FEED
----	---------------	---------------

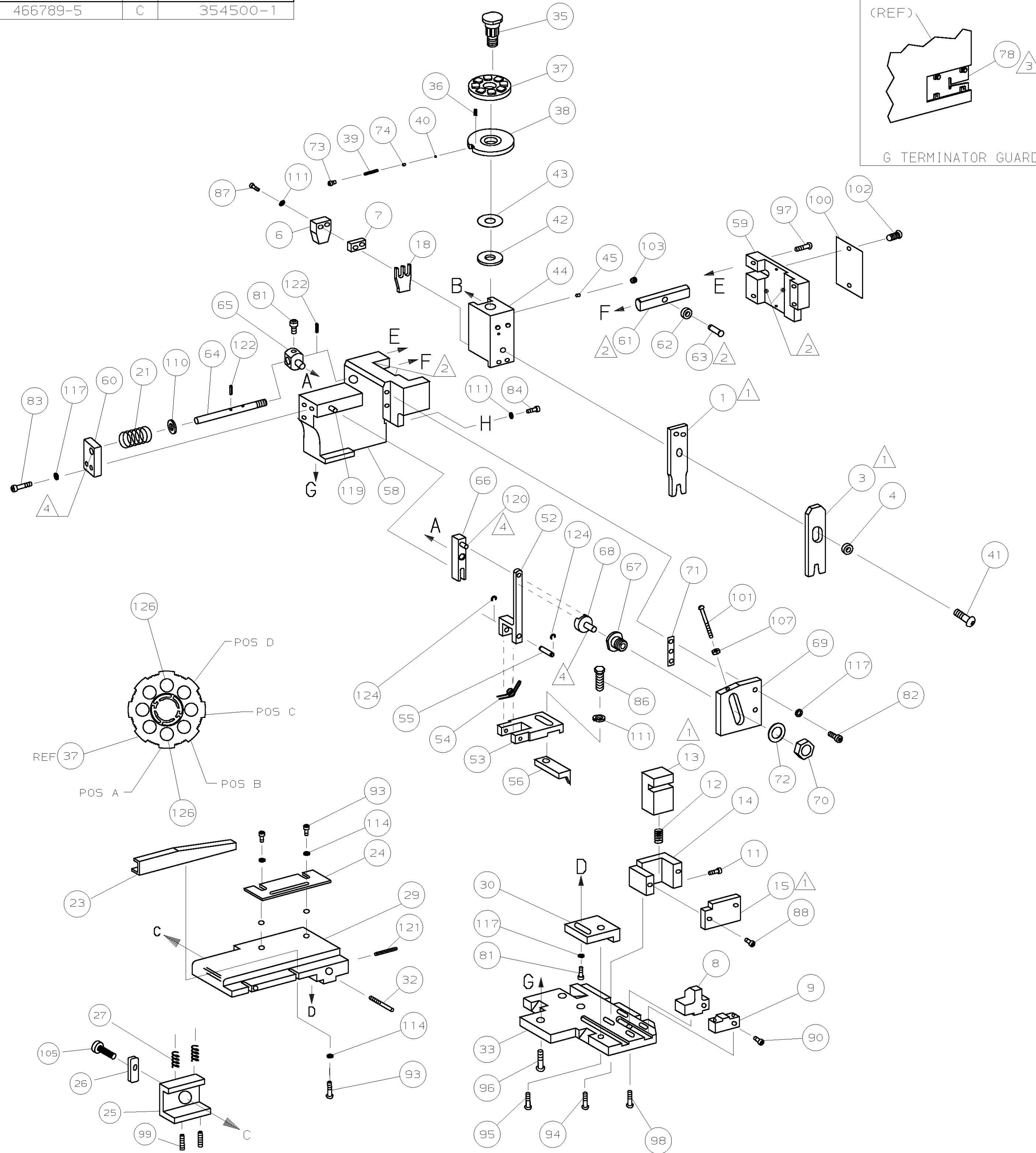

ITEM NO	QTY	REV	TERMINAL NAME	DESCRIPTION
129				
128				
127				
126				
125				
2	-	A	21045-3	RING, RET "C" (ø.187)FD FING PIN
124				
123				
2	-	A	5-21028-1	PIN, SLT SPR (ø.125x.50)ADJ ROD
1	-	A	4-21028-0	PIN, SLT SPR (ø.093x.75)ST GDE PL
122				
121				
1	-	A	1-21030-1	PIN, DOWEL (ø.187x.50)LEVER
1	-	A	1-21030-6	PIN, DOWEL (ø.187x1.25)HOUSING
120				
119				
118				
5	-	A	21024-5	WASHER, LOCK (#10)ADJ BLOCK
117				
116				
115				
2	-	A	21024-2	WASHER, LOCK (#4)FRONT STP GUIDE
114				
113				
112				
4	-	A	21024-4	WASHER, LOCK (#8)STRIPPER
111				
1	-	A	21899-4	WASHER, FLAT (ø5/16) SCREW ADJ
110				
109				
108				
1	-	A	21018-5	NUT, HEX (6-32)FEED ADJ
107				
106				
1	-	A	22353-8	SCR, SHLD (ø.187x.25)DRAG LEVER
105				
-	-	A	992031-1	PIN, CLEVIS
104				
1	-	A	21009-2	SCR, SKT SET (1/4-20x.25 LW)RAM
103				
2	-	A	21017-2	SCR, DRIVE (#2x.19)ID PLATE
102				
1	-	A	6-23715-5	SCR, PAN HD (6-32x1.50)FEED ADJ
101				
1	-	B	461264-1	PLATE, IDENTIFICATION
100				
2	-	A	5-21006-6	SCR, SET (10-32x.75)DRAG
99				
1	-	A	22733-8	SCR, BHC (8-32x.38 LW)ANVIL
98				
2	-	A	2-21002-9	SCR, BHC (10-32x.75)CAP
97				
3	-	A	2-22733-8	SCR, BHC (1/4-20x.62)HOUSING
96				
1	-	A	2-21002-7	SCR, BHC (10-32x.50)56 ADJ BLOCK
95				
2	-	A	2-21002-2	SCR, BHC (8-32x.50)TERM H DWN
94				
4	-	A	1-21000-4	SCR, BHC (8-32x.38)F STP GDE
93				
				92
1	-	A	1-21002-7	SCR, BHC (6-32x.38)CAM
91				
1	-	A	2-21000-8	SCR, SHC (8-32x.62 LW)ANVIL
90				
1	-	A	7-21000-9	SCR, SHC (4-40x.19)5TRIIPPER
89				
2	-	A	1-21002-6	SCR, SHC (6-32x.25)R SHEAR PLATE
88				
2	-	A	8-21002-9	SCR, BHC (8-32x1.00)DEP-HOLD
87				
1	-	A	2-22603-0	SCR, HEX HD (8-32x.31)FEED FINGER
86				
				85
1	-	A	2-21000-7	SCR, SHC (8-32x.50)STRIPPER
84				
2	-	A	3-21000-7	SCR, SHC (10-32x.75)FEED ROD GD
83				
2	-	A	3-21000-6	SCR, SHC (10-32x.62)FEED ADJ BLK
82				
2	-	A	3-21000-4	SCR, SHC (10-32x.38)56 ADJ BL
81				
				80
				79
				78
REF	-	B	679532-1	INSERT, GUARD
				77
				76
				75
1	-	A	690603-1	SPRING, ASSIST
74				
1	-	A	23030-1	SCR, SHC (6-32x.25 SL)INS DISC
73				
1	-	A	458109-1	WASHER, SPECIAL
72				
1	-	A	690517-1	SPACER
71				
				70
				69
				68
				67
				66
				65
				64
				63
				62
				61
				60
				59
				58
				57
				56
				55
				54
				53
				52
				51
				50
1	-	B	690602-6	CAM, PRE-FEED 1 5/8 ST
49				
48				
47				
46				
1	-	A	690191-1	PLUG, NYLON
45				
1	-	C	455673-1	RAM
44				
1	-	A	690125-1	WASHER, LAMINATED
43				
1	-	A	690124-1	WASHER, RAM
42				
1	-	A	7-21002-9	BOLT, CRIMPER (5/16x1.00)
41				
1	-	A	23241-6	BALL, STEEL
40				
1	-	A	690170-1	SPRING, COMPRESSION
39				
1	-	C	690142-1	DISC, INSULATION
38				
1	-	D	459663-4	WIRE DISC
37				
8	-	A	2-22280-5	SPRING, COMP
36				
1	-	B	690212-1	POST, RAM
35				
				34
1	-	D	455675-3	PLATE, BASE
33				
1	-	A	690432-3	SCREW, ADJUSTMENT
32				
				31
1	-	B	455689-1	BLOCK, STRIP GUIDE ADJ
30				
1	-	C	684045-1	PLATE, STRIP GUIDE
29				
				28
2	-	A	1-22284-0	SPRING, DRAG
27				
1	-	B	240793-4	LEVER, DRAG RELEASE
26				
1	-	B	240792-6	DRAG, TERMINAL
25				
1	-	D	690438-4	GUIDE, STRIP (REAR)
24				
1	-	A	684042-1	GUIDE, STRIP (FRONT)
23				
				22
				21
1	-	A	4-22284-9	SPRING, FEED RETURN
20				
1	-	A	679218-1	STRIPPER WIRE STOP ASSY
19				
1	-	B	458949-1	STRIPPER
18				
1	-	B	463460-1	HOLDER, TERMINAL
17				
				16
				15
1	-	B	690464-9	PLATE, SHEAR (REAR)
14				
1	-	B	690462-7	HOLDER, SHEAR (REAR)
13				
1	-	C	469542-1	SHEAR, FLOAT (REAR)
12				
1	-	A	5-22280-0	SPRING, SHEAR
11				
1	-	B	690461-2	STOP, SHEAR
10				
				9
1	-	C	1-454766-0	ANVIL, INSULATION
8				
1	-	C	467660-2	ANVIL
7				
1	-	C	1-240641-8	SPACER, DEPRESSOR (REAR)
6				
1	-	A	690468-6	DEPRESSOR, SHEAR (REAR)
5				
				4
1	-	B	238009-1	SPACER, BLOCK CRIMPER
3				
1	-	C	1-454765-2	CRIMPER, INSULATION
2				
				1
1	-	C	467661-2	CRIMPER, WIRE

ITEM NO	QTY	REV	TERMINAL NAME	DESCRIPTION
70				
69				
68				
67				
66				
65				
64				
63				
62				
61				
60				
59				
58				
57				
56				
55				
54				
53				
52				
51				
50				
49				
48				
47				
46				
45				
44				
43				
42				
41				
40				
39				
38				
37				
36				
35				
34				
33				
32				
31				
30				
29				
28				
27				
26				
25				
24				
23				
22				
21				
20				
19				
18				
17				
16				
15				
14				
13				
12				
11				
10				
9				
8				
7				
6				
5				
4				
3				
2				
1				

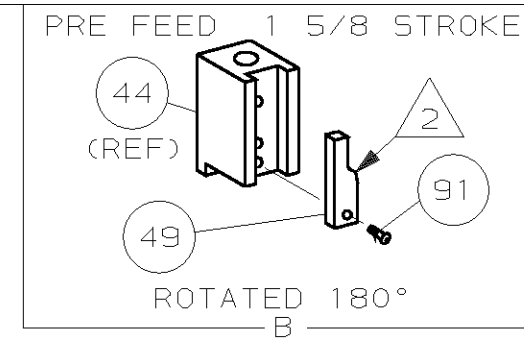

- 1 RECOMMENDED SPARE PARTS.
- 2 GREASE LIGHTLY.
- 3 GUARD MUST BE IN PLACE WHEN OPERATING APPLICATOR IN A BENCH MACHINE.
- 4 LUBRICATE DAILY USING NO. 20 MACHINE OIL.
- 5 USE ø.19 50/50 SOLDER TO CHECK CRIMP HEIGHT
- 6 CUT TO LENGTH AT ASSY

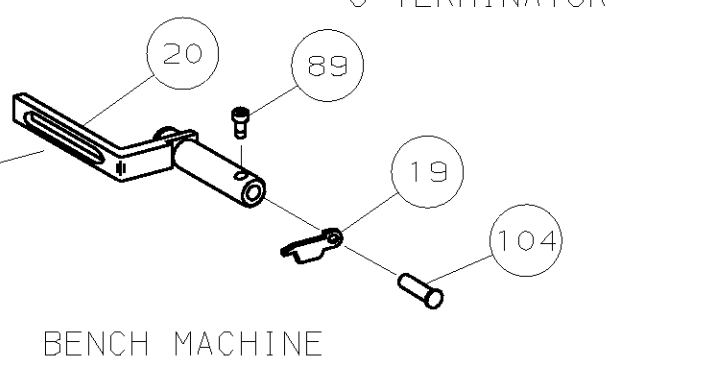

THIS DRAWING IS A CONTROLLED DOCUMENT

THIS DRAWING IS UNPUBLISHED. RELEASED FOR PUBLICATION APR 31, 1998 BY AMP INCORPORATED. ALL INTERNATIONAL RIGHTS RESERVED.

LOC A  
D1ST  
66

466789-5

D

C

B

A

C	ECN	0150-1194-04	TE	9-04
C	ECN	0150-1011-01	TE	10-01
B	0150-8412-98	TB	4-98	
A	REVISED	MO	9/95	
P/F	LTR	REVISION RECORD	APP	DATE

QTY REOD PER ASSY	PARTS LIST	ITEM NO
1	CRIMPER, WIRE	1
1	CRIMPER, INSULATION	2
1	SPACER, BLOCK CRIMPER	4
1	SPACER, DEPRESSOR (REAR)	7
1	ANVIL	8
1	ANVIL, INSULATION	9
1	STOP, SHEAR	11
1	SPRING, SHEAR	12
1	SHEAR, FLOAT (REAR)	13
1	HOLDER, SHEAR (REAR)	14
1	PLATE, SHEAR (REAR)	15
1	HOLDER, TERMINAL	18