

HI5735

12-Bit, 80 MSPS, High Speed Video D/A Converter

FN4133
 Rev 4.00
 May 2003

The HI5735 is a 12-bit, 80 MSPS, D/A converter which is implemented in the Intersil BiCMOS 10V (HBC-10) process. Operating from +5V and -5.2V, the converter provides -20.48mA of full scale output current and includes an input data register and bandgap voltage reference. Low glitch energy and excellent frequency domain performance are achieved using a segmented architecture. The digital inputs are TTL/CMOS compatible and translated internally to ECL. All internal logic is implemented in ECL to achieve high switching speed with low noise. The addition of laser trimming assures 12-bit linearity is maintained along the entire transfer curve.

Ordering Information

PART NUMBER	TEMP. RANGE (°C)	PACKAGE	PKG. NO.
HI5735KCB	0 to 70	28 Lead SOIC	M28.3

Features

- Throughput Rate 80 MSPS
- Low Power650mW
- Integral Linearity Error 0.75 LSB
- Low Glitch Energy3.0pV-s
- TTL/CMOS Compatible Inputs
- Improved Hold Time..... 0.25ns
- Excellent Spurious Free Dynamic Range

Applications

- Professional Video
- Cable TV Headend Equipment

Pinout

HI5735 (SOIC)
 TOP VIEW

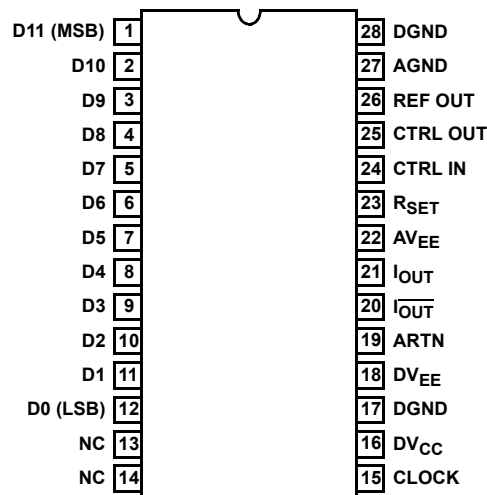

Typical Application Circuit

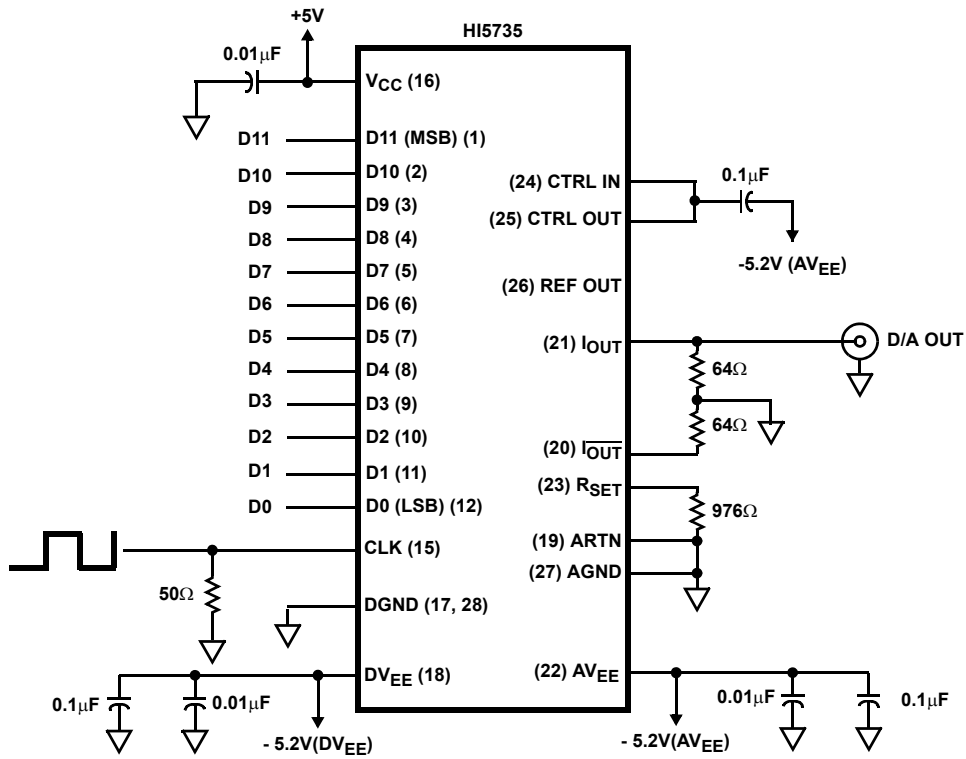

Functional Block Diagram

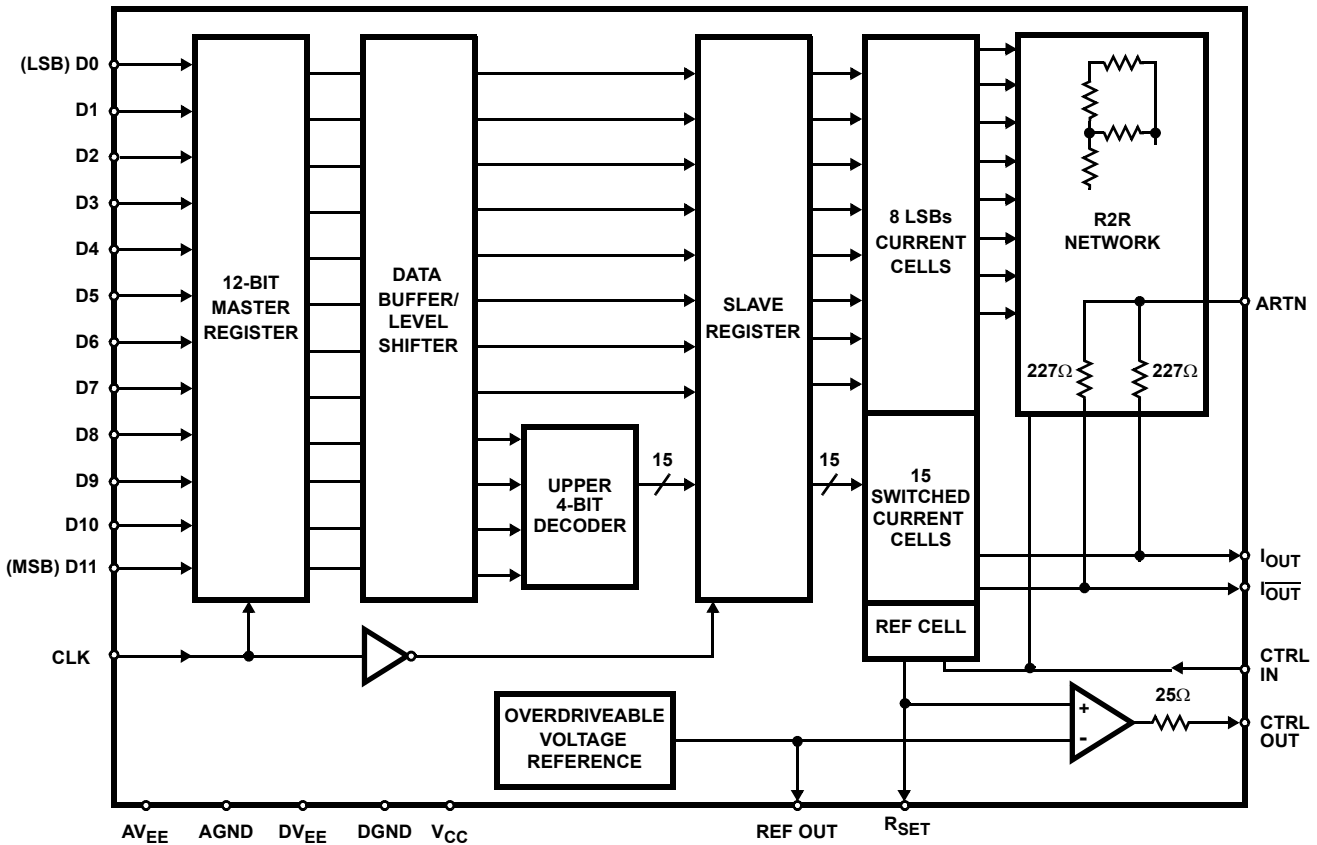

Absolute Maximum Ratings

Digital Supply Voltage V_{CC} to DGND	+5.5V
Negative Digital Supply Voltage DV_{EE} to DGND	-5.5V
Negative Analog Supply Voltage AV_{EE} to AGND, ARTN	-5.5V
Digital Input Voltages (D11-D0, CLK) to DGND	DV_{CC} to -0.5V
Internal Reference Output Current	± 2.5 mA
Voltage from CTRL IN to AV_{EE}	2.5V to 0V
Control Amplifier Output Current	± 2.5 mA
Reference Input Voltage Range	-3.7V to AV_{EE}
Analog Output Current (I_{OUT})	30mA

Thermal Information

Thermal Resistance (Typical, Note 1)	θ_{JA} ($^{\circ}$ C/W)
SOIC Package	75
Maximum Junction Temperature	
Plastic Packages	150 $^{\circ}$ C
Maximum Storage Temperature Range	-65 $^{\circ}$ C to 150 $^{\circ}$ C
Maximum Lead Temperature (Soldering 10s)	300 $^{\circ}$ C (SOIC - Lead Tips Only)

Operating Conditions

Temperature Range	
HI5735KCB	0 $^{\circ}$ C to 70 $^{\circ}$ C

CAUTION: Stresses above those listed in "Absolute Maximum Ratings" may cause permanent damage to the device. This is a stress only rating and operation of the device at these or any other conditions above those indicated in the operational sections of this specification is not implied.

NOTE:

- θ_{JA} is measured with the component mounted on an evaluation PC board in free air.

Electrical Specifications $AV_{EE}, DV_{EE} = -4.94$ to -5.46 V, $V_{CC} = +4.75$ to $+5.25$ V, $V_{REF} =$ Internal $T_A = 25^{\circ}$ C for All Typical Values

PARAMETER	TEST CONDITIONS	MIN	TYP	MAX	UNITS
SYSTEM PERFORMANCE					
Resolution		12	-	-	Bits
Integral Linearity Error, INL	(Note 4) ("Best Fit" Straight Line)	-	0.75	1.5	LSB
Differential Linearity Error, DNL	(Note 4)	-	0.5	1.0	LSB
Offset Error, I_{OS}	(Note 4)	-	20	75	μ A
Full Scale Gain Error, FSE	(Notes 2, 4)	-	1	10	%
Offset Drift Coefficient	(Note 3)	-	-	0.05	μ A/ $^{\circ}$ C
Full Scale Output Current, I_{FS}		-	20.48	-	mA
Output Voltage Compliance Range	(Note 3)	-1.25	-	0	V
DYNAMIC CHARACTERISTICS					
Throughput Rate	(Note 5)	80	-	-	MSPS
Output Voltage Full Scale Step Settling Time, t_{SETT} Full Scale	To ± 0.5 LSB Error Band $R_L = 50\Omega$ (Note 3)	-	20	-	ns
Single Glitch Area, GE (Peak)	$R_L = 50\Omega$ (Note 3)	-	5	-	pV-s
Doublet Glitch Area, (Net)		-	3	-	pV-s
Output Slew Rate	$R_L = 50\Omega$, DAC Operating in Latched Mode (Note 3)	-	1,000	-	V/ μ s
Output Rise Time	$R_L = 50\Omega$, DAC Operating in Latched Mode (Note 3)	-	675	-	ps
Output Fall Time	$R_L = 50\Omega$, DAC Operating in Latched Mode (Note 3)	-	470	-	ps
Differential Gain	$R_L = 50\Omega$ (Note 3)	-	0.15	-	%
Differential Phase	$R_L = 50\Omega$ (Note 3)	-	0.07	-	Deg
Spurious Free Dynamic Range to Nyquist (Note 3)	$f_{CLK} = 40$ MHz, $f_{OUT} = 2.02$ MHz, 20MHz Span	-	70	-	dBc
	$f_{CLK} = 80$ MHz, $f_{OUT} = 2.02$ MHz, 40MHz Span	-	70	-	dBc

Electrical Specifications $AV_{EE}, DV_{EE} = -4.94$ to $-5.46V$, $V_{CC} = +4.75$ to $+5.25V$, $V_{REF} = \text{Internal } T_A = 25^{\circ}C$ for All Typical Values

PARAMETER	TEST CONDITIONS	MIN	TYP	MAX	UNITS
REFERENCE/CONTROL AMPLIFIER					
Internal Reference Voltage, V_{REF}	(Note 4)	-1.27	-1.23	-1.17	V
Internal Reference Voltage Drift	(Note 3)	-	50	-	$\mu V/^{\circ}C$
Internal Reference Output Current Sink/Source Capability	(Note 3)	-125	-	+50	μA
Internal Reference Load Regulation	$I_{REF} = 0$ to $I_{REF} = -125\mu A$	-	50	-	μV
Input Impedance at REF OUT pin	(Note 3)	-	1.4	-	$k\Omega$
Amplifier Large Signal Bandwidth (0.6V _{p-p})	Sine Wave Input, to Slew Rate Limited (Note 3)	-	3	-	MHz
Amplifier Small Signal Bandwidth (0.1V _{p-p})	Sine Wave Input, to -3dB Loss (Note 3)	-	10	-	MHz
Reference Input Impedance	(Note 3)	-	12	-	$k\Omega$
Reference Input Multiplying Bandwidth (CTL IN)	$R_L = 50\Omega$, 100mV Sine Wave, to -3dB Loss at I_{OUT} (Note 3)	-	200	-	MHz
DIGITAL INPUTS (D9-D0, CLK, INVERT)					
Input Logic High Voltage, V_{IH}	(Note 4)	2.0	-	-	V
Input Logic Low Voltage, V_{IL}	(Note 4)	-	-	0.8	V
Input Logic Current, I_{IH}	(Note 4)	-	-	400	μA
Input Logic Current, I_{IL}	(Note 4)	-	-	700	μA
Digital Input Capacitance, C_{IN}	(Note 3)	-	3.0	-	pF
TIMING CHARACTERISTICS					
Data Setup Time, t_{SU}	See Figure 1 (Note 3)	3.0	2.0	-	ns
Data Hold Time, t_{HLD}	See Figure 1 (Note 3)	0.5	0.25	-	ns
Propagation Delay Time, t_{PD}	See Figure 1 (Note 3)	-	4.5	-	ns
CLK Pulse Width, t_{PW1} , t_{PW2}	See Figure 1 (Note 3)	3.0	-	-	ns
POWER SUPPLY CHARACTERISTICS					
I_{EEA}	(Note 4)	-	42	50	mA
I_{EED}	(Note 4)	-	70	85	mA
I_{CCD}	(Note 4)	-	13	20	mA
Power Dissipation	(Note 4)	-	650	-	mW
Power Supply Rejection Ratio	$V_{CC} \pm 5\%$, $V_{EE} \pm 5\%$	-	5	-	$\mu A/V$

NOTES:

- Gain Error measured as the error in the ratio between the full scale output current and the current through R_{SET} (typically 1.28mA). Ideally the ratio should be 16.
- Parameter guaranteed by design or characterization and not production tested.
- All devices are 100% tested at 25°C. 100% production tested at temperature extremes for military temperature devices, sample tested for industrial temperature devices.
- Dynamic Range must be limited to a 1V swing within the compliance range.

Timing Diagrams

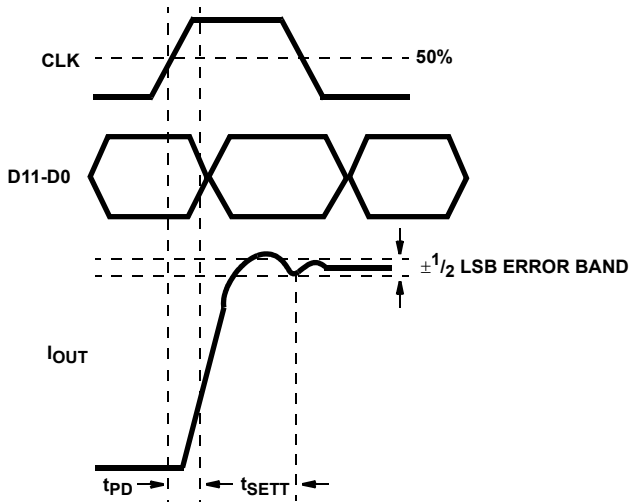

FIGURE 1. FULL SCALE SETTLING TIME DIAGRAM

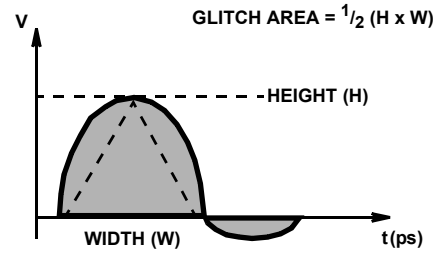

FIGURE 2. PEAK GLITCH AREA (SINGLET) MEASUREMENT METHOD

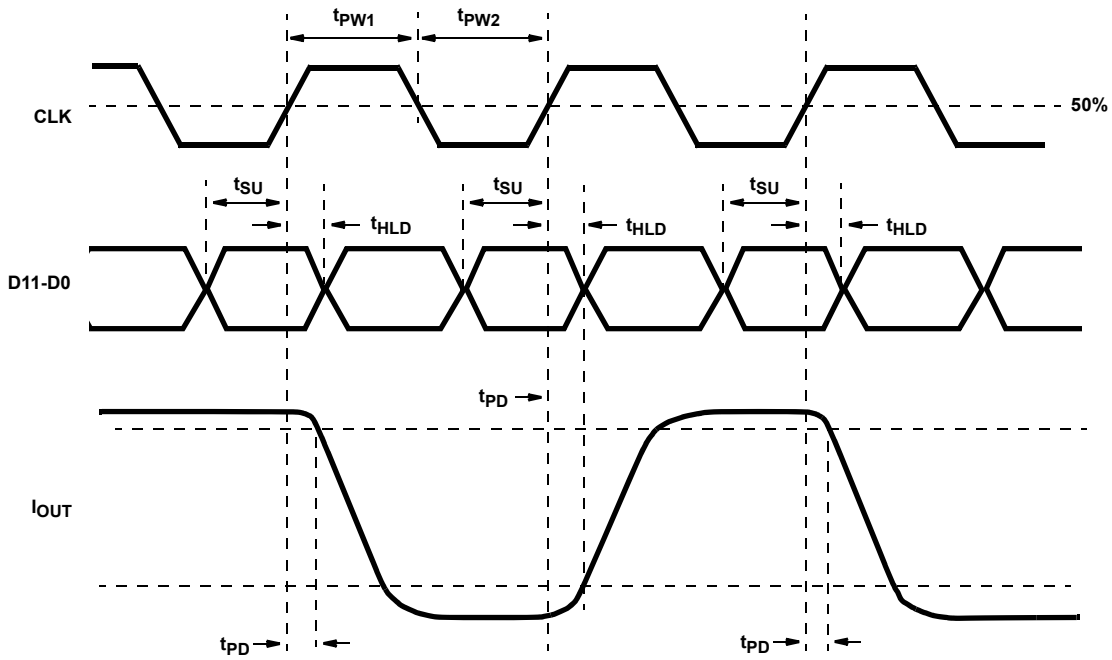

FIGURE 3. PROPAGATION DELAY, SETUP TIME, HOLD TIME AND MINIMUM PULSE WIDTH DIAGRAM

Typical Performance Curves

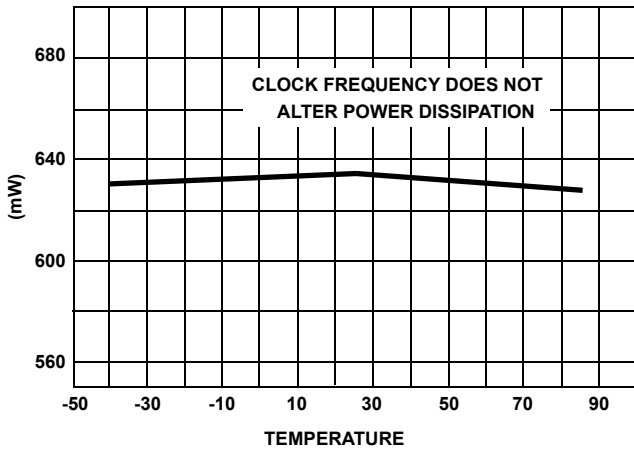

FIGURE 4. TYPICAL POWER DISSIPATION OVER TEMPERATURE

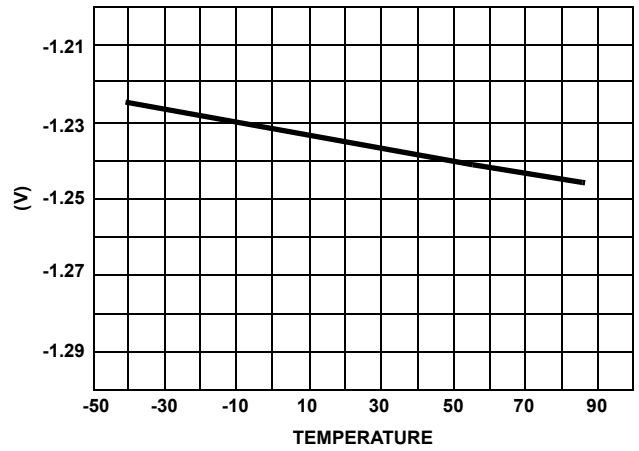

FIGURE 5. TYPICAL REFERENCE VOLTAGE OVER TEMPERATURE

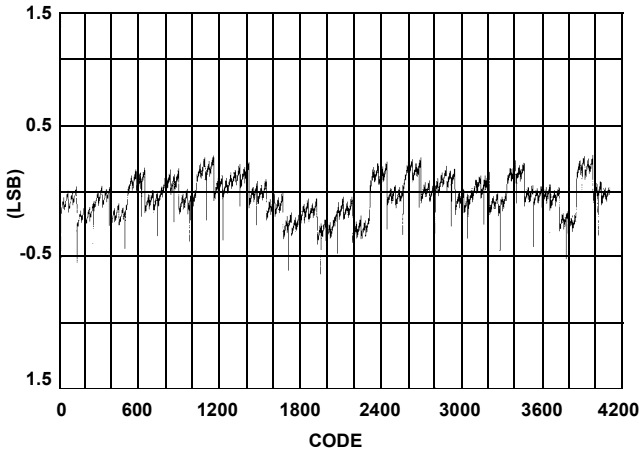

FIGURE 6. TYPICAL INL

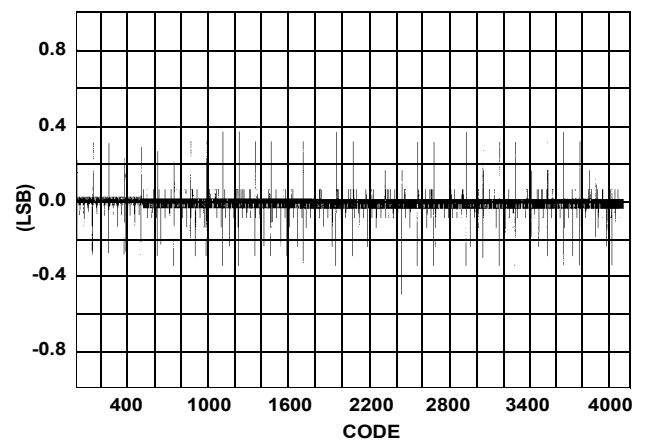

FIGURE 7. TYPICAL DNL

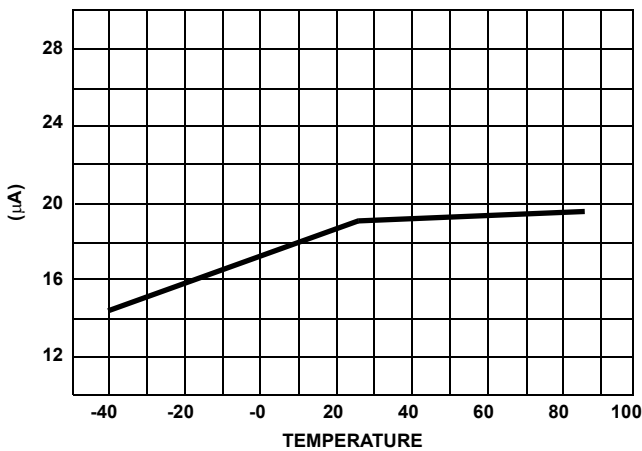

FIGURE 8. OFFSET CURRENT OVER TEMPERATURE

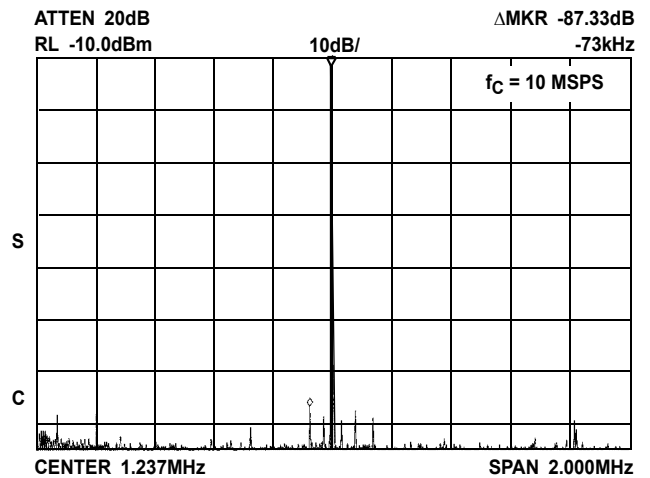

FIGURE 9. SPURIOUS FREE DYNAMIC RANGE = 87.3dBc

Pin Descriptions

PIN NUMBER	PIN NAME	PIN DESCRIPTION
1-12	D11 (MSB) thru D0 (LSB)	Digital Data Bit 11, the Most Significant Bit thru Digital Data Bit 0, the Least Significant Bit.
15	CLK	Data Clock Pin DC to 80 MSPS.
13, 14	NC	No Connect.
16	V _{CC}	Digital Logic Supply +5V.
17, 28	DGND	Digital Ground.
18	DV _{EE}	-5.2V Logic Supply.
23	R _{SET}	External resistor to set the full scale output current. $I_{FS} = 16 \times (V_{REF\ OUT} / R_{SET})$. Typically 976 Ω .
27	AGND	Analog Ground supply current return pin.
19	ARTN	Analog Signal Return for the R/2R ladder.
21	I _{OUT}	Current Output Pin.
20	I _{OUT}	Complementary Current Output Pin.
22	AV _{EE}	-5.2V Analog Supply.
24	CTRL IN	Input to the current source base rail. Typically connected to CTRL OUT and a 0.1 μ F capacitor to AV _{EE} . Allows external control of the current sources.
25	CTRL OUT	Control Amplifier Out. Provides precision control of the current sources when connected to CTRL IN such that $I_{FS} = 16 \times (V_{REF\ OUT} / R_{SET})$.
26	REF OUT	-1.23V (typical) bandgap reference voltage output. Can sink up to 125 μ A or be overdriven by an external reference capable of delivering up to 2mA.

Detailed Description

The HI5735 is a 12-bit, current out D/A converter. The DAC can convert at 80 MSPS and runs on +5V and -5.2V supplies. The architecture is an R/2R and segmented switching current cell arrangement to reduce glitch. Laser trimming is employed to tune linearity to true 12-bit levels. The HI5735 achieves its low power and high speed performance from an advanced BiCMOS process. The HI5735 consumes 650mW (typical) and has an improved hold time of only 0.25ns (typical).

Digital Inputs

The HI5735 is a TTL/CMOS compatible D/A. Data is latched by a Master register. Once latched, data inputs D0 (LSB) thru D11 (MSB) are internally translated from TTL to ECL. The internal latch and switching current source controls are implemented in ECL technology to maintain high switching speeds and low noise characteristics.

Decoder/Driver

The architecture employs a split R/2R ladder and Segmented Current source arrangement. Bits D0 (LSB) thru D7 directly drive a typical R/2R network to create the binary weighted current sources. Bits D8 thru D11 (MSB) pass thru a "thermometer" decoder that converts the incoming data into 15 individual segmented current source enables. This split architecture helps to improve glitch, thus resulting in a more constant glitch characteristic across the entire output transfer function.

Clocks and Termination

The internal 12-bit register is updated on the rising edge of the clock. Since the HI5735 clock rate can run to 80 MSPS, to minimize reflections and clock noise into the part, proper termination should be used. In PCB layout clock runs should be kept short and have a minimum of loads. To guarantee consistent results from board to board, controlled impedance PCBs should be used with a characteristic line impedance Z_0 of 50 Ω .

To terminate the clock line, a shunt terminator to ground is the most effective type at a 80 MSPS clock rate. A typical value for termination can be determined by the equation:

$$R_T = Z_0,$$

for the termination resistor. For a controlled impedance board with a Z_0 of 50 Ω , the $R_T = 50\Omega$. Shunt termination is best used at the receiving end of the transmission line or as close to the HI5735 CLK pin as possible.

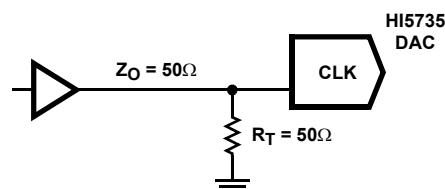

FIGURE 10. CLOCK LINE TERMINATION

Rise and Fall times and propagation delay of the line will be affected by the Shunt Terminator. The terminator should be connected to DGND.

Noise Reduction

To reduce power supply noise, separate analog and digital power supplies should be used with 0.1µF and 0.01µF ceramic capacitors placed as close to the body of the HI5735 as possible on the analog (AV_{EE}) and digital (DV_{EE}) supplies. The analog and digital ground returns should be connected together back at the device to ensure proper operation on power up. The V_{CC} power pin should also be decoupled with a 0.1µF capacitor.

Reference

The internal reference of the HI5735 is a -1.23V (typical) bandgap voltage reference with 50µV/°C of temperature drift (typical). The internal reference is connected to the Control Amplifier which in turn drives the segmented current cells. Reference Out (REF OUT) is internally connected to the Control Amplifier. The Control Amplifier Output (CTRL OUT) should be used to drive the Control Amplifier Input (CTRL IN) and a 0.1µF capacitor to analog V_{EE}. This improves settling time by providing an AC ground at the current source base node. The Full Scale Output Current is controlled by the REF OUT pin and the set resistor (R_{SET}). The ratio is:

$$I_{OUT} \text{ (Full Scale)} = (V_{REF \text{ OUT}}/R_{SET}) \times 16.$$

The internal reference (REF OUT) can be overdriven with a more precise external reference to provide better performance over temperature. Figure 11 illustrates a typical external reference configuration.

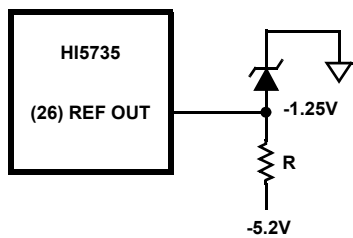

FIGURE 11. EXTERNAL REFERENCE CONFIGURATION

Outputs

The outputs I_{OUT} and I_{OUT} are complementary current outputs. Current is steered to either I_{OUT} or I_{OUT} in proportion to the digital input code. The sum of the two currents is always equal to the full scale current minus one LSB. The current output can be converted to a voltage by using a load resistor. Both current outputs should have the same load resistor (64Ω typically). By using a 64Ω load on the output, a 50Ω effective output resistance (R_{OUT}) is achieved due to the 227Ω (±15%) parallel resistance seen looking back into the output. This is the nominal value of the R2R ladder of the DAC. The 50Ω output is needed for matching the output with a 50Ω line. The load resistor should be chosen so that the effective output resistance (R_{OUT}) matches the line resistance.

The output voltage is:

$$V_{OUT} = I_{OUT} \times R_{OUT}.$$

I_{OUT} is defined in the reference section. I_{OUT} is not trimmed to 12 bits, so it is not recommended that it be used in conjunction with I_{OUT} in a differential-to-single-ended application. The compliance range of the output is from -1.25V to 0V, with a 1V_{P-P} voltage swing allowed within this range.

TABLE 2. INPUT CODING vs CURRENT OUTPUT

INPUT CODE (D11-D0)	I _{OUT} (mA)	I _{OUT} (mA)
1111 1111 1111	-20.48	0
1000 0000 0000	-10.24	-10.24
0000 0000 0000	0	-20.48

Settling Time

The settling time of the HI5735 is measured as the time it takes for the output of the DAC to settle to within a ±1/2 LSB error band of its final value during a full scale (code 0000... to 1111.... or 1111... to 0000...) transition. All claims made by Intersil with respect to the settling time performance of the HI5735 have been fully verified by the National Institute of Standards and Technology (NIST) and are fully traceable.

Glitch

The output glitch of the HI5735 is measured by summing the area under the switching transients after an update of the DAC. Glitch is caused by the time skew between bits of the incoming digital data. Typically, the switching time of digital inputs are asymmetrical, meaning that the turn off time is faster than the turn on time (TTL designs). Unequal delay paths through the device can also cause one current source to change before another. In order to minimize this, the Intersil HI5735 employs an internal register, just prior to the current sources, which is updated on the clock edge. Lastly, the worst case glitch on traditional D/A converters usually occurs at the major transition (i.e., code 2047 to 2048). However, due to the split architecture of the HI5735, the glitch is moved to the 255 to 256 transition (and every subsequent 256 code transitions thereafter). This split R/2R segmented current source architecture, which decreases the amount of current switching at any one time, makes the glitch practically constant over the entire output range. By making the glitch a constant size over the entire output range, this effectively integrates this error out of the end application.

In measuring the output glitch of the HI5735 the output is terminated into a 64Ω load. The glitch is measured at any one of the current cell carry (code 255 to 256 transition or any multiple thereof) throughout the DACs output range.

The glitch energy is calculated by measuring the area under the voltage-time curve. Figure 13 shows the area considered

as glitch when changing the DAC output. Units are typically specified in picoVolt-seconds (pV-s).

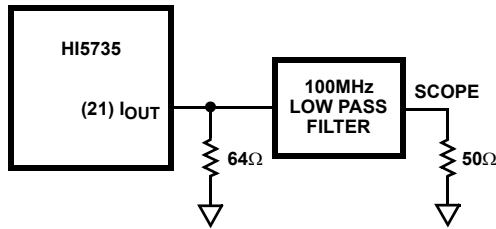

FIGURE 12. GLITCH TEST CIRCUIT

Applications

Bipolar Applications

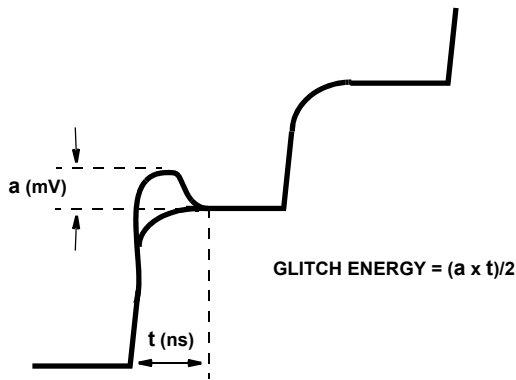

FIGURE 13. MEASURING GLITCH ENERGY

To convert the output of the HI5735 to a bipolar 4V swing, the following applications circuit is recommended. The reference can only provide 125µA of drive, so it must be buffered to create the bipolar offset current needed to generate the -2V output with all bits “off”. The output current must be converted to a voltage and then gained up and offset to produce the proper swing. Care must be taken to compensate for the voltage swing and error.

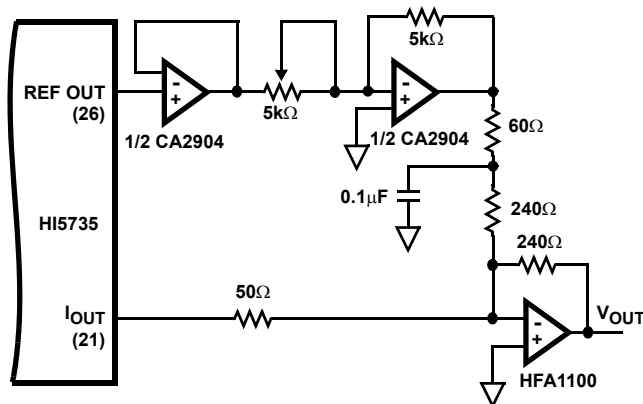

FIGURE 14. BIPOLAR OUTPUT CONFIGURATION

Definition of Specifications

Integral Linearity Error, INL, is the measure of the worst case point that deviates from a best fit straight line of data values along the transfer curve.

Differential Linearity Error, DNL, is the measure of the error in step size between adjacent codes along the converter’s transfer curve. Ideally, the step size is 1 LSB from one code to the next, and the deviation from 1 LSB is known as DNL. A DNL specification of greater than -1 LSB guarantees monotonicity.

Feedthru, is the measure of the undesirable switching noise coupled to the output.

Output Voltage Full Scale Settling Time, is the time required from the 50% point on the clock input for a full scale step to settle within an $\pm 1/2$ LSB error band.

Output Voltage Small Scale Settling Time, is the time required from the 50% point on the clock input for a 100mV step to settle within an $1/2$ LSB error band. This is used by applications reconstructing highly correlated signals such as sine waves with more than 5 points per cycle.

Glitch Area, GE, is the switching transient appearing on the output during a code transition. It is measured as the area under the curve and expressed as a picoVolt•Time specification (typically pV•s).

Differential Gain, ΔA_V , is the gain error from an ideal sine wave with a normalized amplitude.

Differential Phase, $\Delta\Phi$, is the phase error from an ideal sine wave.

Signal to Noise Ratio, SNR, is the ratio of a fundamental to the noise floor of the analog output. The first 5 harmonics are ignored, and an output filter of $1/2$ the clock frequency is used to eliminate alias products.

Total Harmonic Distortion, THD, is the ratio of the DAC output fundamental to the RMS sum of the harmonics. The first 5 harmonics are included, and an output filter of $1/2$ the clock frequency is used to eliminate alias products.

Spurious Free Dynamic Range, SFDR, is the amplitude difference from a fundamental to the largest harmonically or non-harmonically related spur. A sine wave is loaded into the D/A and the output filtered at $1/2$ the clock frequency to eliminate noise from clocking alias terms.

Intermodulation Distortion, IMD, is the measure of the sum and difference products produced when a two tone input is driven into the D/A. The distortion products created will arise at sum and difference frequencies of the two tones. IMD can be calculated using the following equation:

$$IMD = \frac{20 \text{Log} (\text{RMS of Sum and Difference Distortion Products})}{(\text{RMS Amplitude of the Fundamental})}$$

Die Characteristics

DIE DIMENSIONS:

161.5 mils x 160.7 mils x 19 mils ±1 mil

METALLIZATION:

Type: AlSiCu
 Thickness: M1 - 8kÅ, M2 - 17kÅ

PASSIVATION:

Type: Sandwich Passivation Undoped Silicon Glass (USG) + Nitride
 Thickness: USG - 8kÅ, Nitride - 4.2kÅ
 Total 12.2kÅ ± +2kÅ

DIE ATTACH:

Silver Filled Epoxy

SUBSTRATE POTENTIAL (POWERED UP):

V_{EED}

Metallization Mask Layout

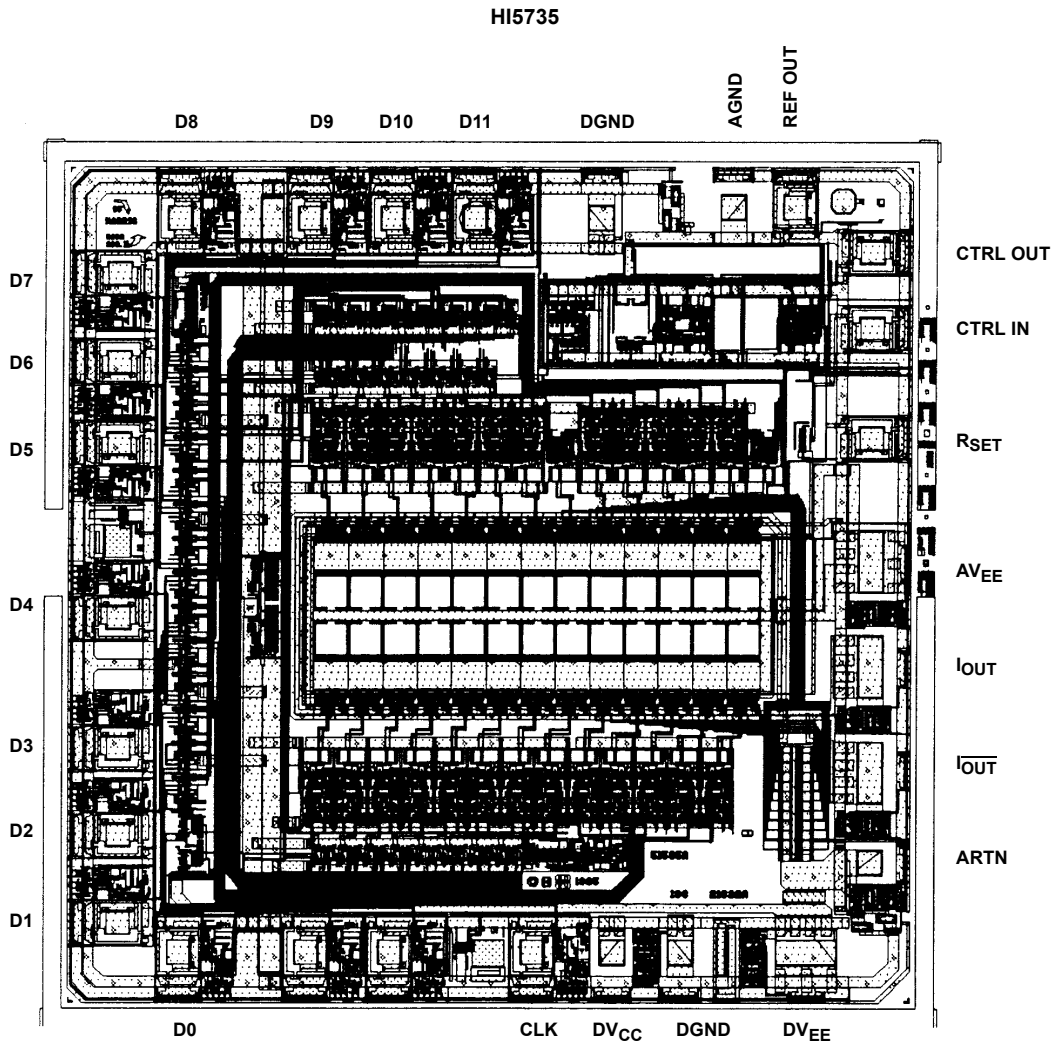

Small Outline Plastic Packages (SOIC)

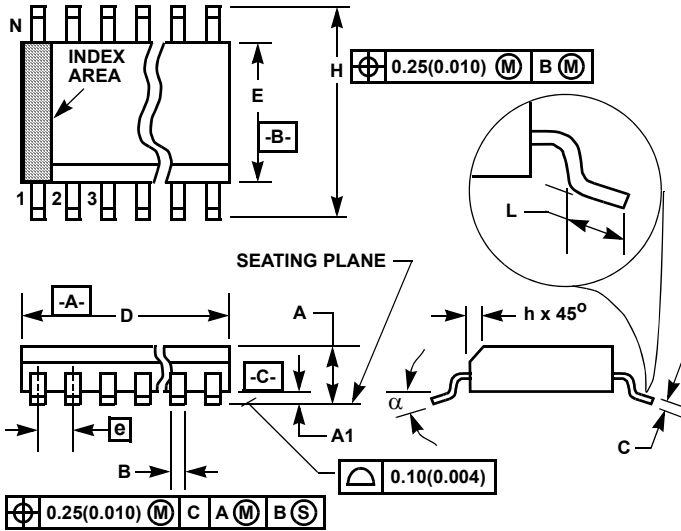

**M28.3 (JEDEC MS-013-AE ISSUE C)
28 LEAD WIDE BODY SMALL OUTLINE PLASTIC PACKAGE**

SYMBOL	INCHES		MILLIMETERS		NOTES
	MIN	MAX	MIN	MAX	
A	0.0926	0.1043	2.35	2.65	-
A1	0.0040	0.0118	0.10	0.30	-
B	0.013	0.0200	0.33	0.51	9
C	0.0091	0.0125	0.23	0.32	-
D	0.6969	0.7125	17.70	18.10	3
E	0.2914	0.2992	7.40	7.60	4
e	0.05 BSC		1.27 BSC		-
H	0.394	0.419	10.00	10.65	-
h	0.01	0.029	0.25	0.75	5
L	0.016	0.050	0.40	1.27	6
N	28		28		7
alpha	0°	8°	0°	8°	-

NOTES:

1. Symbols are defined in the "MO Series Symbol List" in Section 2.2 of Publication Number 95.
2. Dimensioning and tolerancing per ANSI Y14.5M-1982.
3. Dimension "D" does not include mold flash, protrusions or gate burrs. Mold flash, protrusion and gate burrs shall not exceed 0.15mm (0.006 inch) per side.
4. Dimension "E" does not include interlead flash or protrusions. Interlead flash and protrusions shall not exceed 0.25mm (0.010 inch) per side.
5. The chamfer on the body is optional. If it is not present, a visual index feature must be located within the crosshatched area.
6. "L" is the length of terminal for soldering to a substrate.
7. "N" is the number of terminal positions.
8. Terminal numbers are shown for reference only.
9. The lead width "B", as measured 0.36mm (0.014 inch) or greater above the seating plane, shall not exceed a maximum value of 0.61mm (0.024 inch)
10. Controlling dimension: MILLIMETER. Converted inch dimensions are not necessarily exact.

Rev. 0 12/93

© Copyright Intersil Americas LLC 2003. All Rights Reserved.

All trademarks and registered trademarks are the property of their respective owners.

For additional products, see www.intersil.com/en/products.html

Intersil products are manufactured, assembled and tested utilizing ISO9001 quality systems as noted in the quality certifications found at www.intersil.com/en/support/qualandreliability.html

Intersil products are sold by description only. Intersil may modify the circuit design and/or specifications of products at any time without notice, provided that such modification does not, in Intersil's sole judgment, affect the form, fit or function of the product. Accordingly, the reader is cautioned to verify that datasheets are current before placing orders. Information furnished by Intersil is believed to be accurate and reliable. However, no responsibility is assumed by Intersil or its subsidiaries for its use; nor for any infringements of patents or other rights of third parties which may result from its use. No license is granted by implication or otherwise under any patent or patent rights of Intersil or its subsidiaries.

For information regarding Intersil Corporation and its products, see www.intersil.com