



Precision Low Dropout Linear Controllers

FEATURES

- Precision 1% Reference
- Over-Current Sense Threshold Accurate to 5%
- Programmable Duty-Ratio Over-Current Protection
- 4.5V to 36V Operation
- 100mA Output Drive, Source or Sink
- Under-Voltage Lockout

Additional Features of the UC1832 series:

- Adjustable Current Limit to Current Sense Ratio
- Separate +VIN terminal
- Programmable Driver Current Limit
- Access to VREF and E/A(+)
- Logic-Level Disable Input

DESCRIPTION

The UC1832 and UC1833 series of precision linear regulators include all the control functions required in the design of very low dropout linear regulators. Additionally, they feature an innovative duty-ratio current limiting technique which provides peak load capability while limiting the average power dissipation of the external pass transistor during fault conditions. When the load current reaches an accurately programmed threshold, a gated-astable timer is enabled, which switches the regulator's pass device off and on at an externally programmable duty-ratio. During the on-time of the pass element, the output current is limited to a value slightly higher than the trip threshold of the duty-ratio timer. The constant-current-limit is programmable on the UCx832 to allow higher peak current during the on-time of the pass device. With duty-ratio control, high initial load demands and short circuit protection may both be accommodated without extra heat sinking or foldback current limiting. Additionally, if the timer pin is grounded, the duty-ratio timer is disabled, and the IC operates in constant-voltage/constant-current regulating mode.

These IC's include a 2 Volt ($\pm 1\%$) reference, error amplifier, UVLO, and a high current driver that has both source and sink outputs, allowing the use of either NPN or PNP external pass transistors. Safe operation is assured by the inclusion of under-voltage lockout (UVLO) and thermal shutdown.

The UC1833 family includes the basic functions of this design in a low-cost, 8-pin mini-dip package, while the UC1832 series provides added versatility with the availability of 14 pins. Packaging options include plastic (N suffix), or ceramic (J suffix). Specified operating temperature ranges are: commercial (0°C to 70°C), order UC3832/3 (N or J); industrial (-25°C to 85°C), order UC2832/3 (N or J); and military (-55°C to 125°C), order UC1832/3J. Surface mount packaging is also available.

BLOCK DIAGRAMS

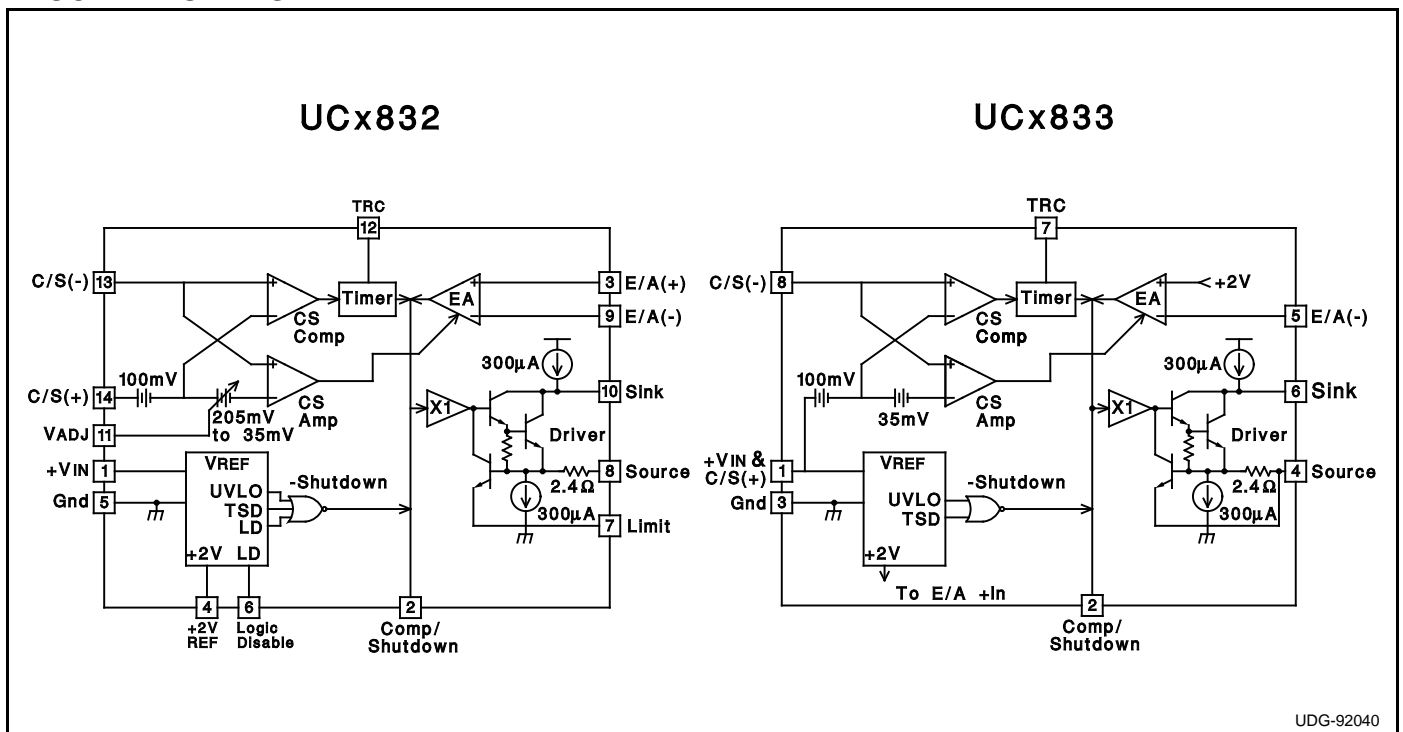

UDG-92040

ABSOLUTE MAXIMUM RATINGS

Supply Voltage +VIN	40V
Driver Output Current (Sink or Source)	450mA
Driver Sink to Source Voltage	40V
TRC Pin Voltage	-0.3V to 3.2V
Other Input Voltages	-0.3V to +VIN
Operating Junction Temperature (note 2)	-55°C to +150°C
Storage Temperature	-65°C to +150°C
Lead Temperature (Soldering, 10 Seconds)	300°C

Note 1: Unless otherwise indicated, voltages are referenced to ground and currents are positive into, negative out of, the specified terminals.

Note 2: See Unitorde Integrated Circuits databook for information regarding thermal specifications and limitations of packages.

CONNECTION DIAGRAMS

UC1832

**DIL-14 (Top View)
J Or N Package**

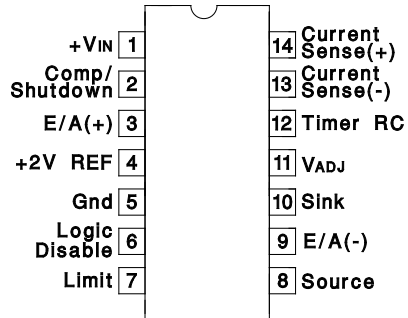

**SOIC-16 (Top View)
DW Package**

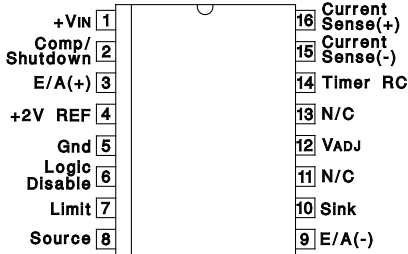

**LCC-20 & PLCC-20
L & Q Package
(Top View)**

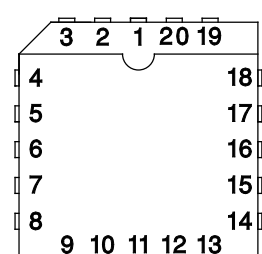

PACKAGE PIN FUNCTION	
FUNCTION	PIN
N/C	1
+VIN	2
Comp/Shutdown	3
E/A(+)	4
+2V REF	5
N/C	6
Gnd	7
Logic Disable	8
Limit	9
Source	10
N/C	11
E/A(-)	12
Sink	13
VADJ	14
N/C	15-17
Timer RC	18
Current Sense(-)	19
Current Sense(+)	20

UC1833

**DIL-8 (Top View)
J Or N Package**

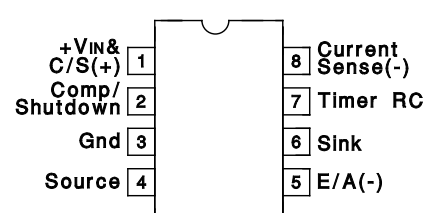

**SOIC-16 (Top View)
DW Package**

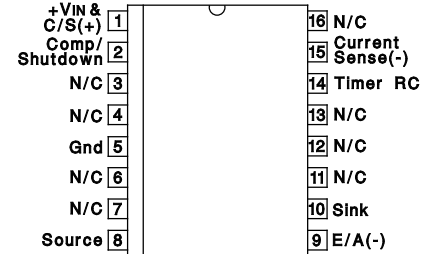

**LCC-20 & PLCC-20
L & Q Package
(Top View)**

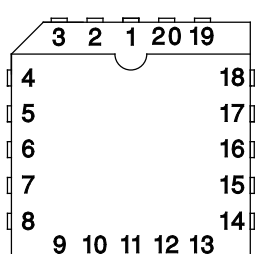

PACKAGE PIN FUNCTION	
FUNCTION	PIN
+VIN & C/S(+)	1
Comp/Shutdown	2
N/C	3
N/C	4
Gnd	5
N/C	6
N/C	7
Source	8
E/A(-)	9
Sink	10
N/C	11
N/C	12
N/C	13
Sink	14
Timer RC	15
Current Sense(+)	16
N/C	17-20

ELECTRICAL CHARACTERISTICS: Unless otherwise stated, specifications hold for $T_A = 0^\circ\text{C}$ to 70°C for the UC3832/3, -25°C to 85°C for the UC2832/3, and -55°C to 125°C for the UC1832/3, $+V_{IN} = 15\text{V}$, Driver sink = $+V_{IN}$, C/S(+) voltage = $+V_{IN}$. $T_A = T_J$.

PARAMETER	TEST CONDITIONS	MIN	TYP	MAX	UNITS
Input Supply					
Supply Current	$+V_{IN} = 6\text{V}$		6.5	10	mA
	$+V_{IN} = 36\text{V}$		9.5	15	mA
	Logic Disable = 2V (UCx832 only)		3.3		mA
Reference Section					
Output Voltage (Note 3)	$T_J = 25^\circ\text{C}$, $I_{DRIVER} = 10\text{mA}$	1.98	2.00	2.02	V
	over temperature, $I_{DRIVER} = 10\text{mA}$	1.96	2.00	2.04	V
Load Regulation (UCx832 only)	$I_{OUT} = 0$ to 10mA	-10	-5.0		mV
Line Regulation	$+V_{IN} = 4.5$ to 36V , $I_{DRIVER} = 10\text{mA}$		0.033	0.5	mV/V
Under-Voltage Lockout Threshold			3.6	4.5	V
Logic Disable Input (UCx832 only)					
Threshold Voltage		1.3	1.4	1.5	V
Input Bias Current	Logic Disable = 0V	-5.0	-1.0		μA
Current Sense Section					
Comparator Offset		95	100	105	mV
	Over Temperature	93	100	107	mV
Amplifier Offset (UCx833 only)		110	135	170	mV
Amplifier Offset (UCx832 only)	$V_{ADJ} = \text{Open}$	110	135	170	mV
	$V_{ADJ} = 1\text{V}$	180	235	290	mV
	$V_{ADJ} = 0\text{V}$	250	305	360	mV
Input Bias Current	$V_{CM} = +V_{IN}$	65	100	135	μA
Input Offset Current (UCx832 only)	$V_{CM} = +V_{IN}$	-10		10	μA
Amplifier CMRR (UCx832 only)	$V_{CM} = 4.1\text{V}$ to $+V_{IN} + 0.3\text{V}$		80		dB
Transconductance	$I_{COMP} = \pm 100\mu\text{A}$		65		mS
V_{ADJ} Input Current (UCx832 only)	$V_{ADJ} = 0\text{V}$	-10	-1		μA
Timer					
Inactive Leakage Current	C/S(+) = C/S(-) = $+V_{IN}$; TRC pin = 2V		0.25	1.0	μA
Active Pullup Current	C/S(+) = $+V_{IN}$, C/S(-) = $+V_{IN} - 0.4\text{V}$; TRC pin = 0V	-345	-270	-175	μA
Duty Ratio (note 4)	ontime/period, $R_T = 200\text{k}$, $C_T = 0.27\mu\text{F}$		4.8		%
Period (notes 4,5)	ontime + offtime, $R_T = 200\text{k}$, $C_T = 0.27\mu\text{F}$		36		ms
Upper Trip Threshold (V_U)			1.8		V
Lower Trip Threshold (V_L)			0.9		V
Trip Threshold Ratio	V_U/V_L		2.0		V/V
Error Amplifier					
Input Offset Voltage (UCx832 only)	$V_{CM} = V_{COMP} = 2\text{V}$	-8.0		8.0	mV
Input Bias Current	$V_{CM} = V_{COMP} = 2\text{V}$	-4.5	-1.1		μA
Input Offset Current (UCx832 only)	$V_{CM} = V_{COMP} = 2\text{V}$	-1.5		1.5	μA
AVOL	$V_{COMP} = 1\text{V}$ to 13V	50	70		dB
CMRR (UCx832 only)	$V_{CM} = 0\text{V}$ to $+V_{IN} - 3\text{V}$	60	80		dB
PSRR (UCx832 only)	$V_{CM} = 2\text{V}$, $+V_{IN} = 4.5$ to 36V		90		dB
Transconductance	$I_{COMP} = \pm 10\mu\text{A}$		4.3		mS
VOH	$I_{COMP} = 0$, Volts below $+V_{IN}$.95	1.3	V
VOL	$I_{COMP} = 0$.45	0.7	V
IOH	$V_{COMP} = 2\text{V}$	-700	-500	-100	μA

APPLICATION AND OPERATION INFORMATION (cont.)

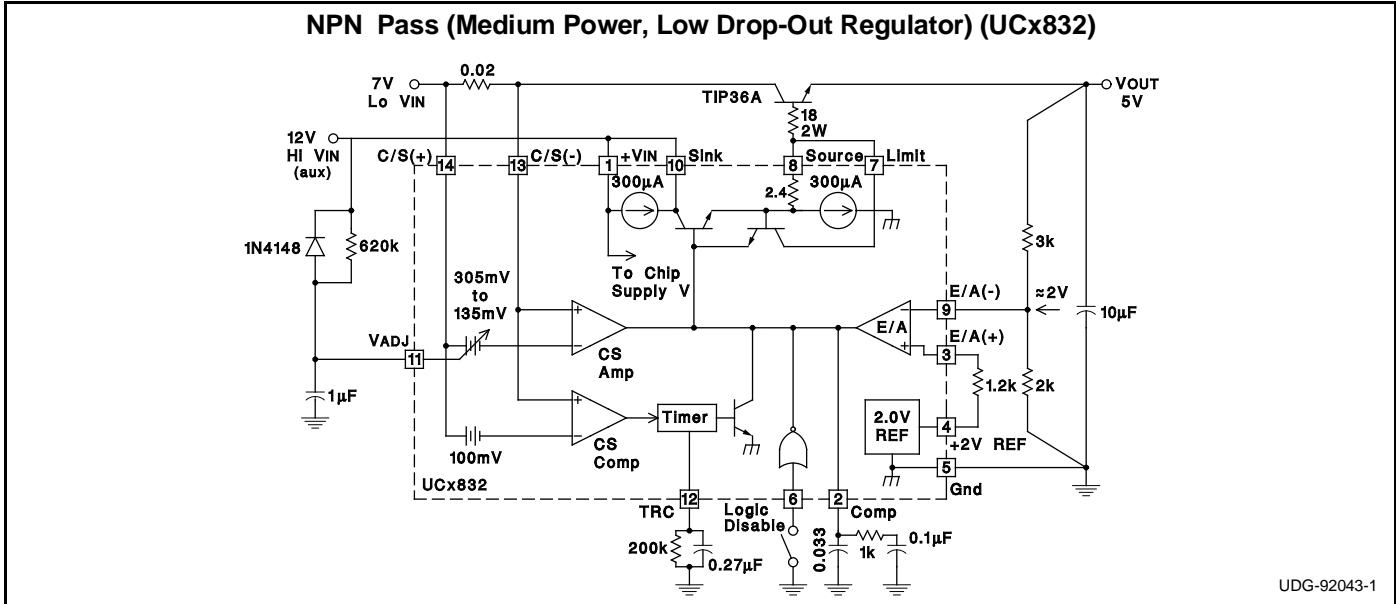
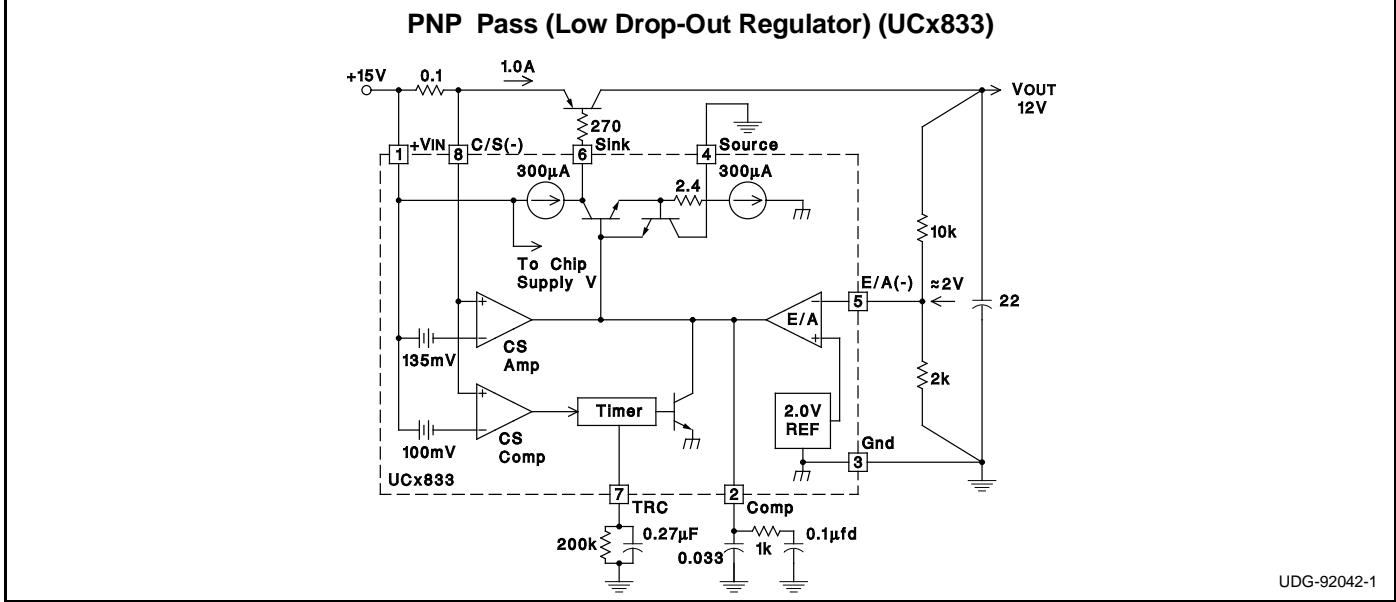

Estimating Maximum Load Capacitance

For any power supply, the rate at which the total output capacitance can be charged depends on the maximum output current available and on the nature of the load. For a constant-current current-limited power supply, the output will come up if the load asks for less than the maximum available short-circuit limit current.

To guarantee recovery of a duty-ratio current-limited power supply from a short-circuited load condition, there is a maximum total output capacitance which can be charged for a given unit ON time. The design value of ON time can be adjusted by changing the timing capacitor. Nominally, $T_{ON} = 0.693 \times 10k \times C_T$.

Typically, the IC regulates output current to a maximum of $I_{MAX} = K \times I_{TH}$, where I_{TH} is the timer trip-point current,

and
$$K = \frac{\text{Current Sense Amplifier Offset Voltage}}{100mA}$$

≈ 1.35 for UCx833, and is variable from 1.35 to 3.05 with VADJ for the UCx832.

For a worst-case constant-current load of value just less than I_{TH} , C_{MAX} can be estimated from:

$$C_{MAX} = ((K-1)I_{TH}) \left(\frac{T_{ON}}{V_{OUT}} \right),$$

where V_{OUT} is the nominal regulator output voltage.

For a resistive load of value R_L , the value of C_{MAX} can be estimated from:

$$C_{MAX} = \frac{T_{ON}}{R_L} \cdot \frac{1}{\ln \left[\left(1 - \frac{V_{OUT}}{K \cdot I_{TH} \cdot R_L} \right)^{-1} \right]}$$

APPLICATION AND OPERATION INFORMATION (cont.)

Current Sense Amplifier Offset Voltage vs VADJ

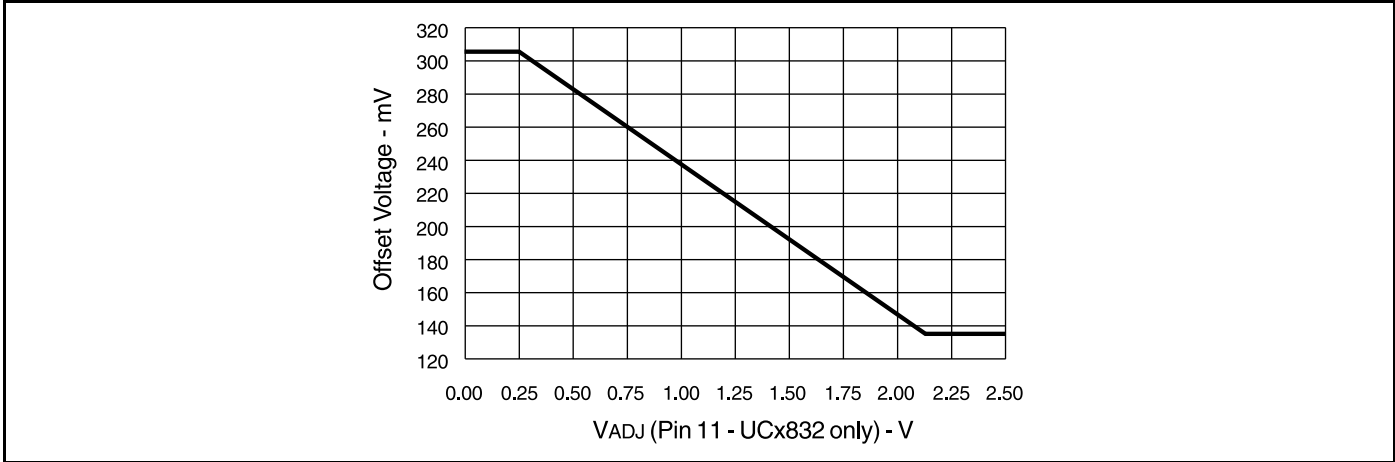

UCx832/33 Timer Function

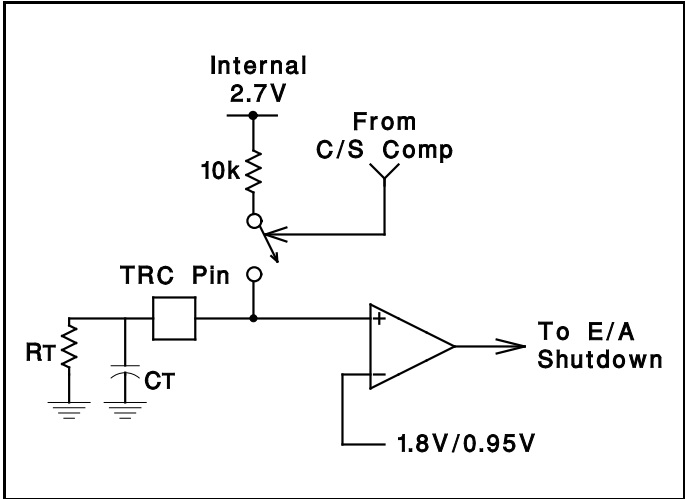

UCx832/33 Current Sense Input Configuration

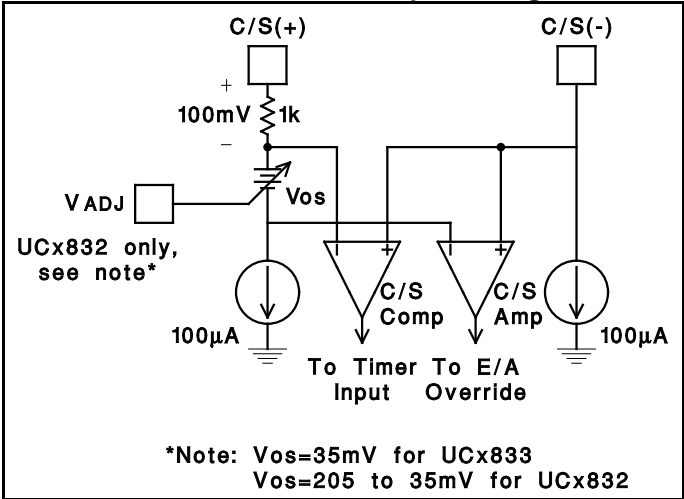

Load current, timing capacitor voltage, and output voltage of the regulator under fault conditions.

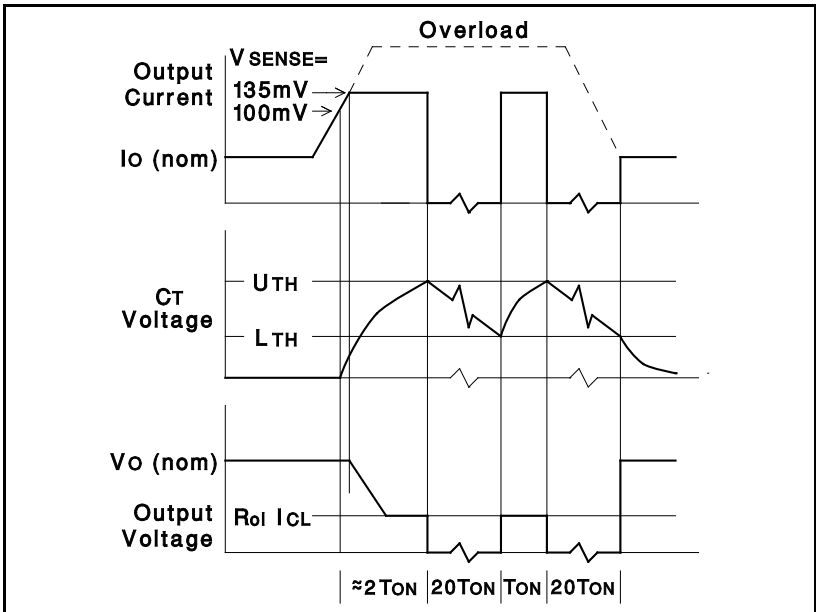

APPLICATION AND OPERATION INFORMATION (cont.)

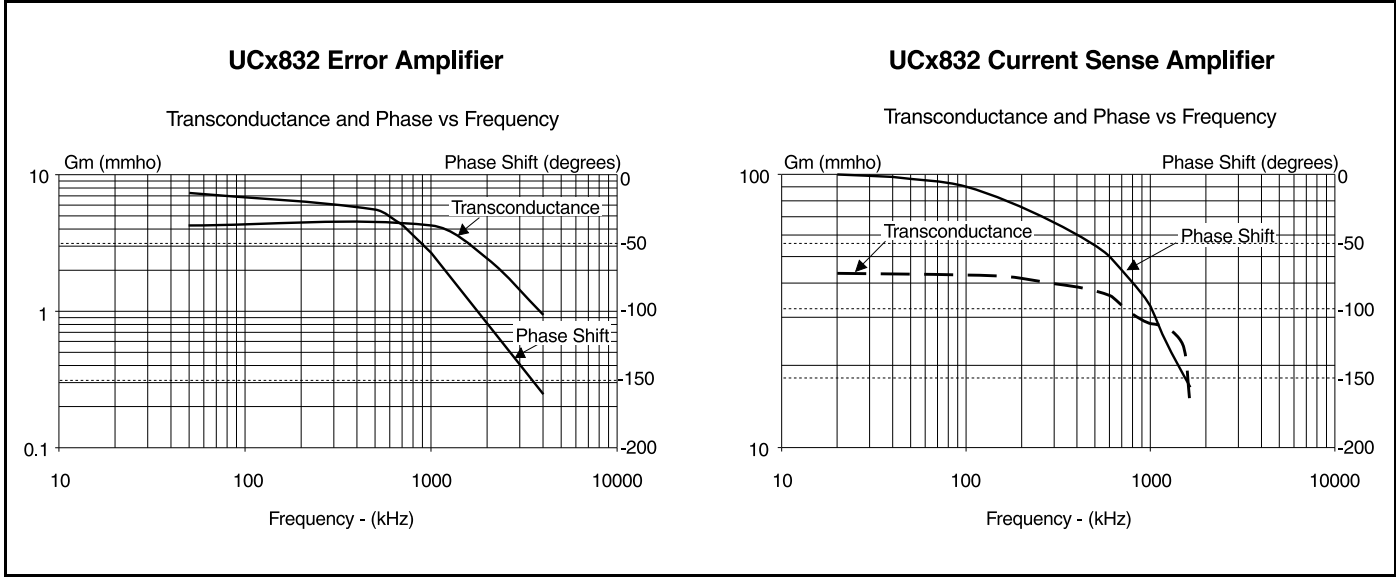
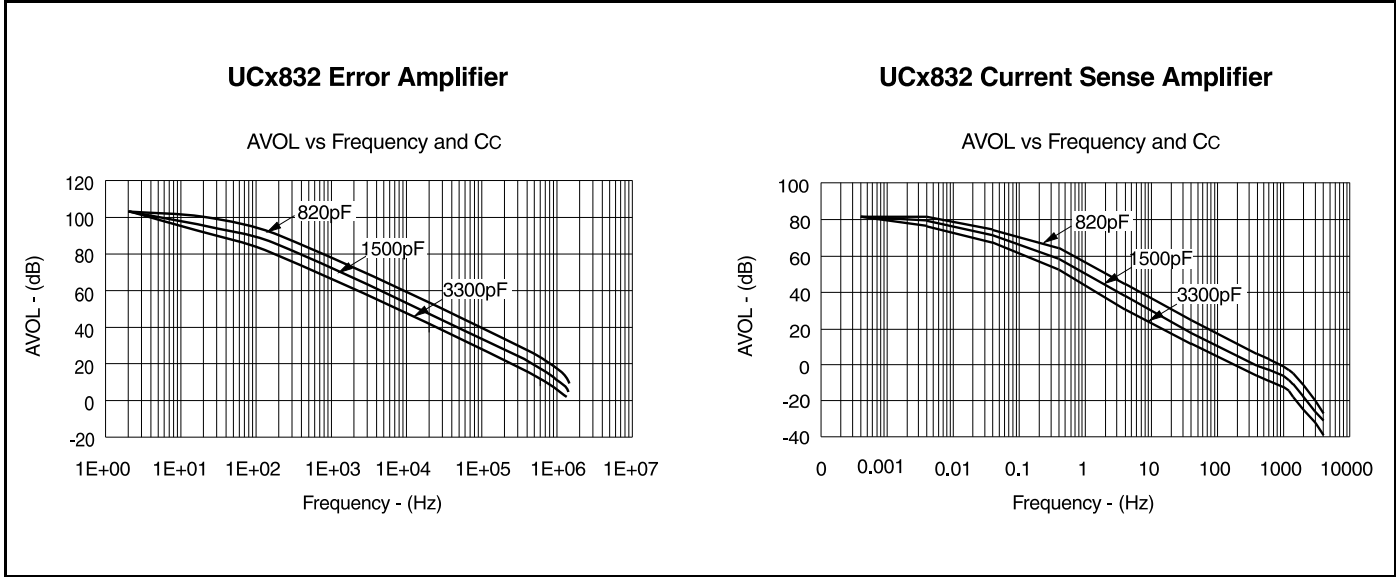

IMPORTANT NOTICE

Texas Instruments and its subsidiaries (TI) reserve the right to make changes to their products or to discontinue any product or service without notice, and advise customers to obtain the latest version of relevant information to verify, before placing orders, that information being relied on is current and complete. All products are sold subject to the terms and conditions of sale supplied at the time of order acknowledgement, including those pertaining to warranty, patent infringement, and limitation of liability.

TI warrants performance of its semiconductor products to the specifications applicable at the time of sale in accordance with TI's standard warranty. Testing and other quality control techniques are utilized to the extent TI deems necessary to support this warranty. Specific testing of all parameters of each device is not necessarily performed, except those mandated by government requirements.

CERTAIN APPLICATIONS USING SEMICONDUCTOR PRODUCTS MAY INVOLVE POTENTIAL RISKS OF DEATH, PERSONAL INJURY, OR SEVERE PROPERTY OR ENVIRONMENTAL DAMAGE ("CRITICAL APPLICATIONS"). TI SEMICONDUCTOR PRODUCTS ARE NOT DESIGNED, AUTHORIZED, OR WARRANTED TO BE SUITABLE FOR USE IN LIFE-SUPPORT DEVICES OR SYSTEMS OR OTHER CRITICAL APPLICATIONS. INCLUSION OF TI PRODUCTS IN SUCH APPLICATIONS IS UNDERSTOOD TO BE FULLY AT THE CUSTOMER'S RISK.

In order to minimize risks associated with the customer's applications, adequate design and operating safeguards must be provided by the customer to minimize inherent or procedural hazards.

TI assumes no liability for applications assistance or customer product design. TI does not warrant or represent that any license, either express or implied, is granted under any patent right, copyright, mask work right, or other intellectual property right of TI covering or relating to any combination, machine, or process in which such semiconductor products or services might be or are used. TI's publication of information regarding any third party's products or services does not constitute TI's approval, warranty or endorsement thereof.

- [Advanced Search](#)
- [TI Home](#)
- [TI&ME](#)
- [Employment](#)
- [Tech Support](#)
- [Comments](#)
- [Site Map](#)
- [TI Global](#)

Power Management

> > [Power Management](#) > [PWM Power Supply Products](#) > [Current Mode](#)



UCC3803, LOW-POWER BICMOS CURRENT-MODE PWM

Device Status: Active

- > [Description](#)
- > [Features](#)
- > [Datasheets](#)
- > [Pricing/Samples/Availability](#)
- > [Application Notes](#)
- > [Applications](#)

Parameter Name	UCC3803
Shutdown	No
Output Type	Single, Totem Pole
Output Current (mA)	+/-1000
Frequency (max) (kHz)	1000
Pulse - by - Pulse Isense	Yes
Reference Voltage (V)	4
Vref tol (%)	1.5
Startup Current (uA)	100
Duty Cycle (max) (%)	100
Operating Supply Current (mA)	0.5
Operating Supply (max) (V)	12
Operating Supply (min) (V)	3.6
PWM Outputs (#)	1
Error Amplifier GBW (mHz)	2

Description



The UCC1800/1/2/3/4/5 family of high-speed, low-power integrated circuits contain all of the control and drive components required for off-line and DC-to-DC fixed frequency current-mode switching power supplies with minimal parts count.

These devices have the same pin configuration as the UC1842/3/4/5 family, and also offer the added features of internal full-cycle soft start and internal leading-edge blanking of the current-sense input.

The UCC1800/1/2/3/4/5 family offers a variety of package options, temperature range

The UCC1800/11/21/31/41/5 family offers a variety of package options, temperature range options, choice of maximum duty cycle, and choice of critical voltage levels. Lower reference parts such as the UCC1803 and UCC1805 fit best into battery operated systems, while the higher reference and the higher UVLO hysteresis of the UCC1802 and UCC1804 make these ideal choices for use in off-line power supplies.

The UCC180x series is specified for operation from -55°C to $+125^{\circ}\text{C}$, the UCC280x series is specified for operation from -40°C to $+85^{\circ}\text{C}$, and the UCC380x series is specified for operation from 0°C to $+70^{\circ}\text{C}$.

Features

- 100uA Typical Starting Supply Current
- 500uA Typical Operating Supply Current
- Operation to 1MHz
- Internal Soft Start
- Internal Fault Soft Start
- Internal Leading-Edge Blanking of the Current Sense Signal
- 1 Amp Totem-Pole Output
- 70ns Typical Response from Current-Sense to Gate Drive Output
- 1.5% Tolerance Voltage Reference
- Same Pinout as UC3842 and UC3842A

To view the following documents, [Acrobat Reader 3.x](#) is required.

To download a document to your hard drive, right-click on the link and choose 'Save'.

Datasheets

Full datasheet in Acrobat PDF: [slus270.pdf](#) (210 KB)

Full datasheet in Zipped PostScript: [slus270.psz](#) (154 KB)

Pricing/Samples/Availability

Orderable Device	Package	Pins	Temp (°C)	Status	Price/unit USD (100-999)	Pack Qty	Availability / Samples
UCC3803D	D	8	0 TO 70	ACTIVE	1.95	1	Check stock or order
UCC3803DTR	D	8	0 TO 70	ACTIVE	1.77	1	Check stock or order
UCC3803N	P	8	0 TO 70	ACTIVE	1.91	1	Check stock or order
UCC3803PW	PW	8	0 TO 70	ACTIVE	2.14	1	Check stock or order
UCC3803PWTR	PW	8	0 TO 70	ACTIVE	1.92	1	Check stock or order

Application Reports

- [CONDITIONING A SWITCH-MODE POWER SUPPLY CURRENT SIGNAL USING TI OP AMPS \(SLOA044 - Updated: 03/26/2000\)](#)
- [DN-42A DESIGN CONSIDERATIONS FOR TRANSITIONING FROM UC3842 TO THE NEW UCC3802 \(SLUA084 - Updated: 12/02/1999\)](#)
- [DN-43 SIMPLE TECHNIQUES TO GENERATE A NEGATIVE VOLTAGE BIAS SUPPLY \(SLOA042 - Updated: 12/02/1999\)](#)

- [SOT111](#) (SLUA072 - Updated: 12/02/1999)
- [DN-46 HIGHLY EFFICIENT LOW POWER DC TO DC INVERTER CONVERTS PLUS5V INPUT TO -3V OUT](#) (SLUA179 - Updated: 11/04/1999)
 - [DN-48 VERSATILE LOW POWER SEPIC CONVERTER ACCEPTS WIDE INPUT VOLTAGE RANGE](#) (SLUA158 - Updated: 12/02/1999)
 - [DN-54 INNOVATIVE BUCK REGULATOR USES HIGH SIDE N-CHANNEL SWITCH WITHOUT COMPLEX](#) (SLUA185 - Updated: 12/02/1999)
 - [DN-56A, SINGLE SWITCH FLYBACK CIRCUIT CONVERTS PLUS 5 V TO PLUS/- 12 V FOR RS-232/422](#) (SLUA046 - Updated: 12/02/1999)
 - [DN-65 CONSIDERATIONS IN POWERING BICMOS ICS](#) (SLUA081 - Updated: 12/02/1999)
 - [ELECTROSTATIC DISCHARGE APPLICATION NOTE](#) (SSYA008 - Updated: 05/05/1999)
 - [THERMAL CHARACTERISTICS OF LINEAR AND LOGIC PACKAGES USING JEDEC PCB DESIGNS](#) (SZZA017A - Updated: 09/10/1999)
 - [U-133A UCC3800/1/2/3/4/5 BICMOS CURRENT MODE CONTROL IC'S](#) (SLUA149 - Updated: 11/04/1999)

Table Data Updated on: 8/15/2000