

THIS DRAWING IS UNPUBLISHED. RELEASED FOR PUBLICATION 20  
 © COPYRIGHT 20 BY - ALL RIGHTS RESERVED.

REVISIONS				
P	LTR	DESCRIPTION	DATE	APVD
J		MATERIAL CHANGE TO LCP	16OCT2018	KJK PS

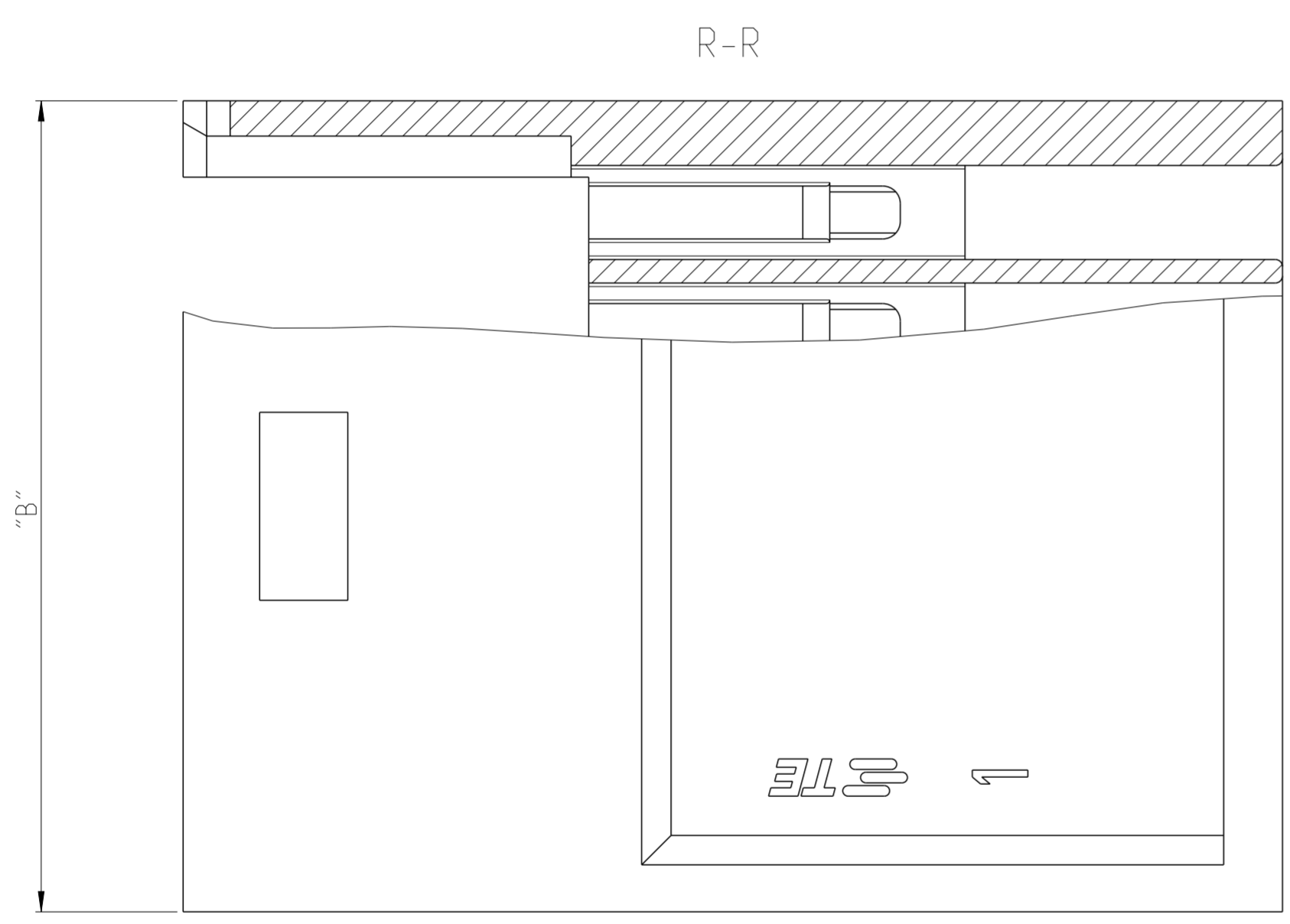
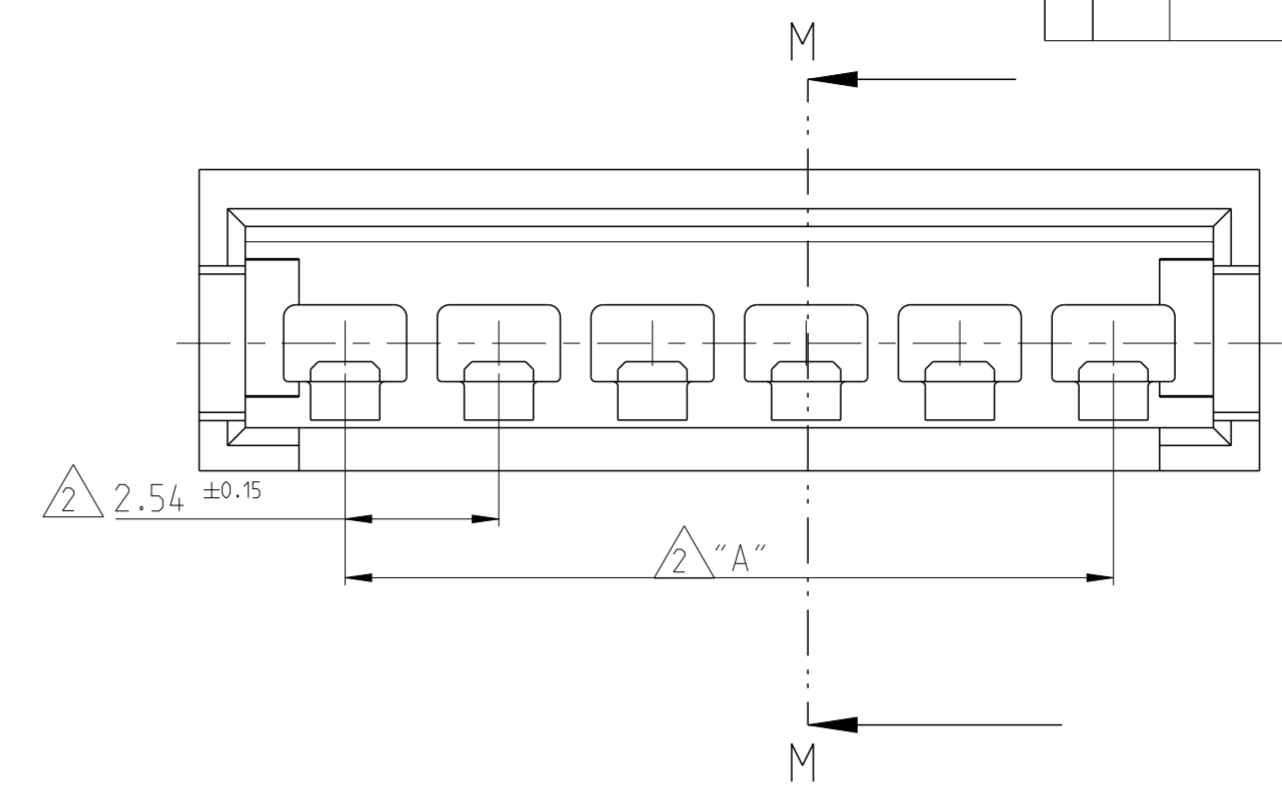
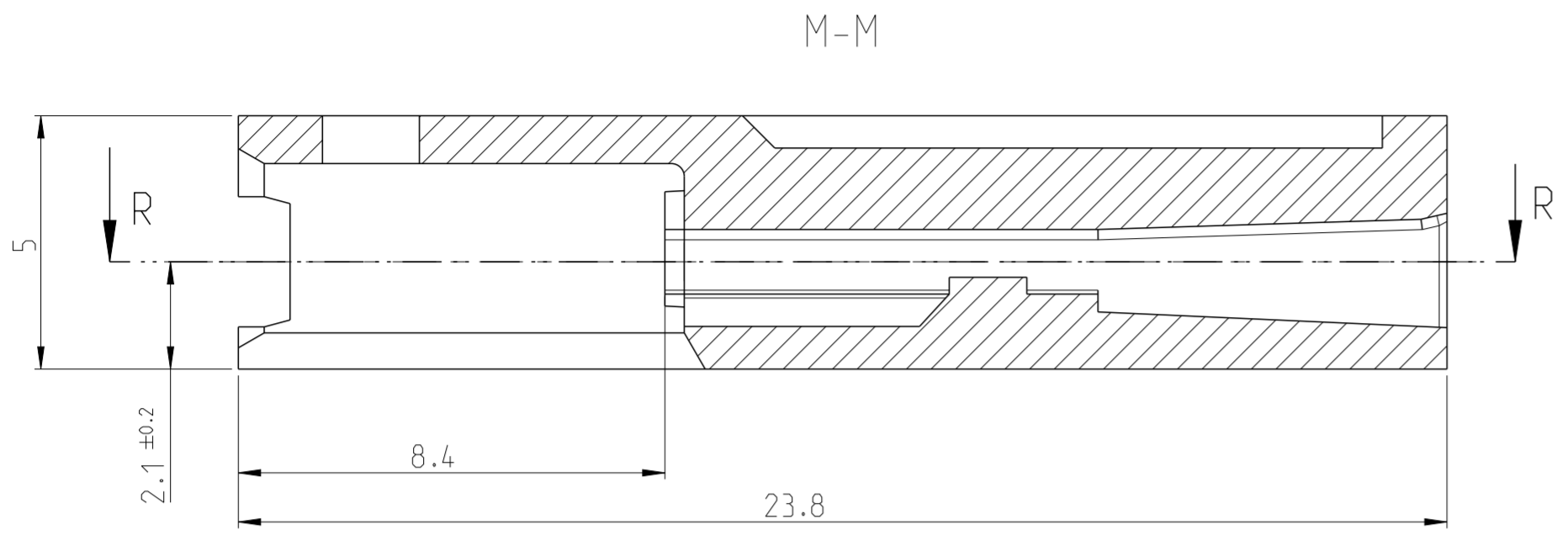

- NOTES:
- 1 LCP, BLACK, UL94V-0
  - 2 TOLERANCE NOT CUMULATIVE
  - 3 PA6.6 15% GF, RED
  - 4 OBSOLETE

NUM OF POS	PART NUMBER	DIM "A"	DIM "B"	MATERIAL
4	284072-1	7.62	12.5	3
2	284071-1	2.54	7.4	
22	280636	53.54	58.2	1
15	280635	35.56	40.4	
12	280634	27.94	32.8	
10	280633	22.86	27.7	
9	280632	20.32	25.1	
8	280631	17.78	22.6	
6	280630	12.70	17.5	
4	280629	7.62	12.5	
2	280628	2.54	7.4	

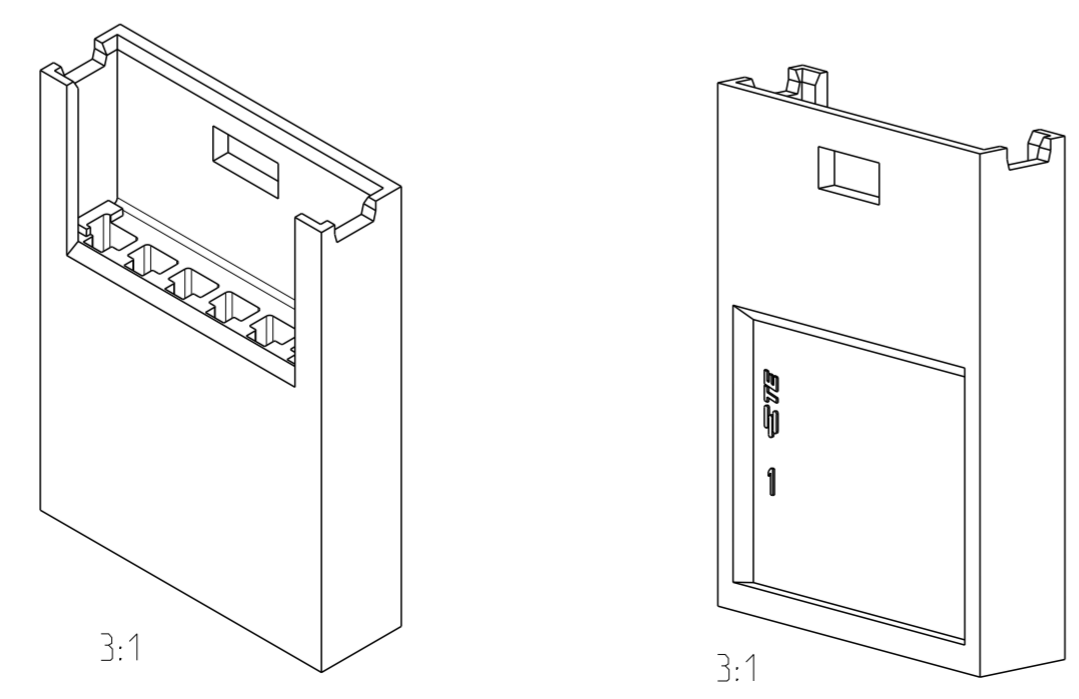

THIS DRAWING IS A CONTROLLED DOCUMENT.

DIMENSIONS: mm	TOLERANCES UNLESS OTHERWISE SPECIFIED: ±0.3	DWN KARTHIK J K 15OCT2018	TE Connectivity
	0 PLC ±	CHK SHARATH S 16OCT2018	
	1 PLC ±	APVD PRASHANTH S 16OCT2018	NAME AMPMODU II PIN HOUSING SINGLE ROW, CRIMP SNAP-IN
	2 PLC ±	PRODUCT SPEC 108-20025	SIZE A2
	3 PLC ±	APPLICATION SPEC -	CAGE CODE 00779
	4 PLC ±	WEIGHT -	DRAWING NO C-280628
	ANGLES ±2°	CUSTOMER DRAWING	RESTRICTED TO
	FINISH -	SCALE 8:1	SHEET 1 OF 1
			REV J