

THIS DRAWING CONTAINS INFORMATION PROPRIETARY TO RF INDUSTRIES.
 ANY UNAUTHORIZED USE OF THIS DRAWING IS EXPRESSLY PROHIBITED
 WITHOUT WRITTEN PERMISSION FROM RF INDUSTRIES.
 ANY VIOLATION IS PUNISHABLE UNDER U.S. COPYRIGHT LAWS.

ALL DIMENSIONS ARE REFERENCE ONLY

PART NO.

RFT-1203-1X

| REV | DESCRIPTION | DWN | DATE | APPROVED |
|-----|----------------------------|-----|----------|----------|
| A | ENGINEERING RELEASE | CZS | 11/11/97 | R. RICE |
| B | REMOVE P/N \ CHG CRIMP DIE | CZS | 6/8/99 | R. RICE |
| C | UPDATED DWG FORMAT | CZS | 5/28/99 | JDMc |

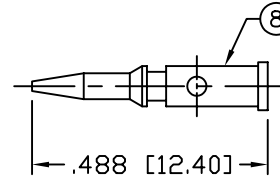
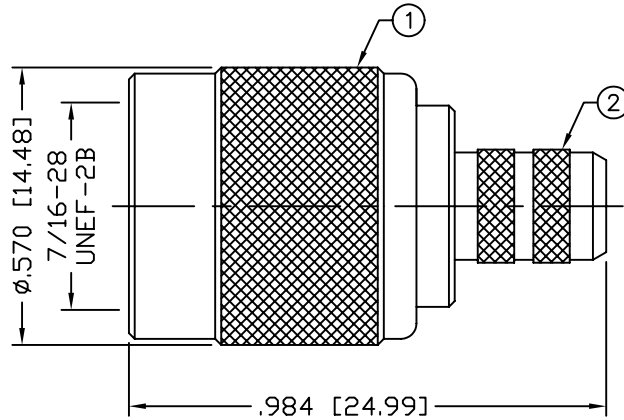

RECOMMENDED CRIMP DIE: .068

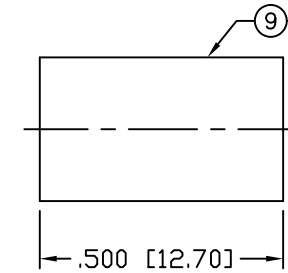

RECOMMENDED CRIMP DIE: .255

SPECIFICATIONS:

IMPEDANCE: 50 Ohms
 FREQUENCY RANGE: 0-7 GHz
 WORKING VOLTAGE: 500 V rms @ sea level
 INSULATION RESISTANCE: 5k M ohms min.
 TEMPERATURE RANGE: -65°C TO +165°C
 FOR RG-8/X, BELDEN 9258, MAXRAD M8X-100 &
 M8X-1000, MICRO 8/U, REMEE 1600, SAXTON 8315 &
 TIMES LMR-240 & LMR-240 ULTRAFLEX CABLE

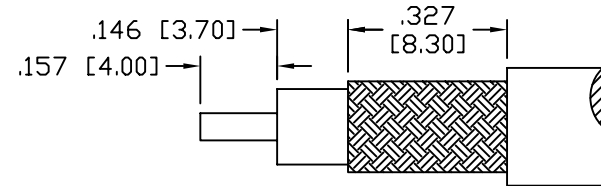

RECOMMENDED STRIPPING DIMENSIONS

| 1 | SHELL | 1 | BRASS | NICKEL, 100μ ² | 008974 | |
|----|----------------|-----|----------|---------------------------|-----------|----------|
| 2 | BODY | 1 | BRASS | NICKEL, 100μ ² | | |
| 3 | INSULATOR | 1 | DELTRIN | ---- | | |
| 4 | GASKET | 1 | RUBBER | ---- | | |
| 5 | RETAINING RING | 1 | BRASS | NICKEL, 100μ ² | | |
| 6 | RING | 1 | DELTRIN | ---- | | |
| 7 | WASHER | 1 | BRASS | NICKEL, 100μ ² | | |
| 8 | PIN | 1 | BRASS | GOLD, 3μ ² | | |
| 9 | FERRULE | 1 | BRASS | NICKEL, 100μ ² | | |
| 10 | | | | | DRAWN | |
| 11 | | | | | C. ZUNIGA | 4/12/06 |
| 12 | | | | | CHECKED | |
| 13 | | | | | ORJ DRAWN | |
| 14 | | | | | C. ZUNIGA | 11/11/97 |
| # | DESCRIPTION | QTY | MATERIAL | FINISH | APPROVALS | DATE |

UNLESS OTHERWISE SPECIFIED:

DIMENSIONS ARE IN INCHES AND [MILLIMETERS]
 UNLESS OTHERWISE NOTED TOLERANCES ARE:

| | |
|----------|----------|
| DECIMALS | DIAMETER |
|----------|----------|

RF connectors
 DIVISION OF RF INDUSTRIES, LTD.

7610 MIRAMAR RD
 SAN DIEGO, CA 92126
 (858) 549-6340
 (858) 549-6345 FAX

TNC PLUG, CRIMP

| | | | |
|------|-------------|-------------|-----|
| SIZE | CABLE GROUP | DWG NO. | REV |
| A | X | RFT-1203-1X | C |

SCALE: NTS CAD FILE OUTLINE SHEET 1 OF 1