

PART NUMBER	REV	FIRST USED
567174-2	B	565435-5
567174-3	-	SEE DWG 567174-3
567174-4	B	354500-1

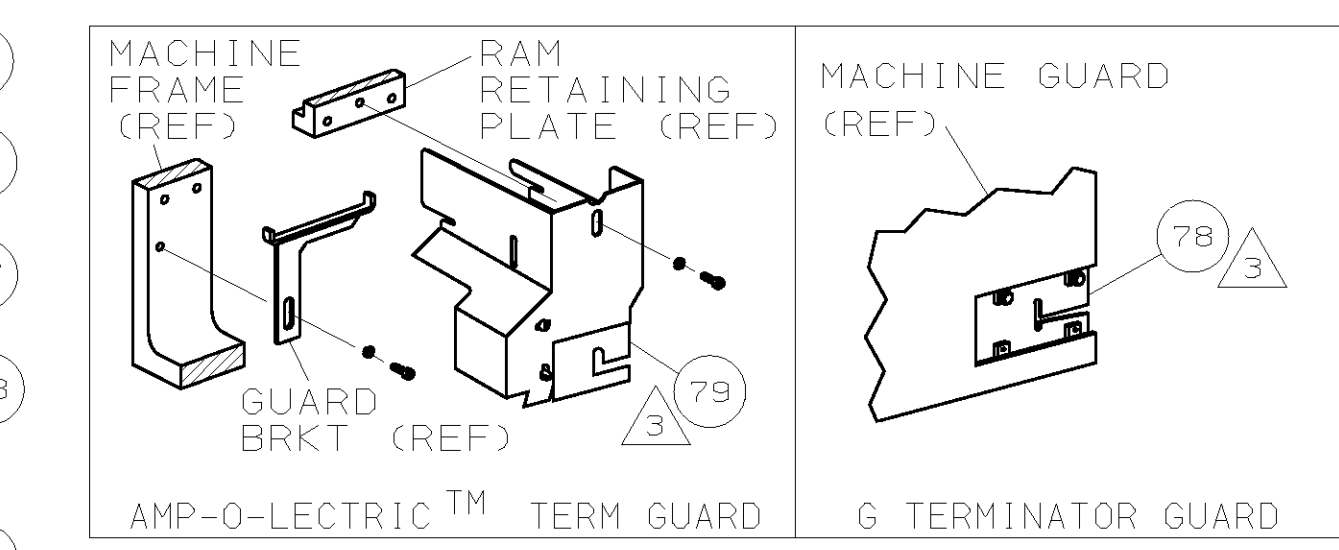
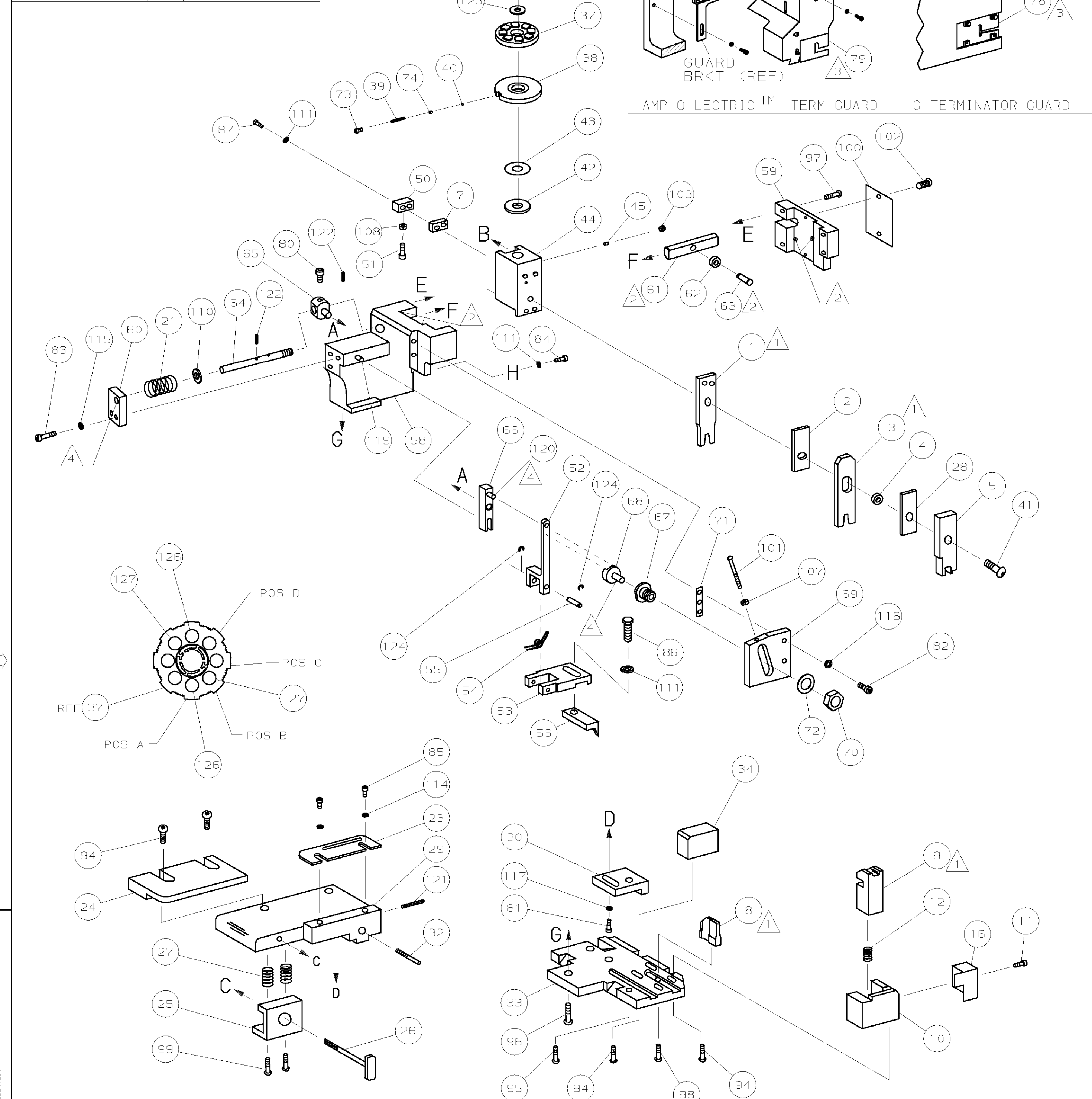

TERMINAL NAME: TYPE III + Ø.062 PIN & SOCKET		CRIMPING DATA			
PIN	SOCKET	PAD LTR	CRIMP HEIGHT	WIRE SIZE	
66761	66762	A	.084 ±.002 [2.13 ±0.05mm]	(1)16 + (1)18	
		B	.074 ±.002 [1.88 ±0.05mm]	14	
		C	NOT	USED	
		D	NOT	USED	
CRIMP	SIZE	TYPE	RANGE		
WIRE	.100 [2.54mm]	F	18-14		
INSUL	.155 [3.94mm]	0	.110-.150		
WIRE STRIP LENGTH	TERM APPL SPEC	FEED	APPL INSTRUCTION	SET UP GAGE	LAYOUT
-	114-10004	.500		458637-1	1018

-2		BENCH MODEL K		MECH PRE FEED		
-4		BENCH MODEL G		MECH PRE FEED		
REF	REF	-	B	22594-8	NUT, HEX (1/2-20)	70
REF	REF	-	B	240628-1	PLATE, ADJUSTMENT	69
REF	REF	-	B	240626-1	SHAFT, PIVOT	68
REF	REF	-	B	240633-1	BUSHING	67
REF	REF	-	A	455680-1	LEVER, INTERMEDIATE	66
REF	REF	-	B	240629-1	BLOCK, PIVOT	65
REF	REF	-	A	240632-2	SCREW, ADJ FEED ROD	64
REF	REF	-	B	240659-3	PIN, CAM ROLLER	63
REF	REF	-	B	240658-1	ROLLER, CAM	62
REF	REF	-	B	454398-2	ROD, FEED	61
REF	REF	-	A	454178-1	GUIDE, FEED ROD	60
REF	REF	-	C	454220-1	CAP, RAM	59
REF	REF	-	D	454485-1	HOUSING	58
						57
1	1	-	B	690542-2	PAWL, FEED	56
REF	REF	-	B	240624-1	PIN, FEED FINGER	55
REF	REF	-	B	691499-1	SPRING, FEED FINGER	54
REF	REF	-	B	690541-1	HOLDER, FEED FINGER	53
REF	REF	-	A	455679-1	LEVER, TERMINAL FEED ARM	52
1	1	-	A	811242-2	BUMPER, HOLDDOWN	51
1	1	-	A	690753-1	SPACER, TONKER	50
1	-	-	B	690602-6	CAM, PRE-FEED 1 5/8 ST	49
-	1	-	B	690602-5	CAM, PRE-FEED 1 1/8 ST	48
						47
1	1	-	B	459456-1	APPLICATOR, BASIC (SUBASSY)	46
1	1	-	A	690191-1	PLUG, NYLON	45
1	1	-	C	455673-1	RAM	44
1	1	-	A	690125-1	WASHER, LAMINATED	43
1	1	-	A	690124-1	WASHER, RAM	42
1	1	-	A	7-21002-9	BOLT, CRIMPER (5/16x1.00)	41
1	1	-	A	23241-6	BALL, STEEL	40
1	1	-	A	690170-1	SPRING, COMPRESSION	39
1	1	-	C	690142-1	DISC, INSULATION	38
1	1	-	D	354777-1	WIRE DISC, PLASTIC	37
1	1	-	A	22480-5	WASHER, SPRING	36
1	1	-	B	690212-1	POST, RAM	35
1	1	-	B	690786-6	SUPPORT, TERMINAL	34
REF	REF	-	D	455675-1	PLATE, BASE	33
1	1	-	A	690432-3	SCREW, ADJUSTMENT	32
						31
REF	REF	-	B	455689-1	BLOCK, STRIP GUIDE ADJ	30
1	1	-	C	455671-9	PLATE, STRIP GUIDE	29
1	1	-	C	1-455888-0	SPACER, FRONT SHEAR DEP	28
2	2	-	A	1-22284-0	SPRING, DRAG	27
1	1	-	B	690546-1	LEVER, DRAG RELEASE	26
1	1	-	B	240792-1	DRAG, TERMINAL	25
1	1	-	D	6-690504-1	GUIDE, STRIP (REAR)	24
1	1	-	A	690438-1	GUIDE, STRIP (FRONT)	23
						22
REF	REF	-	A	4-22284-9	SPRING, FEED RETURN	21
1	1	-	A	679218-1	STRIPPER WIRE STOP ASSY	20
1	1	-	B	458949-1	STRIPPER	19
						18
						17
1	1	-	B	691667-1	GUARD, CHIP (FRONT)	16
						15
						14
						13
1	1	-	A	5-22280-0	SPRING, SHEAR	12
1	1	-	B	690461-1	STOP, SHEAR	11
1	1	-	C	690459-1	HOLDER, SHEAR (FRONT)	10
1	1	-	C	462006-1	SHEAR, FLOAT (FRONT)	9
1	1	-	C	803653-9	ANVIL	8
1	1	-	C	3-240641-7	SPACER, DEPRESSOR (REAR)	7
						6
1	1	-	C	2-455889-0	DEPRESSOR, SHEAR (FRONT)	5
1	1	-	B	238011-4	SPACER, BLOCK CRIMPER	4
1	1	-	C	7-456135-2	CRIMPER, INSULATION	3
1	1	-	C	455888-1	SPACER, CRIMPER	2
1	1	-	C	456407-3	CRIMPER, WIRE	1

- 1 RECOMMENDED SPARE PARTS.
- 2 GREASE LIGHTLY.
- 3 GUARD MUST BE IN PLACE WHEN OPERATING APPLICATOR IN A BENCH MACHINE.
- 4 LUBRICATE DAILY USING NO. 20 MACHINE OIL.
- 5. ITEMS WITH QTY OF REF SPECIFIED (EXCEPT ITEMS 78 AND 79) ARE USED ON ITEM 46.
- 6 CUT TO LENGTH AT ASSEMBLY.

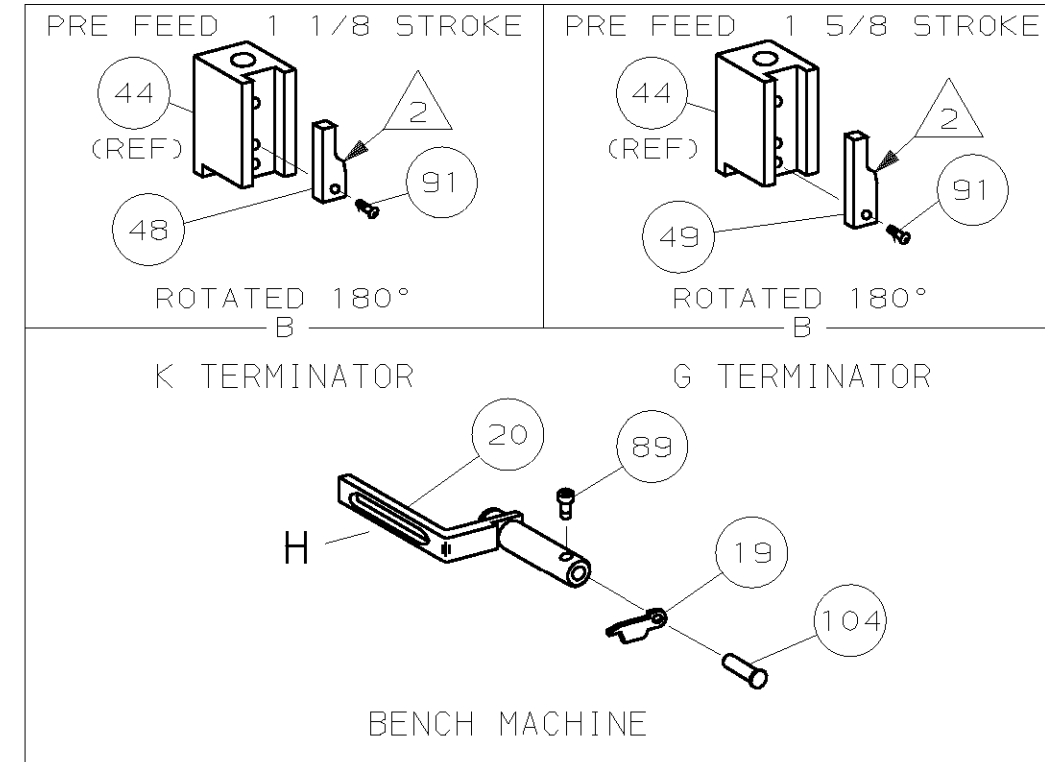

QTY	REF	REV	U/M	DWG SIZE	PART NO	DESCRIPTION	ITEM NO
2	2	-	C		7-354778-3	PIN, WIRE DISC (.2860)B	129
2	2	-	C		5-354778-3	PIN, WIRE DISC (.2760)A	127
1	1	-	A		986950-1	WASHER, FLAT PRECISION	125
REF	REF	-	A		21045-3	RING, RET "C" (Ø.187) FD FING PIN	124
							123
REF	REF	-	A		5-21028-1	PIN, SLT SPR (Ø.125x.50) ADJ ROD	122
1	1	-	A		4-21028-0	PIN, SLT SPR (Ø.093x.75) ST GDE PL	121
REF	REF	-	A		1-21030-1	PIN, DOWEL (Ø.187x.50) LEVER	120
REF	REF	-	A		1-21030-6	PIN, DOWEL (Ø.187x1.25) HOUSING	119
							118
1	1	-	A		21024-5	WASHER, LOCK (#10) ADJ BLOCK	117
REF	REF	-	A		21024-5	WASHER, LOCK (#10) ADJ PLATE	116
REF	REF	-	A		21024-5	WASHER, LOCK (#10) FEED GDE ROD	115
2	2	-	A		21024-2	WASHER, LOCK (#4) FRONT STP GUIDE	114
							113
							112
4	4	-	A		21024-4	WASHER, LOCK (#8) STRIPPER	111
REF	REF	-	A		21899-4	WASHER, FLAT (Ø5/16) SCREW ADJ	110
							109
1	1	-	A		21018-5	NUT, HEX (NO. 6) HOLDDOWN	108
REF	REF	-	A		21018-5	NUT, HEX (6-32) FEED ADJ	107
							106
							105
1	1	-	A		992031-1	PIN, CLEVIS	104
1	1	-	A		21009-2	SCR, SKT SET (1/4-20x.25 LW) RAM	103
2	2	-	A		21017-2	SCR, DRIVE (#2x.19) ID PLATE	102
REF	REF	-	A		6-23715-5	SCR, PAN HD (6-32x1.50) FEED ADJ	101
1	1	-	B		461264-1	PLATE, IDENTIFICATION	100
2	2	-	A		3-21002-0	SCR, BHC (10-32x.88) DRAG	99
1	1	-	A		22733-8	SCR, BHC (8-32x.38 LW) ANVIL	98
REF	REF	-	A		2-21002-9	SCR, BHC (10-32x.75) CAP	97
REF	REF	-	A		2-22733-8	SCR, BHC (1/4-20x.62) HOUSING	96
REF	REF	-	A		2-21002-7	SCR, BHC (10-32x.50) 5G ADJ BLOCK	95
6	6	-	A		2-21002-2	SCR, BHC (8-32x.50) TERM H DWN	94
							93
							92
1	1	-	A		1-21002-7	SCR, BHC (6-32x.38) CAM	91
							90
1	1	-	A		7-21000-9	SCR, SHC (4-40x.19) STRIPPER	89
							88
2	2	-	A		2-21000-8	SCR, SHC (8-32x.57) DEP-HOLD	87
1	1	-	A		2-22603-0	SCR, HEX HD (8-32x.31) FEED FINGER	86
2	2	-	A		1-21000-3	SCR, SHC (4-40x.25) F ST GUIDE	85
1	1	-	A		2-21000-7	SCR, SHC (8-32x.50) STRIPPER	84
REF	REF	-	A		3-21000-7	SCR, SHC (10-32x.75) FEED ROD 6D	83
REF	REF	-	A		3-21000-6	SCR, SHC (10-32x.62) FD ADJ BLK	82
1	1	-	A		3-21000-4	SCR, SHC (10-32x.38) 5G ADJ BL	81
REF	REF	-	A		3-21000-4	SCR, SHC (10-32x.38) PIVOT BLK	80
-	REF	-	B		455749-1	GUARD, WINDOW	79
REF	-	-	B		679532-1	INSERT, GUARD	78
							77
							76
							75
1	1	-	A		690603-1	SPRING, ASSIST	74
1	1	-	A		23030-1	SCR, SHC (6-32x.25 SL) INS DISC	73
REF	REF	-	A		458109-1	WASHER, SPECIAL	72
REF	REF	-	A		690517-1	SPACER	71
							70
							69
							68
							67
							66
							65
							64
							63
							62
							61
							60
							59
							58
							57
							56
							55
							54
							53
							52
							51
							50
							49
							48
							47
							46
							45
							44
							43
							42
							41
							40
							39
							38
							37
							36
							35
							34
REF	REF	-	D		455675-1	PLATE, BASE	33
1	1	-	A		690432-3	SCREW, ADJUSTMENT	32
							31
REF	REF	-	B		455689-1	BLOCK, STRIP GUIDE ADJ	30
1	1	-	C		455671-9	PLATE, STRIP GUIDE	29
1	1	-	C		1-455888-0	SPACER, FRONT SHEAR DEP	28
2	2	-	A		1-22284-0	SPRING, DRAG	27
1	1	-	B		690546-1	LEVER, DRAG RELEASE	26
1	1	-	B		240792-1	DRAG, TERMINAL	25
1	1	-	D		6-690504-1	GUIDE, STRIP (REAR)	24
1	1	-	A		690438-1	GUIDE, STRIP (FRONT)	23
							22
REF	REF	-	A		4-22284-9	SPRING, FEED RETURN	21
1	1	-	A		679218-1	STRIPPER WIRE STOP ASSY	20
1	1	-	B		458949-1	STRIPPER	19
							18
							17
1	1	-	B		691667-1	GUARD, CHIP (FRONT)	16
							15
							14
							13
1	1	-	A		5-22280-0	SPRING, SHEAR	12
1	1	-	B		690461-1	STOP, SHEAR	11
1	1	-	C		690459-1	HOLDER, SHEAR (FRONT)	10
1	1	-	C		462006-1	SHEAR, FLOAT (FRONT)	9
1	1	-	C		803653-9	ANVIL	8
1	1	-	C		3-240641-7	SPACER, DEPRESSOR (REAR)	7
							6
1	1	-	C		2-455889-0	DEPRESSOR, SHEAR (FRONT)	5
1							