

REVISIONS				
P	LTR	DESCRIPTION	DATE	APP'D
S2	REVISED PER ECO-17-018523		19JAN2018	PHM CT

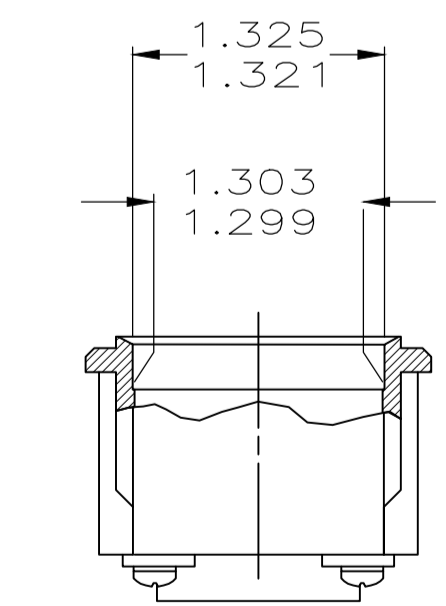
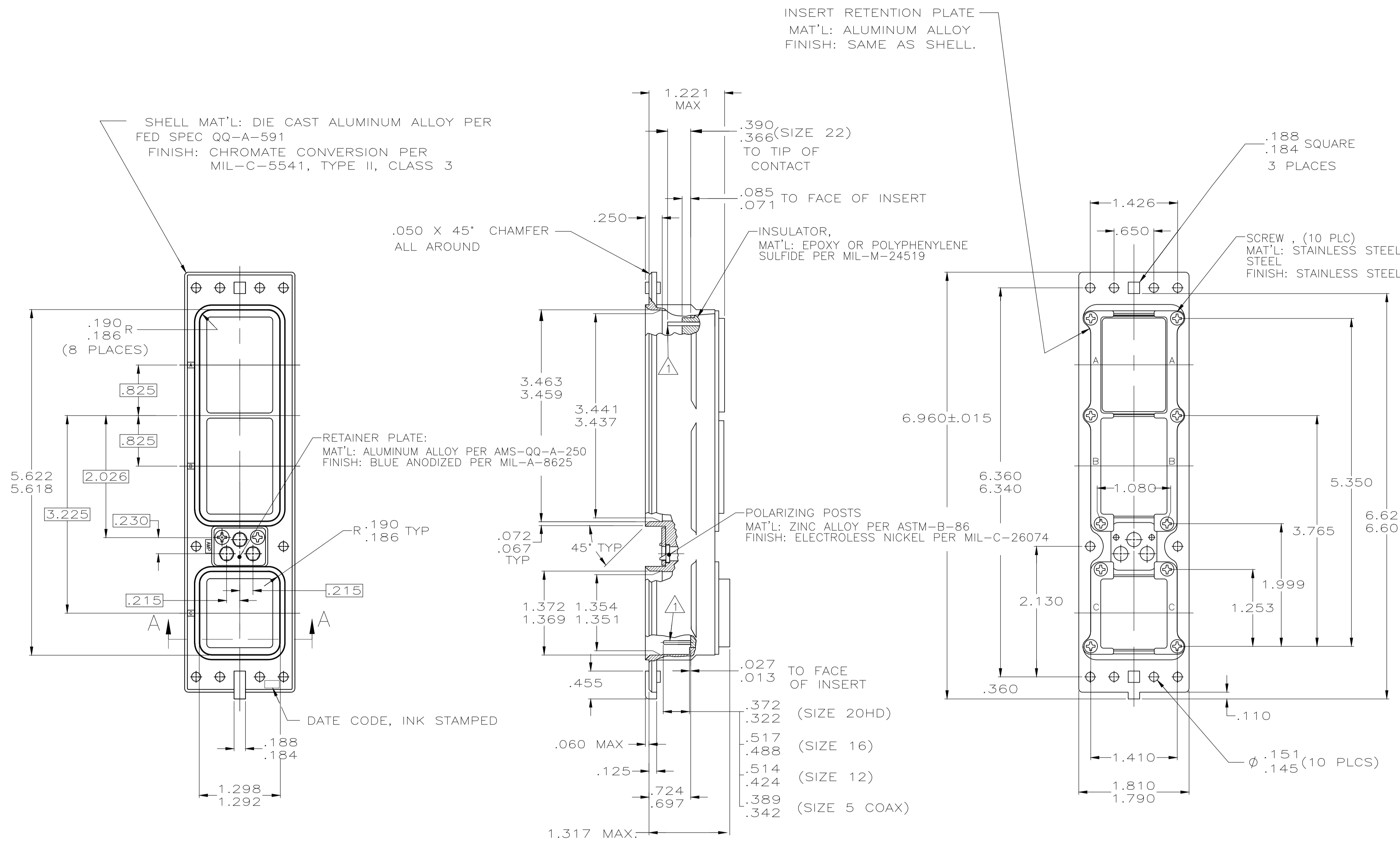

SECTION A-A
PARTIAL

- CONTACTS ARE SHOWN IN POSITION FOR ILLUSTRATION ONLY. FOR SHIPMENT, CONTACTS ARE INCLUDED IN A CONTAINER WITHIN THE CONNECTOR PACKAGE.
 - ALL CONTACT CAVITIES IN MODULES "A" & "B" ARE LOCATED WITHIN .006 DIA. TRUE POSITION. ALL CONTACT CAVITIES IN MODULE "C" ARE LOCATED WITHIN .020 DIA TRUE POSITION.
 - COAX CONTACTS NOT SUPPLIED IN KITS. MUST BE ORDERED SEPARATELY.
 - POLARIZING KEYS SHOWN IN POSITION "01" FOR ILLUSTRATION ONLY- CONNECTORS SHIPPED WITH KEYING PER ORDERING INSTRUCTIONS. CONTACT INSERTS AS SHOWN FOR ILLUSTRATION ONLY- SEE TABLE FOR DESCRIPTIVE NUMBER.
- INSERT MATERIAL: DIE CAST ALUMINUM PER ASTM-B-85

REMARKS	DESCRIPTIVE NUMBER	PART NUMBER
PRELIMINARY NOT RELEASED FOR PRODUCTION	NIC66G23A05SF1	2-208970-8
PRELIMINARY NOT RELEASED FOR PRODUCTION	NIC66G23A05AA1	2-208970-7
-	NIC66G21A03AA0	2-208970-6
(G21A29CC1) W/DUST CAP	SPECIAL	2-208970-5
-	NIC66G21A05CC0	2-208970-4
-	NIC66G21A01CC0	2-208970-3
-	NIC66G21A02CC0	2-208970-2
C4/150/13C2 WITH CONTACTS & COAX	SPECIAL	2-208970-1
-	ADVANCED PART NUMBER	2-208970-0
-	SPECIAL	1-208970-9
-	NIC66G21A01SC1	1-208970-8
-	NIC66G21A19AA0	1-208970-7
-	NIC66G26A01AA0	1-208970-6
-	NIC66G51A01AA0	1-208970-5
-	NIC66G21A00AA0	1-208970-4
-	NIC66G21A02AA0	1-208970-3
-	NIC66G21A02AA1	1-208970-2
-	NIC66G21A01CA0	1-208970-1
-	NIC66G21A09CC0	1-208970-0
-	-	208970-9
BLANK/150/13C2 WITH CONTACTS	NIC66G51A01AA0	208970-8
-	ADVANCED PART NUMBER	208970-7
-	NIC66G21A01CC1	208970-6
-	NIC66G21A01BA1	208970-5
-	NIC66G21A01AA1	208970-4
-	NIC66G21A01SB1	208970-3
-	NIC66G21A01AC0	208970-2
-	NIC66G21A01AA0	208970-1

THIS DRAWING IS A CONTROLLED DOCUMENT.

DIMENSIONS: INCHES
 TOLERANCES UNLESS OTHERWISE SPECIFIED:
 0 PLC ± -
 1 PLC ± -
 2 PLC ± -
 3 PLC ± .005
 4 PLC ± -
 ANGLES ± -

MATERIAL: SEE CALLOUTS
 FINISH: SEE CALLOUTS

WEIGHT: -
 SCALE: 1:1
 SHEET: 1 OF 1
 REV: S2

THIS DRAWING IS A CONTROLLED DOCUMENT. C.C. THOMAS 4-23-01
 CHK: S. GLATFELTER 4-23-01
 APP'D: S. GLATFELTER 4-23-01
 PRODUCT SPEC: -
 APPLICATION SPEC: -
 SIZE: A1
 CAGE CODE: 00779
 DRAWING NO: 208970
 CUSTOMER DRAWING

STE TE Connectivity Ltd.
 NAME: RECEPTACLE ASSY, SIZE 2, CLASS A, ARINC 600
 RESTRICTED TO: -