

## 28-BIT TO 56-BIT REGISTERED BUFFER WITH ADDRESS-PARITY TEST

### FEATURES

- Member of the Texas Instruments Widebus+™ Family
- Pinout Optimizes DDR2 RDIMM PCB Layout
- 1-to-2 Outputs Supports Stacked DDR2 RDIMMs
- Chip-Select Inputs Gate the Data Outputs from Changing State and Minimizes System Power Consumption
- Output Edge-Control Circuitry Minimizes Switching Noise in an Unterminated Line
- Supports SSTL\_18 Data Inputs
- Differential Clock (CK and  $\overline{CK}$ ) Inputs
- Supports LVCMOS Switching Levels on the Chip-Select Gate-Enable and  $\overline{RESET}$  Inputs
- Checks Parity on DIMM-Independent Data Inputs
- Industrial Temperature range for  $T_A$  -40°C to 85°C supported
- $\overline{RESET}$  Input Disables Differential Input Receivers, Resets All Registers, and Forces All Outputs Low, Except PTYERR

### DESCRIPTION

This 28-bit 1:2 configurable registered buffer is designed for 1.7-V to 1.9-V  $V_{CC}$  operation. One device per DIMM is required to drive up to 18 SDRAM loads or two devices per DIMM are required to drive up to 36 SDRAM loads.

All inputs are SSTL\_18, except the chip-select gate-enable (CSGateEN) and reset ( $\overline{RESET}$ ) inputs, which are LVCMOS. All outputs are edge-controlled circuits optimized for unterminated DIMM loads, and meet SSTL\_18 specifications, except the open-drain error (PTYERR) output.

The 74SSTUB32865 operates from a differential clock (CK and  $\overline{CK}$ ). Data are registered at the crossing of CK going high and  $\overline{CK}$  going low.

The 74SSTUB32865 accepts a parity bit from the memory controller on the parity bit (PARIN) input, compares it with the data received on the DIMM-independent D-inputs (D0-D21) and indicates whether a parity error has occurred on the open-drain PTYERR pin (active low). The convention is even parity, i.e., valid parity is defined as an even number of ones across the DIMM-independent data inputs combined with the parity input bit. To calculate parity, all DIMM-independent D-inputs must be tied to a known logic state.

### ORDERING INFORMATION

$T_A$	PACKAGE <sup>(1)</sup>		ORDERABLE PART NUMBER	TOP-SIDE MARKING
-40°C to 85°C	TFBGA-ZJB	Tape and reel	74SSTUB32865ZJBR	SB865

- (1) Package drawings, standard packing quantities, thermal data, symbolization, and PCB design guidelines are available at [www.ti.com/sc/package](http://www.ti.com/sc/package).



Please be aware that an important notice concerning availability, standard warranty, and use in critical applications of Texas Instruments semiconductor products and disclaimers thereto appears at the end of this data sheet.

Widebus+ is a trademark of Texas Instruments.

## DESCRIPTION (CONTINUED)

If an error occurs and the  $\overline{\text{PTYERR}}$  output is driven low, it stays latched low for a minimum of two clock cycles or until  $\overline{\text{RESET}}$  is driven low. If two or more consecutive parity errors occur, the  $\overline{\text{PTYERR}}$  output is driven low and latched low for a clock duration equal to the parity error duration or until  $\overline{\text{RESET}}$  is driven low. If a parity error occurs on the clock cycle before the device enters the low-power mode (LPM) and the  $\overline{\text{PTYERR}}$  output is driven low, it stays latched low for the LPM duration plus two clock cycles or until  $\overline{\text{RESET}}$  is driven low. The DIMM-dependent signals ( $\overline{\text{DCKE0}}$ ,  $\overline{\text{DCKE1}}$ ,  $\overline{\text{DODT0}}$ ,  $\overline{\text{DODT1}}$ ,  $\overline{\text{DCS0}}$  and  $\overline{\text{DCS1}}$ ) are not included in the parity check computation.

In a typical DDR2 RDIMM application,  $\overline{\text{RESET}}$  is completely asynchronous with respect to CK and  $\overline{\text{CK}}$ . Therefore, no timing relationship can be ensured between the two. When entering reset, the register is cleared and the data outputs are quickly driven low, relative to the time to disable the differential input receivers. However, when coming out of reset, the register quickly becomes active, relative to the time to enable the differential input receivers. As long as the data inputs are low, and the clock is stable during the time from the low-to-high transition of  $\overline{\text{RESET}}$  until the input receivers are fully enabled, the 74SSTUB32865 outputs remain low, thus preventing glitches on the output.

To ensure defined outputs from the register before a stable clock has been supplied,  $\overline{\text{RESET}}$  must be held in the low state during power up.

The device supports low-power standby operation. When  $\overline{\text{RESET}}$  is low, the differential input receivers are disabled, and undriven (floating) data, clock, and reference voltage ( $V_{\text{REF}}$ ) inputs are allowed. In addition, when  $\overline{\text{RESET}}$  is low, all registers are reset and all outputs are forced low except  $\overline{\text{PTYERR}}$ . The LVCMOS  $\overline{\text{RESET}}$  input must always be held at a valid logic high or low level.

The device also supports low-power active operation by monitoring both system chip select ( $\overline{\text{DCS0}}$  and  $\overline{\text{DCS1}}$ ) and  $\text{CSGateEN}$  inputs. It gates the  $Q_n$  outputs from changing states when the  $\text{CSGateEN}$ ,  $\overline{\text{DCS0}}$ , and  $\overline{\text{DCS1}}$  inputs are high. If the  $\text{CSGateEN}$ ,  $\overline{\text{DCS0}}$  or  $\overline{\text{DCS1}}$  input is low, the  $Q_n$  outputs function normally. Also, if both  $\overline{\text{DCS0}}$  and  $\overline{\text{DCS1}}$  inputs are high, the device gates the  $\overline{\text{PTYERR}}$  output from changing states. If either  $\overline{\text{DCS0}}$  or  $\overline{\text{DCS1}}$  is low, the  $\overline{\text{PTYERR}}$  output functions normally. The  $\overline{\text{RESET}}$  input has priority over the  $\overline{\text{DCS0}}$  and  $\overline{\text{DCS1}}$  control, and when driven low forces the  $Q_n$  outputs low, and the  $\overline{\text{PTYERR}}$  output high. If the chip-select control functionality is not desired, then the  $\text{CSGateEN}$  input can be hardwired to ground, in which case, the setup-time requirement for  $\overline{\text{DCS0}}$  and  $\overline{\text{DCS1}}$  would be the same as for the other D data inputs. To control the low-power mode with  $\overline{\text{DCS0}}$  and  $\overline{\text{DCS1}}$  only, then the  $\text{CSGateEN}$  input should be pulled up to  $V_{\text{CC}}$  through a pullup resistor.

The two  $V_{\text{REF}}$  pins (A1 and V1) are connected together internally by a resistance of approximately 150  $\Omega$ . However, it is necessary to connect only one of the two  $V_{\text{REF}}$  pins to the external  $V_{\text{REF}}$  power supply. An unused  $V_{\text{REF}}$  pin should be terminated with a  $V_{\text{REF}}$  coupling capacitor.

## PINOUT

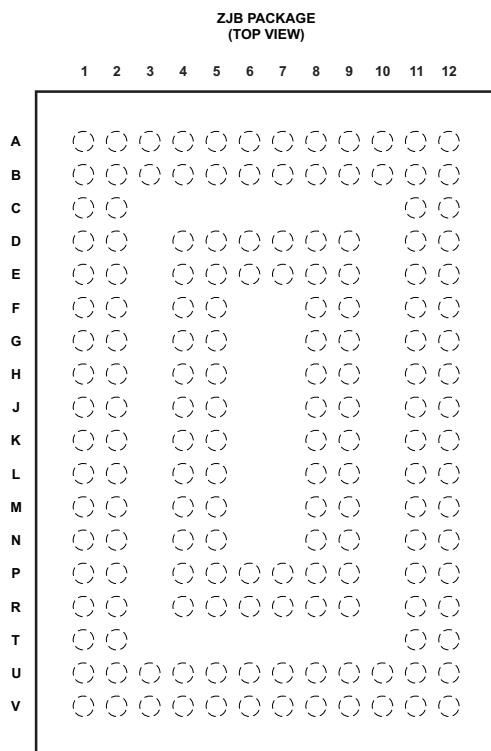

## TERMINAL ASSIGNMENTS

	1	2	3	4	5	6	7	8	9	10	11	12
<b>A</b>	VREF	NC <sup>(1)</sup>	PARIN	NC	NC	QCKE1A	QCKE0A	Q21A	Q19A	Q18A	Q17B	Q17A
<b>B</b>	D1	D2	NC	NC	NC	QCKE1B	QCKE0B	Q21B	Q19B	Q18B	QODT0B	QODT0A
<b>C</b>	D3	D4									QODT1B	QODT1A
<b>D</b>	D6	D5		VCC	GND	NC	NC	GND	GND		Q20B	Q20A
<b>E</b>	D7	D8		VCC	GND	VCC	VCC	GND	GND		Q16B	Q16A
<b>F</b>	D11	D9		VCC	GND			VCC	VCC		Q1B	Q1A
<b>G</b>	D18	D12		VCC	GND			VCC	VCC		Q2B	Q2A
<b>H</b>	CSGateE N	D15		VCC	GND			GND	GND		Q5B	Q5A
<b>J</b>	CK	$\overline{DCS0}$		GND	GND			VCC	VCC		$\overline{QCS0B}$	QCS0A
<b>K</b>	$\overline{CK}$	$\overline{DCS1}$		VCC	VCC			GD	GND		$\overline{QCS1B}$	QCS1A
<b>L</b>	RESET	D14		GND	GND			VCC	VCC		Q6B	Q6A
<b>M</b>	D0	D10		GND	GND			GND	GND		Q10B	Q10A
<b>N</b>	D17	D16		VCC	VCC			VCC	VCC		Q9B	Q9A
<b>P</b>	D19	D21		GND	VCC	VCC	VCC	VCC	GND		Q11B	Q11A
<b>R</b>	D13	D20		GND	VCC	VCC	GND	GND	GND		Q15B	Q15A
<b>T</b>	DODT1	DODT0									Q14B	Q14A
<b>U</b>	DCKE0	DCKE1	MCL <sup>(2)</sup>	$\overline{PTYERR}$	MCH <sup>(3)</sup>	Q3B	Q12B	Q7B	Q4A	Q13A	Q0B	Q8B
<b>V</b>	VREF	MCL	MCL	NC	MCH	Q3A	Q12A	Q7A	Q4B	Q13B	Q0A	Q8A

(1) NC denotes pins that have no internal connection

(2) MCL denotes pins that must be connected LOW

(3) MCH denotes pins that must be connected HIGH

LOGIC DIAGRAM

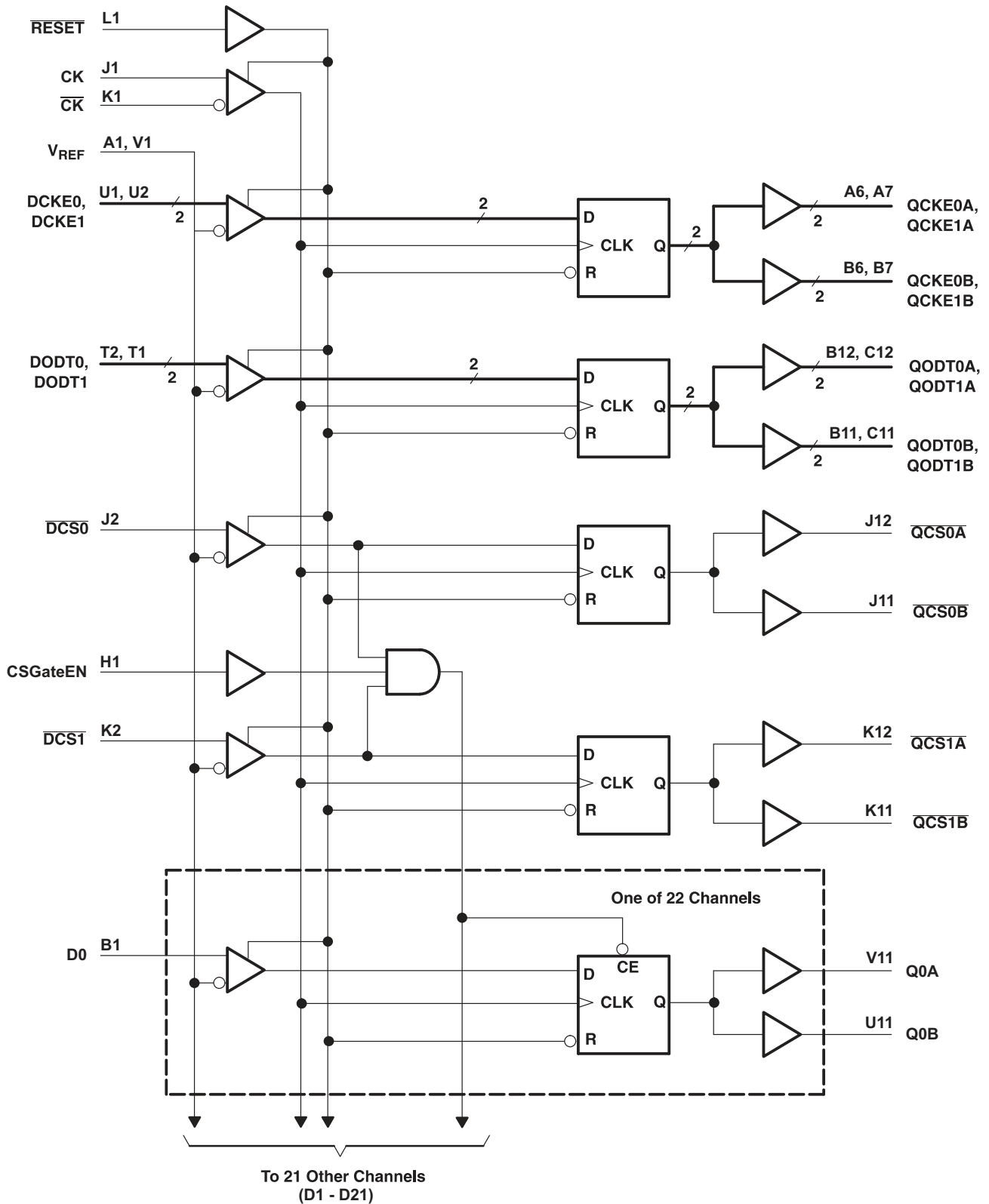

**PARITY LOGIC DIAGRAM**

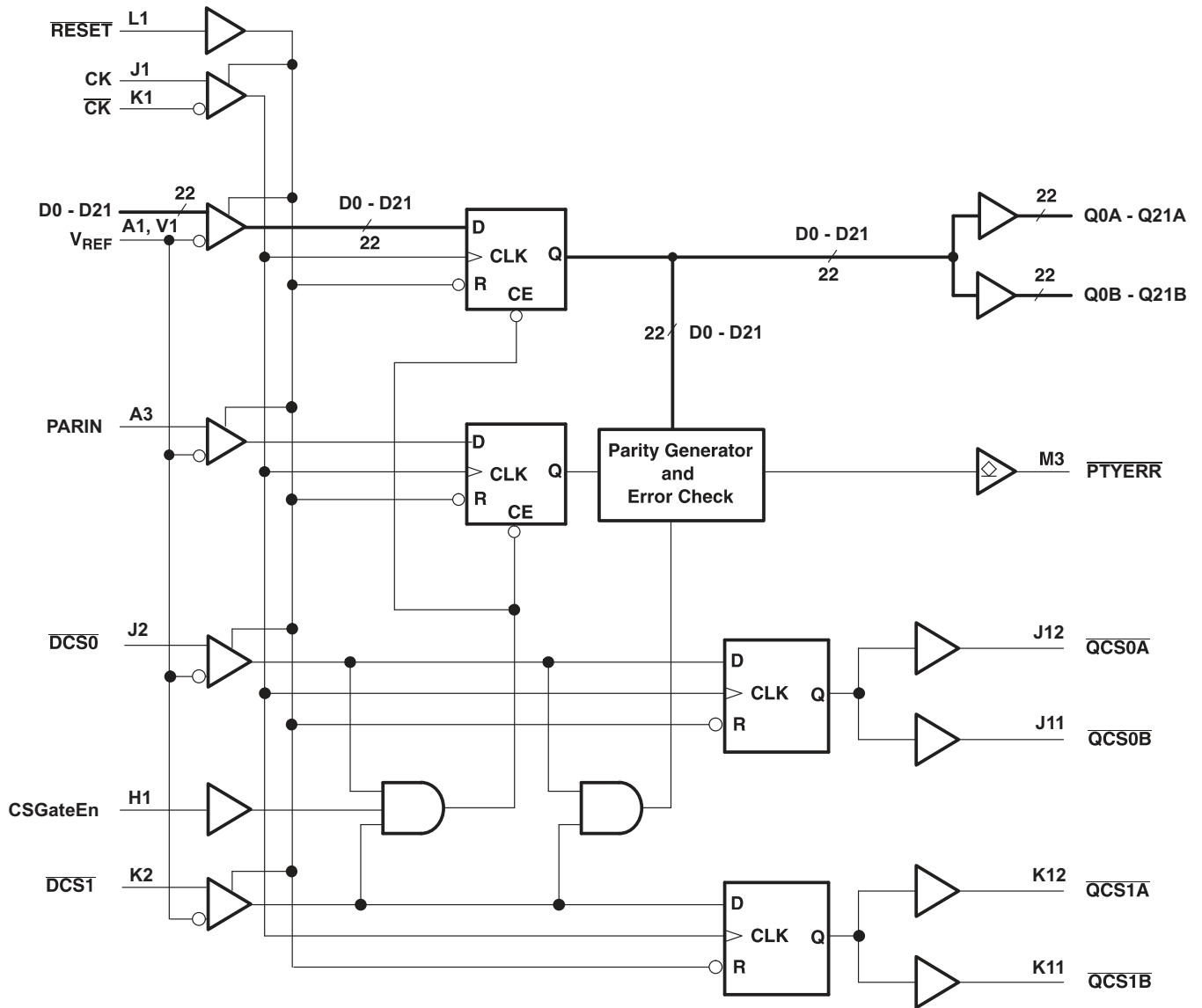

**TIMING DIAGRAM for 74SSTUB32865 DURING START-UP ( $\overline{\text{RESET}}$  switches from L to H)**

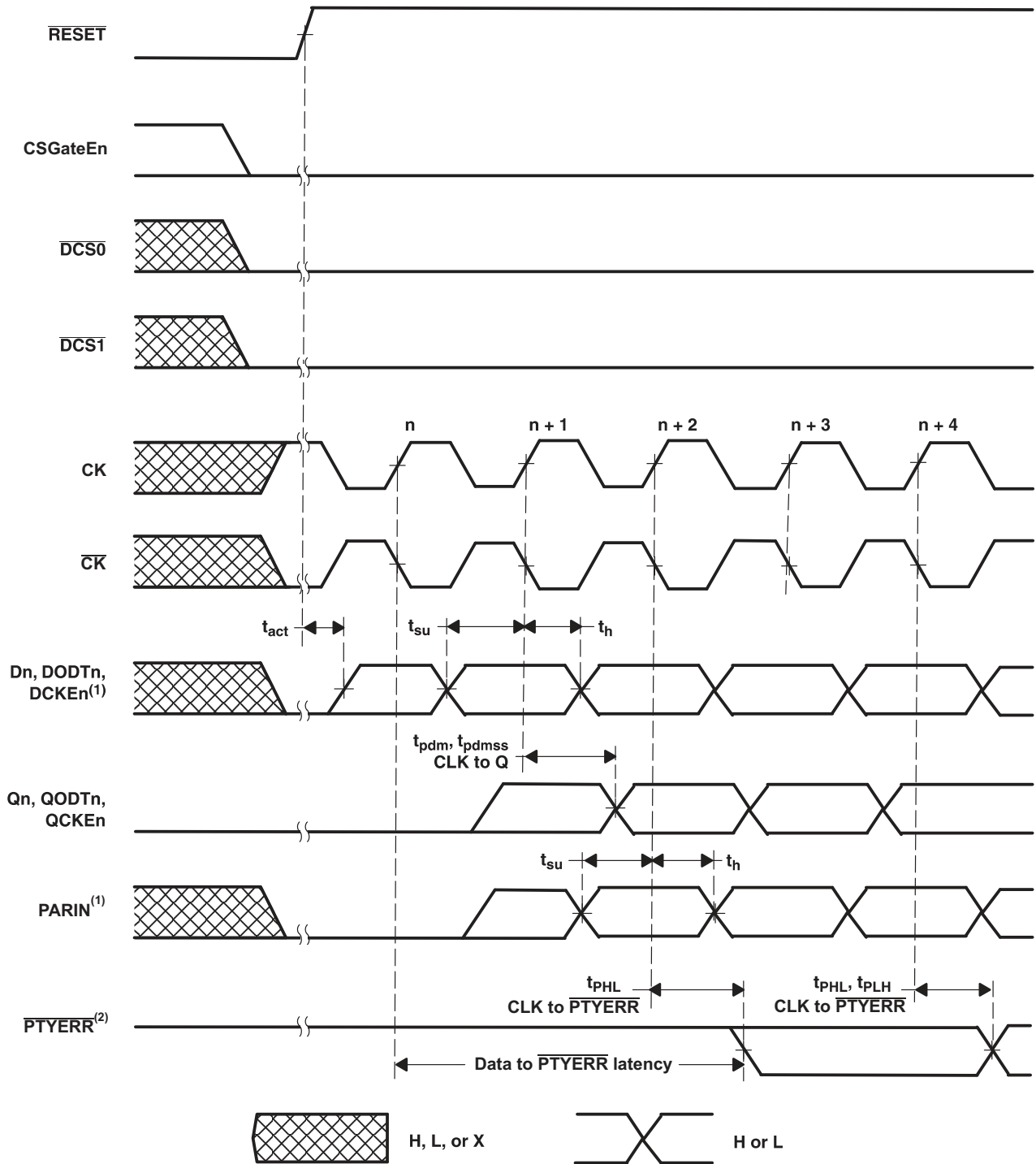

- (1) After  $\overline{\text{RESET}}$  is switched from low to high, all data and  $\text{PARIN}$  input signals must be set and held low for a minimum time of  $t_{\text{act}}$  max, to avoid false error.
- (2) If the data is clocked in on the  $n$  clock pulse, the  $\text{PTYERR}$  output signal will be generated on the  $n+2$  clock pulse and it will be valid on the  $n+3$  clock pulse.

**TIMING DIAGRAM for 74SSTUB32865 DURING NORMAL OPERATION (RESET = H)**

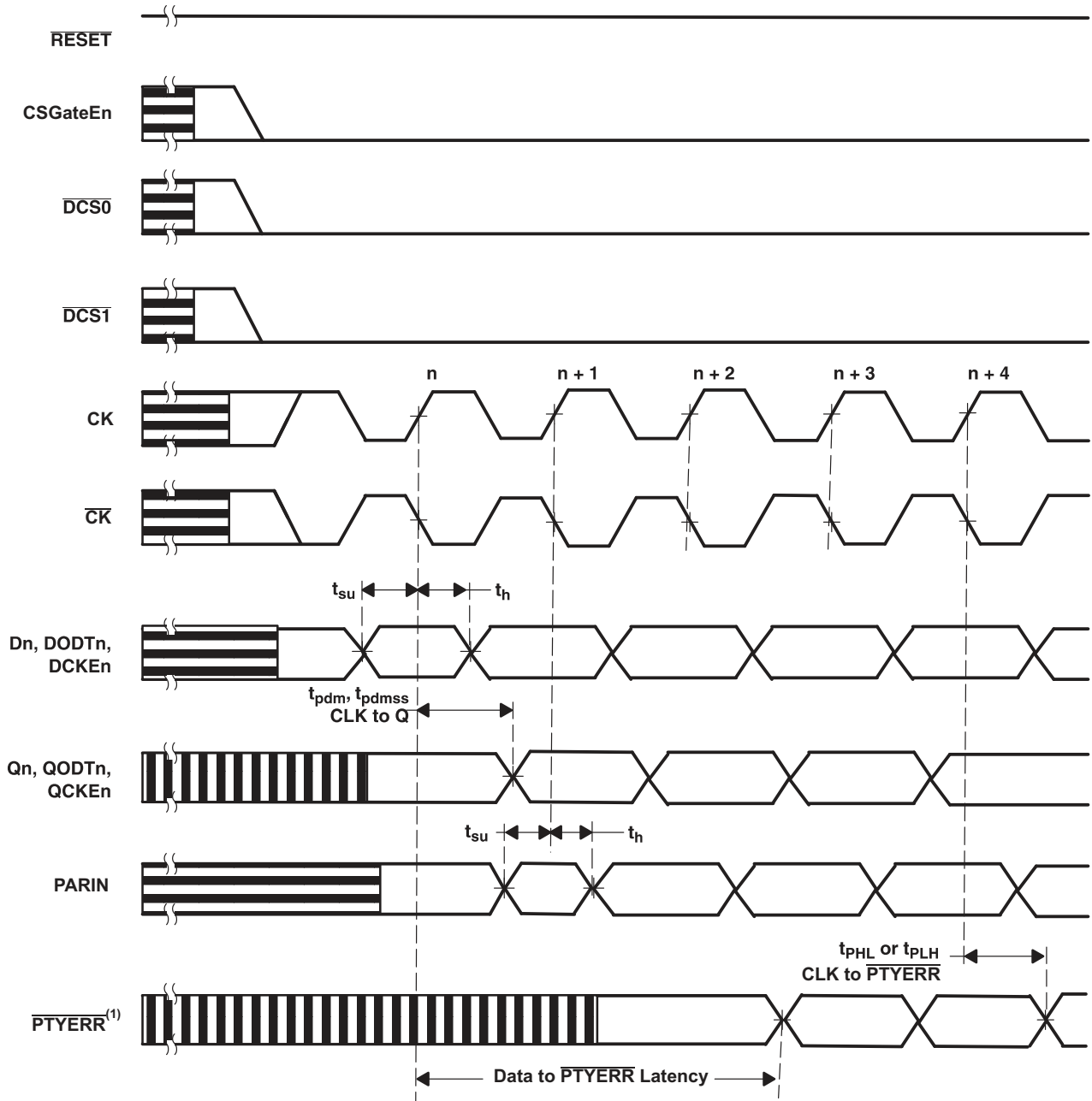

Unknown input event



Output signal is dependent on the prior unknown input event



H or L

(1) If the data is clocked in on the  $n$  clock pulse, the  $\overline{\text{PTYERR}}$  output signal is generated on the  $n + 2$  clock pulse and is valid on the  $n + 3$  clock pulse. If an error occurs and the  $\overline{\text{PTYERR}}$  output is driven low, it stays latched low for a minimum of two clock cycles or until  $\overline{\text{RESET}}$  is driven low.

**TIMING DIAGRAM for 74SSTUB32865 DURING SHUT-DOWN ( $\overline{\text{RESET}}$  switches from H to L)**

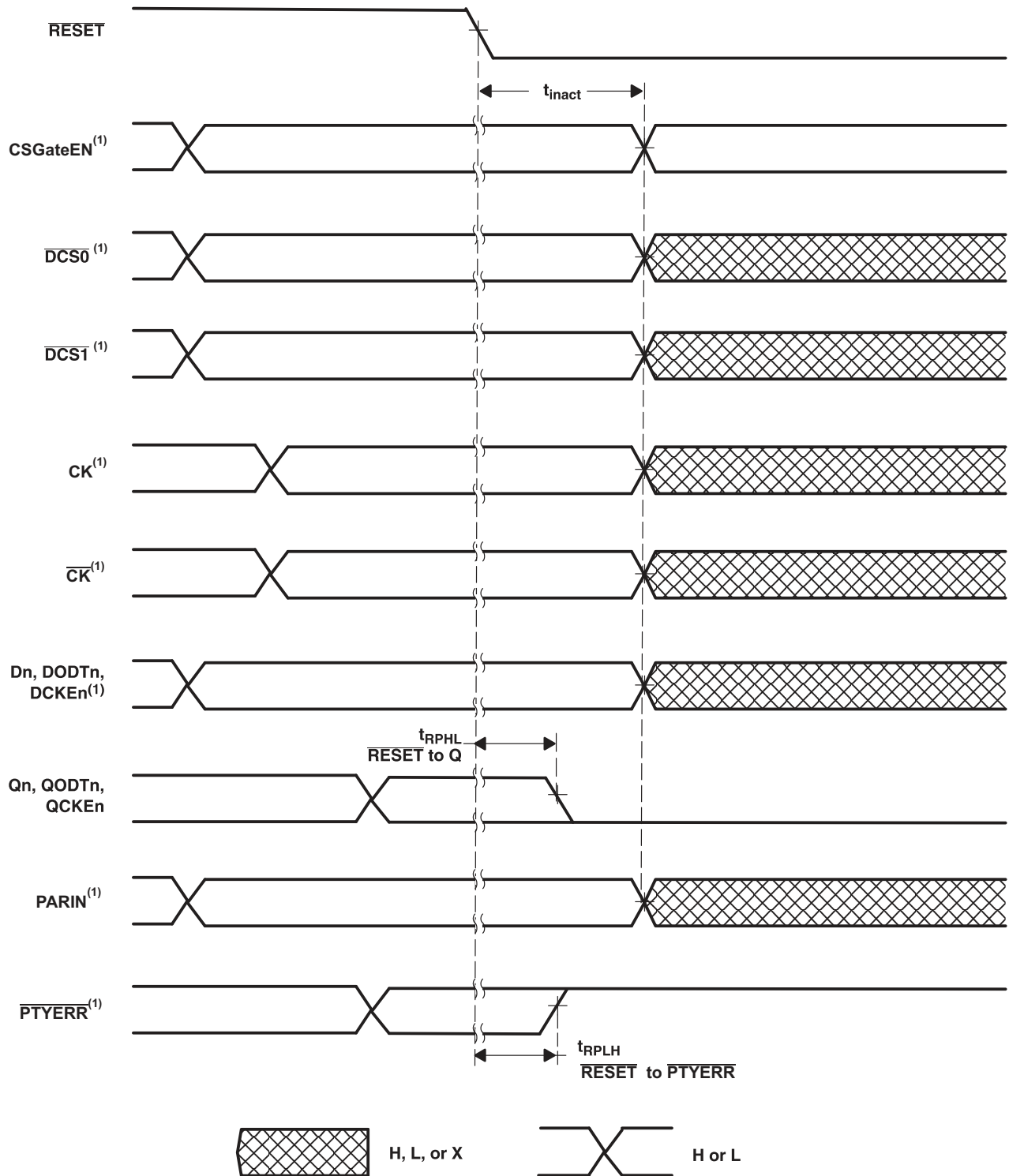

(1) After  $\overline{\text{RESET}}$  is switched from high to low, all data and clock input signals must be held at valid logic levels (not floating) for a minimum time of  $t_{\text{inact}}$  max.



**TERMINAL FUNCTIONS**

TERMINAL NAME	DESCRIPTION	ELECTRICAL CHARACTERISTICS
GND	Ground	Ground input
V <sub>CC</sub>	Power supply voltage	1.8 V nominal
VREF	Input reference voltage	0.9 V nominal
CK	Positive master clock input	Differential input
$\overline{CK}$	Negative master clock input	Differential input
$\overline{RESET}$	Asynchronous reset input – resets registers and disables V <sub>REF</sub> , data and clock differential-input receivers. When $\overline{RESET}$ is low, all the Q outputs are forced low and the PTYERR output is forced high.	LVC MOS input
CSGateEN	Chip select gate enable – When high, D0-D21 inputs will be latched only when at least one chip select input is low during the rising edge of the clock. When low, the D0-D21 inputs will be latched and redriven on every rising edge of the clock.	LVC MOS input
D0-D21	Data input – clocked in on the crossing of the rising edge of CK and the falling edge of $\overline{CK}$	SSTL <sub>18</sub> inputs
$\overline{DCS0}$ , $\overline{DCS1}$	Chip select inputs – These pins initiate DRAM address/command decodes, and as such at least one will be low when a valid address/command is present. The Register can be programmed to redrive all D inputs (CSGateEN high) only when at least one chip select input is low. If CSGateEN, $\overline{DCS0}$ , and $\overline{DCS1}$ inputs are high, D1-D28 <sup>(1)</sup> inputs will be disabled.	SSTL <sub>18</sub> inputs
$\overline{DODT0}$ , $\overline{DODT1}$	The outputs of this register bit will not be suspended by the $\overline{DCS0}$ and $\overline{DCS1}$ control.	SSTL <sub>18</sub> input
$\overline{DCKE0}$ , $\overline{DCKE1}$	The outputs of this register bit will not be suspended by the $\overline{DCS0}$ and $\overline{DCS1}$ control.	SSTL <sub>18</sub> input
PARIN	Parity input – arrives one clock cycle after the corresponding data input	SSTL <sub>18</sub> input
Q0A-Q21A, Q0B-Q21B	Data outputs that are suspended by the $\overline{DCS0}$ and $\overline{DCS1}$ control.	1.8 V CMOS outputs
$\overline{QCS0A}$ , $\overline{QCS1A}$ , $\overline{QCS0B}$ , $\overline{QCS1B}$	Data output that are not suspended by the $\overline{DCS0}$ and $\overline{DCS1}$ control.	1.8 V CMOS output
QODT0A, QODT1A, QODT0B, QODT1B	Data output that are not suspended by the $\overline{DCS0}$ and $\overline{DCS1}$ control.	1.8 V CMOS output
QCKE0A, QCKE1A, QCKE0B, QCKE0B	Data output that are not suspended by the $\overline{DCS0}$ and $\overline{DCS1}$ control.	1.8 V CMOS output
PTYERR	Output error bit – generated two clock cycles after the corresponding data is registered.	Open-drain output
MCL	Must be connected to logic LOW	
MCH	Must be connected to logic HIGH	
NC	No internal connection	

**FUNCTION TABLE**

INPUTS							OUTPUTS			
RESET	$\overline{DCS0}$	$\overline{DCS1}$	CSGateEN	CK	$\overline{CK}$	Dn, DODTn, DCKEn	Qn	$\overline{QCS0}$	$\overline{QCS1}$	QODT, QCKE
H	L	L	X	↑	↓	L	L	L	L	L
H	L	L	X	↑	↓	H	H	L	L	H
H	L	L	X	L or H	L or H	X	Q <sub>0</sub>	Q <sub>0</sub>	Q <sub>0</sub>	Q <sub>0</sub>
H	L	H	X	↑	↓	L	L	L	H	L
H	L	H	X	↑	↓	H	H	L	H	H
H	L	H	X	L or H	L or H	X	Q <sub>0</sub>	Q <sub>0</sub>	Q <sub>0</sub>	Q <sub>0</sub>
H	H	L	X	↑	↓	L	L	H	L	L
H	H	L	X	↑	↓	H	H	H	L	H
H	H	L	X	L or H	L or H	X	Q <sub>0</sub>	Q <sub>0</sub>	Q <sub>0</sub>	Q <sub>0</sub>
H	H	H	L	↑	↓	L	L	H	H	L
H	H	H	L	↑	↓	H	H	H	H	H

FUNCTION TABLE (continued)

INPUTS							OUTPUTS			
RESET	DCS0	DCS1	CSGateEN	CK	CK	Dn, DODTn, DCKEn	Qn	QCS0	QCST	QODT, QCKE
H	H	H	L	L or H	L or H	X	Q <sub>0</sub>	Q <sub>0</sub>	Q <sub>0</sub>	Q <sub>0</sub>
H	H	H	H	↑	↓	L	Q <sub>0</sub>	H	H	L
H	H	H	H	↑	↓	H	Q <sub>0</sub>	H	H	H
H	H	H	H	L or H	L or H	X	Q <sub>0</sub>	Q <sub>0</sub>	Q <sub>0</sub>	Q <sub>0</sub>
L	X or floating	X or floating	X or floating	X or floating	X or floating	X or floating	L	L	L	L

PARITY AND STANDBY FUNCTION

INPUTS							OUTPUT	
RESET	CK	CK	DCS0	DCS1	Σ OF INPUTS = H D1–D22	PARIN <sup>(1)</sup>	PTYERR <sup>(2)</sup>	
H	↑	↓	L	X	Even	L	H	
H	↑	↓	L	X	Odd	L	L	
H	↑	↓	L	X	Even	H	L	
H	↑	↓	L	X	Odd	H	H	
H	↑	↓	X	L	Even	L	H	
H	↑	↓	X	L	Odd	L	L	
H	↑	↓	X	L	Even	H	L	
H	↑	↓	X	L	Odd	H	H	
H	↑	↓	H	H	X	X	PTYERR <sub>0</sub> <sup>(3)</sup>	
H	L or H	L or H	X	X	X	X	PTYERR <sub>0</sub>	
L	X or floating	X or floating	X or floating	X or floating	X	X or floating		

(1) PARIN arrives one clock cycle after the data to which it applies.

(2) This transition assumes that PTYERR is high at the crossing of CK going high and CK going low. If PTYERR goes low, it stays latched low for a minimum of two clock cycles or until RESET is driven low. If two or more consecutive errors occur, the PTYERR output is driven low and latched low for a clock duration equal to the parity error duration or until RESET is driven low. For PTYERR computation CSGateEN is a *don't care*.

(3) If DCS0, DCS1 and CSGateEN are driven high, the device is placed in a low-power mode (LPM). If a parity error occurs on the clock cycle before the device enters the LPM and the PTYERR output is driven low, it stays latched low for the LPM duration plus two clock cycles or until RESET is driven low.

## ABSOLUTE MAXIMUM RATINGS

over operating free-air temperature range (unless otherwise noted) <sup>(1)</sup>

		VALUE	UNIT
V <sub>CC</sub>	Supply voltage range	–0.5 to 2.5	V
V <sub>I</sub>	Input voltage range <sup>(2)</sup> <sup>(3)</sup>	–0.5 to V <sub>CC</sub> + 0.5	V
V <sub>O</sub>	Output voltage range <sup>(2)</sup> <sup>(3)</sup>	–0.5 to V <sub>CC</sub> + 0.5	V
I <sub>IK</sub>	Input clamp current t(V <sub>I</sub> < 0 or V <sub>I</sub> > V <sub>CC</sub> )	±50	mA
I <sub>OK</sub>	Output clamp current (V <sub>O</sub> < 0 or V <sub>O</sub> > V <sub>CC</sub> )	±50	mA
I <sub>O</sub>	Continuous output current, I <sub>O</sub> (V <sub>O</sub> = 0 to V <sub>CC</sub> )	±50	mA
I <sub>CC</sub>	Continuous current through each V <sub>CC</sub> or GND	±100	mA
θ <sub>JA</sub>	Thermal resistance, junction-to-ambient <sup>(4)</sup>	No Airflow	51.2
		Airflow 200 ft/min	47.2
θ <sub>JC</sub>	Thermal resistance, junction-to-case <sup>(4)</sup>	No Airflow	29.7
T <sub>stg</sub>	Storage temperature range	–65 to 150	°C

- (1) Stresses beyond those listed under *absolute maximum ratings* may cause permanent damage to the device. These are stress ratings only, and functional operation of the device at these or any other conditions beyond those indicated under *recommended operating conditions* is not implied. Exposure to absolute-maximum-rated conditions for extended periods may affect device reliability.
- (2) The input and output negative-voltage ratings may be exceeded if the input and output clamp-current ratings are observed.
- (3) This value is limited to 2.5 V maximum.
- (4) The package thermal impedance is calculated in accordance with JESD 51-7.

## RECOMMENDED OPERATING CONDITIONS<sup>(1)</sup>

		MIN	NOM	MAX	UNIT
V <sub>CC</sub>	Supply voltage	1.7		1.9	V
V <sub>REF</sub>	Reference voltage	0.49 × V <sub>CC</sub>	0.5 × V <sub>CC</sub>	0.51 × V <sub>CC</sub>	V
V <sub>TT</sub>	Termination voltage	V <sub>REF</sub> –40 mV	V <sub>REF</sub>	V <sub>REF</sub> +40mV	V
V <sub>I</sub>	Input voltage	0		V <sub>CC</sub>	V
V <sub>IH</sub>	AC high-level input voltage	Data inputs, $\overline{\text{DCSn}}$ , PARIN		V <sub>REF</sub> +250 mV	V
V <sub>IL</sub>	AC low-level input voltage	Data inputs, $\overline{\text{DCSn}}$ , PARIN		V <sub>REF</sub> –250 mV	V
V <sub>IH</sub>	DC high-level input voltage	Data inputs, $\overline{\text{DCSn}}$ , PARIN		V <sub>REF</sub> +125 mV	V
V <sub>IL</sub>	DC low-level input voltage	Data inputs, $\overline{\text{DCSn}}$ , PARIN		V <sub>REF</sub> –125 mV	V
V <sub>IH</sub>	High-level input voltage	RESET, CSGateEN, C		0.65 × V <sub>CC</sub>	V
V <sub>IL</sub>	Low-level input voltage	RESET, CSGateEN, C		0.35 × V <sub>CC</sub>	V
V <sub>ICR</sub>	Common-mode input voltage range	CK, $\overline{\text{CK}}$		1.125	V
V <sub>I(PP)</sub>	Peak-to-peak input voltage	CK, $\overline{\text{CK}}$		600	mV
I <sub>OH</sub>	High-level output current	Q outputs		–8	mA
I <sub>OL</sub>	Low-level output current	Q outputs		8	mA
		PTYERR output		30	
T <sub>A</sub>	Operating free-air temperature	–40		85	°C

- (1) The RESET and Cn inputs of the device must be held at valid logic voltage levels (not floating) to ensure proper device operation. The differential inputs must not be floating unless RESET is low. Refer to the TI application report, *Implications of Slow or Floating CMOS Inputs* (SCBA004).

## ELECTRICAL CHARACTERISTICS

over recommended operating free-air temperature range (unless otherwise noted)

PARAMETER		TEST CONDITIONS	V <sub>CC</sub>	MIN	TYP <sup>(1)</sup>	MAX	UNIT
V <sub>OH</sub>	Q outputs	I <sub>OH</sub> = –100 μA	1.7 V to 1.9 V	V <sub>CC</sub> –0.2			V
		I <sub>OH</sub> = –6 mA	1.7 V	1.2			

- (1) All typical values are at V<sub>CC</sub> = 1.8 V, T<sub>A</sub> = 25°C.

**ELECTRICAL CHARACTERISTICS (continued)**

over recommended operating free-air temperature range (unless otherwise noted)

PARAMETER		TEST CONDITIONS	V <sub>CC</sub>	MIN	TYP <sup>(1)</sup>	MAX	UNIT
V <sub>OL</sub>	Q outputs	I <sub>OL</sub> = 100 μA	1.7 V to 1.9 V			0.2	V
		I <sub>OL</sub> = 6 mA	1.7 V			0.5	
	PTYERR output	I <sub>OL</sub> = 8 mA	1.7 V			0.45	
I <sub>I</sub>	PARIN	V <sub>I</sub> = GND	1.9 V			-5	μA
		V <sub>I</sub> = V <sub>CC</sub>				+25	
	All other inputs <sup>(2)</sup>	V <sub>I</sub> = V <sub>CC</sub> or GND				±5	
I <sub>OZ</sub>	PTYERR output	V <sub>O</sub> = V <sub>CC</sub> or GND	1.9 V			±10	μA
I <sub>CC</sub>	Static standby <sup>(3)</sup>	RESET = GND	1.9 V	I <sub>O</sub> = 0		200	μA
	Static operating	RESET = V <sub>CC</sub> , V <sub>I</sub> = V <sub>IH(AC)</sub> or V <sub>IL(AC)</sub>				80	
I <sub>CCD</sub>	Dynamic operating – clock only	RESET = V <sub>CC</sub> , V <sub>I</sub> = V <sub>IH(AC)</sub> or V <sub>IL(AC)</sub> , CK and CK switching 50% duty cycle	1.8 V	I <sub>O</sub> = 0		64	μA/MHz
	Dynamic operating – per each data input	RESET = V <sub>CC</sub> , V <sub>I</sub> = V <sub>IH(AC)</sub> or V <sub>IL(AC)</sub> , CK and CK switching 50% duty cycle, One data input switching at one half clock frequency, 50% duty cycle				37	
I <sub>CCDLP</sub>	Chip-select-enabled low-power active mode – clock only	RESET = V <sub>CC</sub> , V <sub>I</sub> = V <sub>IH(AC)</sub> or V <sub>IL(AC)</sub> , CK and CK switching 50% duty cycle	1.8 V	I <sub>O</sub> = 0		68	μA/MHz
	Chip-select-enabled low-power active model	RESET = V <sub>CC</sub> , V <sub>I</sub> = V <sub>IH(AC)</sub> or V <sub>IL(AC)</sub> , CK and CK switching 50% duty cycle, One data input switching at one half clock frequency, 50% duty cycle				2.7	
C <sub>I</sub> <sup>(4)</sup>	Input Capacitance, Data Inputs	V <sub>I</sub> = V <sub>REF</sub> ± 250 mV	1.8 V		2.5	3.5	pF
	Input Capacitance, CK and CK	V <sub>ICR</sub> = 0.9 V, V <sub>I(PP)</sub> = 600 mV			2	3	
	Input Capacitance, RESET	V <sub>I</sub> = V <sub>CC</sub> or GND				4	

(2) Each V<sub>REF</sub> pin (A1 or V1) should be tested independently, with the other (untested) pin open.(3) The maximum static standby current I<sub>CC</sub> is 100 μA if the device is exposed only to commercial temperature range (0°C to 70°C). For industrial temperature range (-40°C to 85°C) the maximum static I<sub>CC</sub> is 200 μA.

(4) Measured using TDR method and adjusted from substrate transmission line effects.

**TIMING REQUIREMENTS**over recommended operating free-air temperature range (unless otherwise noted) (see Figure 2 and Note <sup>(1)</sup>)

		V <sub>CC</sub> = 1.85 V ± 0.15 V		UNIT
		MIN	MAX	
f <sub>clock</sub>	Clock frequency		410	MHz
t <sub>w</sub>	Pulse duration, CK, CK high or low	1		ns
t <sub>act</sub>	Differential inputs active time <sup>(2)</sup>		10	ns
t <sub>inact</sub>	Differential inputs inactive time <sup>(3)</sup>		15	ns
t <sub>su</sub>	Setup time	D <sub>CSn</sub> before CK↑, CK↓, CSGateEN high	0.6	ns
		D <sub>CSn</sub> before CK↑, CK↓, CSGateEN low	0.5	
		DODTn, DCKEn, and Data before CK↑, CK↓	0.5	
		PARIN before CK↑, CK↓	0.5	
t <sub>h</sub>	Hold time	D <sub>CSn</sub> , DODTn, DCKEn, and Data after CK↑, CK↓	0.4	ns
		PARIN after CK↑, CK↓	0.4	

(1) All inputs slew rate is 1 V/ns ± 20%.

(2) V<sub>REF</sub> must be held at a valid input level and data inputs must be held low for a minimum time of t<sub>act</sub> max, after RESET is taken high.(3) V<sub>REF</sub>, data, and clock inputs must be held at valid voltage levels (not floating) for a minimum time of t<sub>inact</sub> max, after RESET is taken low.

## SWITCHING CHARACTERISTICS

over recommended operating free-air temperature range (unless otherwise noted)

PARAMETER	FROM (INPUT)	TO (OUTPUT)	$V_{CC} = 1.85\text{ V} \pm 0.15\text{ V}$		UNIT
			MIN	MAX	
$f_{\max}$ (see Figure 2)			410		MHz
$t_{\text{pdm}}^{(1)}$ (production test, see Figure 1)	CK and $\overline{\text{CK}}$	Q	0.5	1.1	ns
$t_{\text{PLH}}$ (see Figure 4)	CK and $\overline{\text{CK}}$	$\overline{\text{PTYERR}}$	1.2	3	ns
$t_{\text{PHL}}$ (see Figure 4)			1	2.4	ns
$t_{\text{RPHL}}^{(2)}$ (see Figure 2)	$\overline{\text{RESET}}$	Q		3	ns
$t_{\text{RPLH}}$ (see Figure 4)	RESET	$\overline{\text{PTYERR}}$		3	ns

(1) The typical difference between min and max does not exceed 400ps

(2) Includes 350 ps test-load transmission line delay.

## OUTPUT SLEW RATES

over recommended operating free-air temperature range (unless otherwise noted) (see Figure 3)

PARAMETER	FROM	TO	$V_{CC} = 1.85\text{ V} \pm 0.15\text{ V}$		UNIT
			MIN	MAX	
$dV/dt_r$	20%	80%	1	5	V/ns
$dV/dt_f$	80%	20%	1	5	V/ns
$dV/dt_{\Delta}^{(1)}$	20% or 80%	80% or 20%		1	V/ns

(1) Difference between  $dV/dt_r$  (rising edge rate) and  $dV/dt_f$  (falling edge rate).

## PARAMETER MEASUREMENT INFORMATION

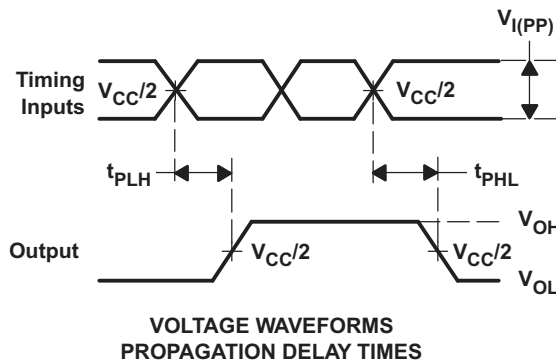
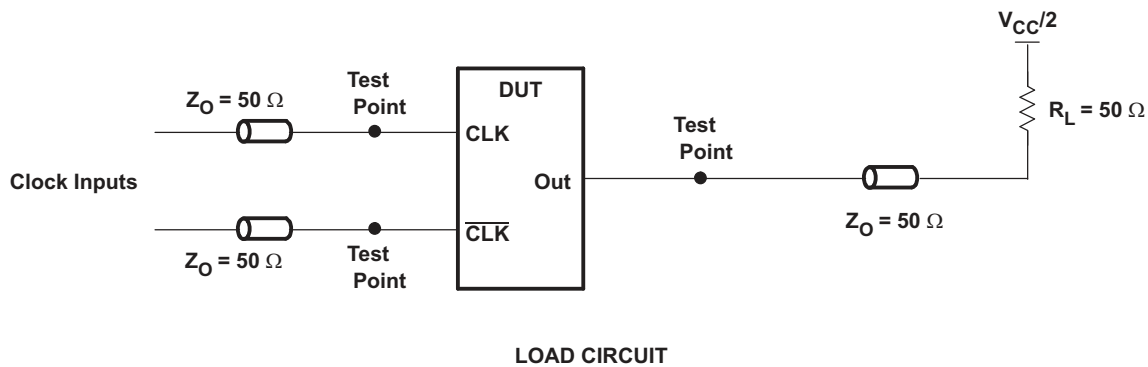
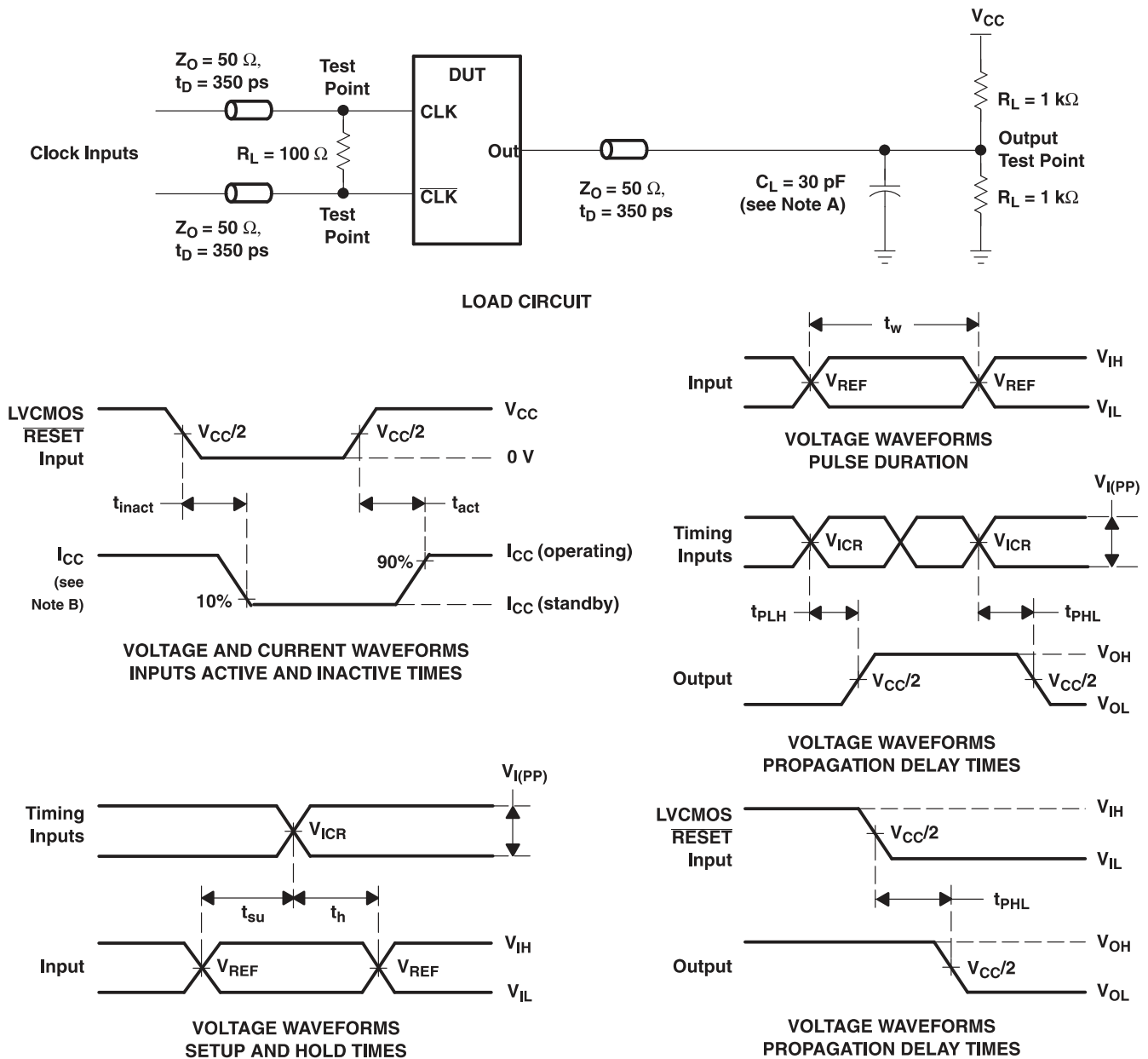

Figure 1. Output Load Circuit for Production Test

**PARAMETER MEASUREMENT INFORMATION (continued)**  
**Propagation Delay (Design Goal as per JEDEC Specification)**

PARAMETER	FROM (INPUT)	TO (OUTPUT)	$V_{CC} = 1.8\text{ V} \pm 0.1\text{ V}$		UNIT
			MIN	MAX	
$t_{pdm}^{(1)}$	CLK and $\overline{\text{CLK}}$	Q	1.1	1.5	ns
$t_{pdmss}^{(1)}$	CLK and $\overline{\text{CLK}}$	Q		1.6	ns

(1) Includes 350-ps test-load transmission line delay.



- NOTES:
- $C_L$  includes probe and jig capacitance.
  - $I_{CC}$  tested with clock and data inputs held at  $V_{CC}$  or GND, and  $I_O = 0 \text{ mA}$ .
  - All input pulses are supplied by generators having the following characteristics:  $PRR \leq 10 \text{ MHz}$ ,  $Z_O = 50 \Omega$ , input slew rate =  $1 \text{ V/ns} \pm 20\%$  (unless otherwise noted).
  - The outputs are measured one at a time with one transition per measurement.
  - $V_{REF} = V_{CC}/2$
  - $V_{IH} = V_{REF} + 250 \text{ mV}$  (ac voltage levels) for differential inputs.  $V_{IH} = V_{CC}$  for LVC MOS input.
  - $V_{IL} = V_{REF} - 250 \text{ mV}$  (ac voltage levels) for differential inputs.  $V_{IL} = \text{GND}$  for LVC MOS input.
  - $V_{I(PP)} = 600 \text{ mV}$
  - $t_{PLH}$  and  $t_{PHL}$  are the same as  $t_{pd}$ .

Figure 2. Data Output Load Circuit and Voltage Waveforms

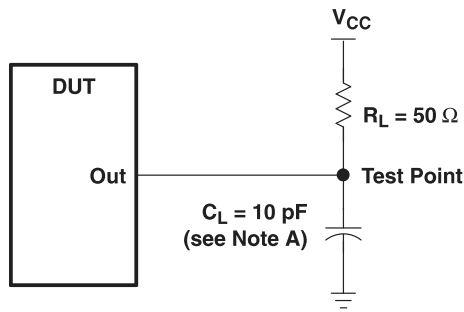

LOAD CIRCUIT  
HIGH-TO-LOW SLEW-RATE MEASUREMENT

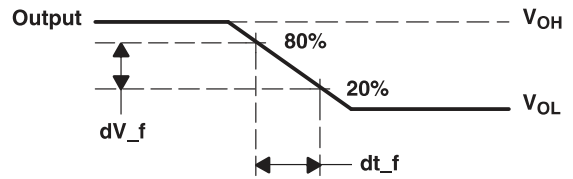

VOLTAGE WAVEFORMS  
HIGH-TO-LOW SLEW-RATE MEASUREMENT

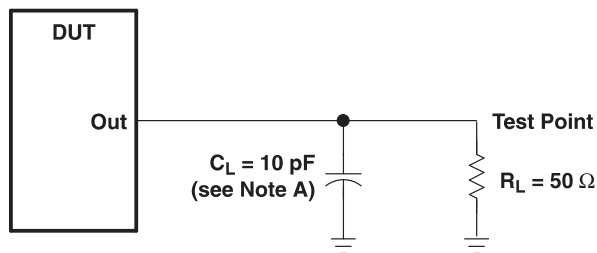

LOAD CIRCUIT  
LOW-TO-HIGH SLEW-RATE MEASUREMENT

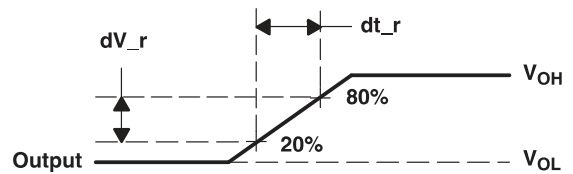

VOLTAGE WAVEFORMS  
LOW-TO-HIGH SLEW-RATE MEASUREMENT

- NOTES: A.  $C_L$  includes probe and jig capacitance.  
B. All input pulses are supplied by generators having the following characteristics:  
PRR  $\leq$  10 MHz,  $Z_O = 50 \Omega$ , input slew rate = 1 V/ns  $\pm$  20% (unless otherwise specified).

Figure 3. Data Output Slew-Rate Measurement Information



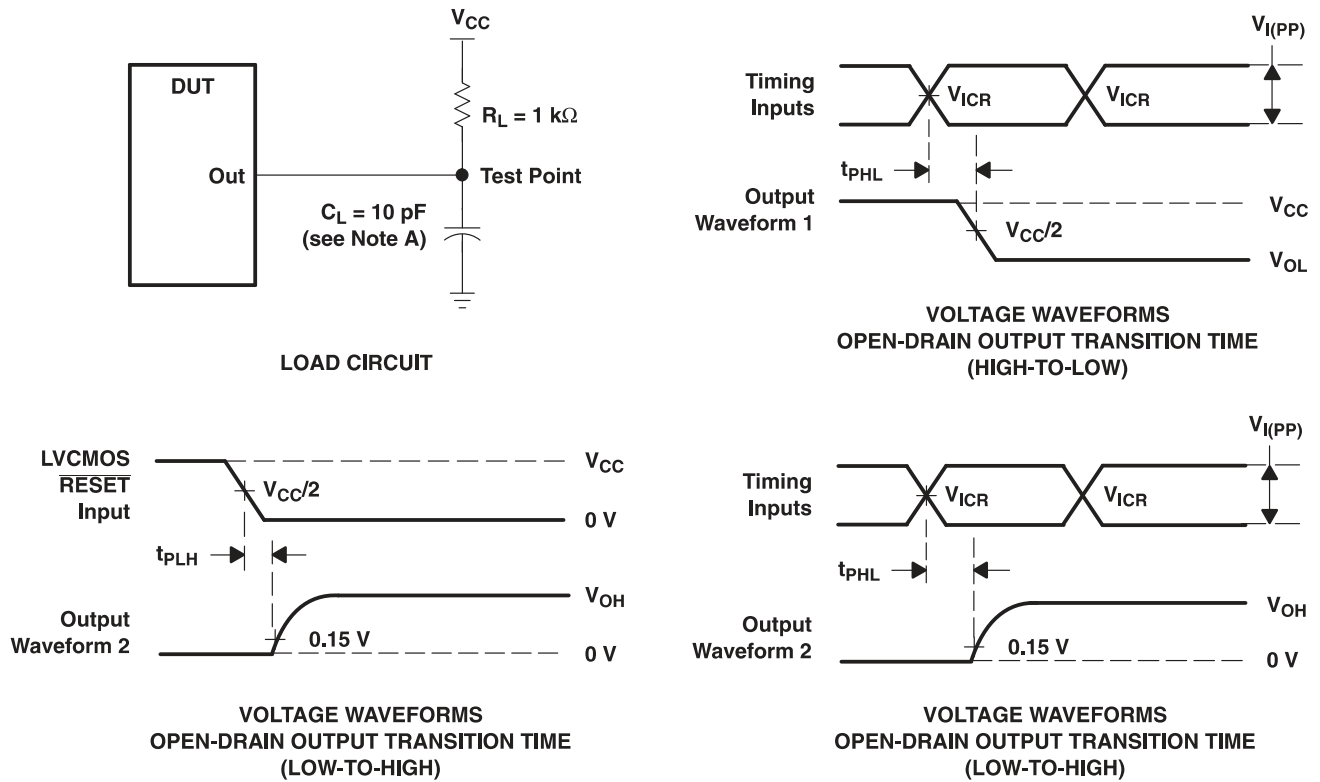

- NOTES:
- A.  $C_L$  includes probe and jig capacitance.
  - B. All input pulses are supplied by generators having the following characteristics:  $PRR \leq 10$  MHz,  $Z_O = 50 \Omega$ , input slew rate =  $1$  V/ns  $\pm 20\%$  (unless otherwise noted).
  - C.  $t_{PLH}$  and  $t_{PHL}$  are the same as  $t_{pd}$ .

**Figure 4. Error Output Load Circuit and Voltage Waveforms**

## TAPE AND REEL INFORMATION

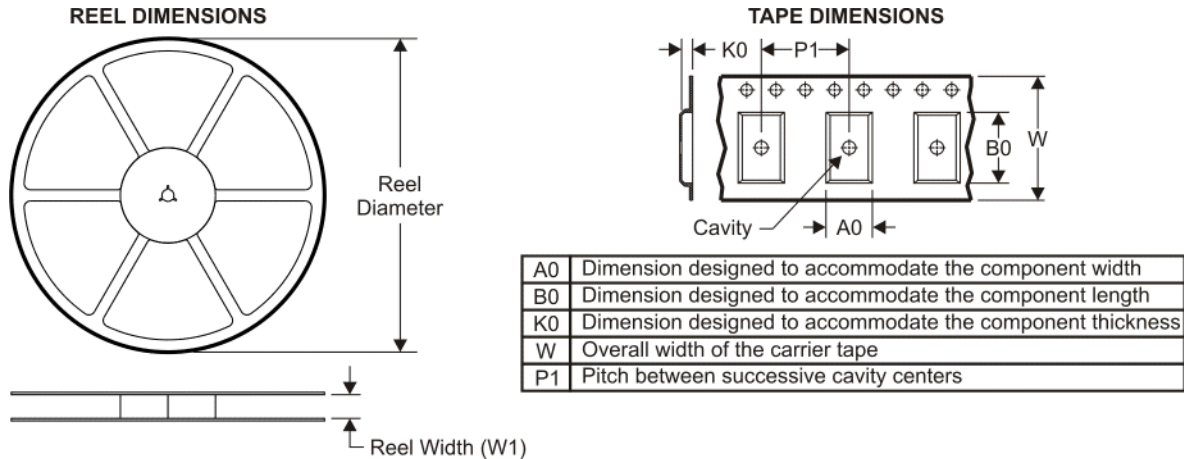

### QUADRANT ASSIGNMENTS FOR PIN 1 ORIENTATION IN TAPE

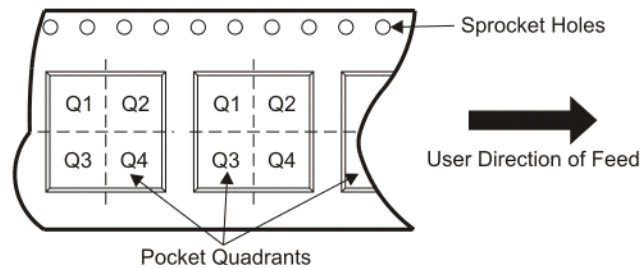

\*All dimensions are nominal

Device	Package Type	Package Drawing	Pins	SPQ	Reel Diameter (mm)	Reel Width W1 (mm)	A0 (mm)	B0 (mm)	K0 (mm)	P1 (mm)	W (mm)	Pin1 Quadrant
74SSTUB32865ZJBR	NFBGA	ZJB	160	1000	330.0	24.4	9.3	13.3	1.9	12.0	24.0	Q1

TAPE AND REEL BOX DIMENSIONS



\*All dimensions are nominal

Device	Package Type	Package Drawing	Pins	SPQ	Length (mm)	Width (mm)	Height (mm)
74SSTUB32865ZJBR	NFBGA	ZJB	160	1000	333.2	345.9	31.8

ZJB (R-PBGA-N160)

PLASTIC BALL GRID ARRAY

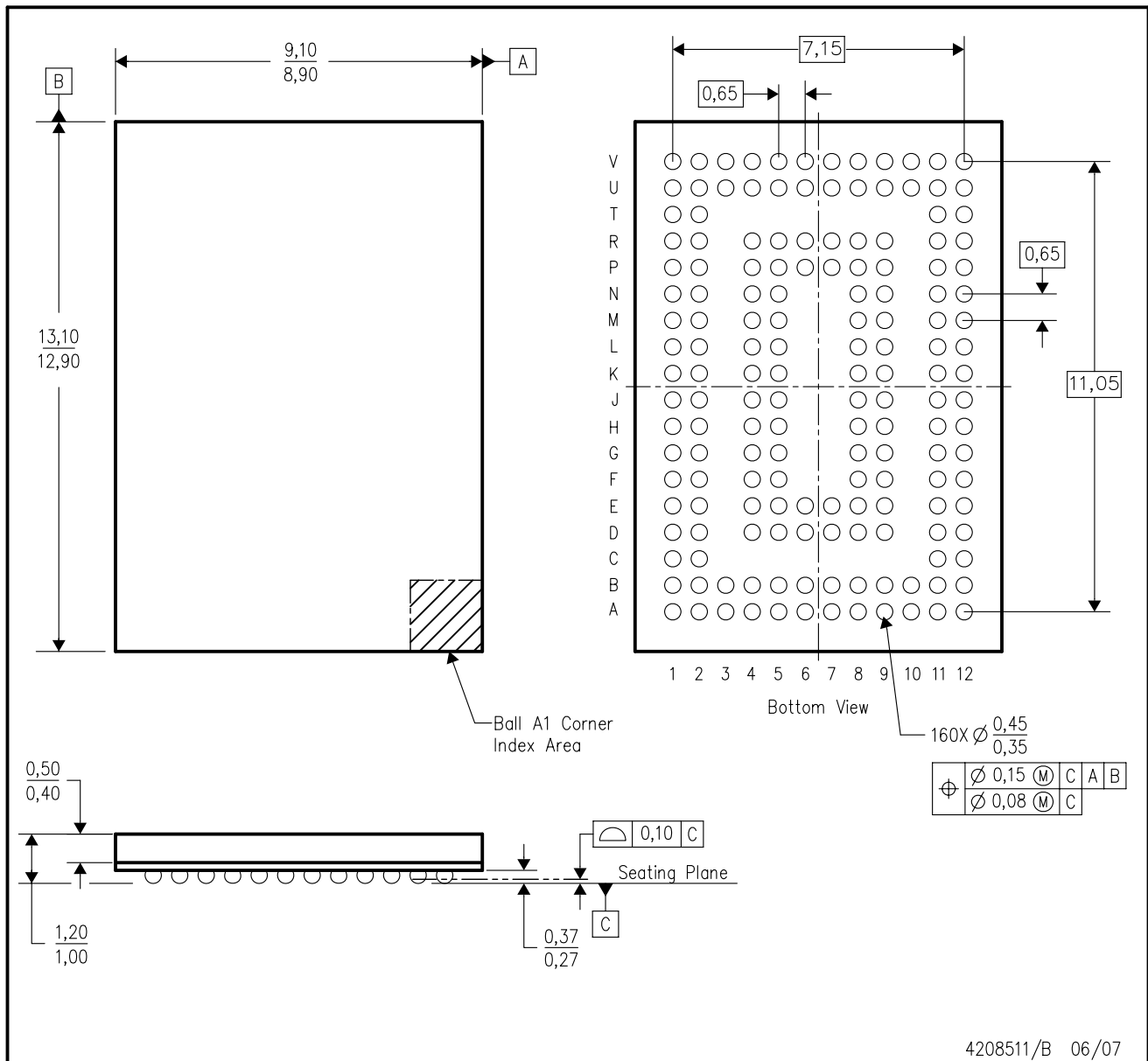

- NOTES:
- A. All linear dimensions are in millimeters. Dimensioning and tolerancing per ASME Y14.5M-1994.
  - B. This drawing is subject to change without notice.
  - C. This is a lead-free solder ball design.
  - D. Falls within Jedec MO 246

## IMPORTANT NOTICE

Texas Instruments Incorporated and its subsidiaries (TI) reserve the right to make corrections, modifications, enhancements, improvements, and other changes to its products and services at any time and to discontinue any product or service without notice. Customers should obtain the latest relevant information before placing orders and should verify that such information is current and complete. All products are sold subject to TI's terms and conditions of sale supplied at the time of order acknowledgment.

TI warrants performance of its hardware products to the specifications applicable at the time of sale in accordance with TI's standard warranty. Testing and other quality control techniques are used to the extent TI deems necessary to support this warranty. Except where mandated by government requirements, testing of all parameters of each product is not necessarily performed.

TI assumes no liability for applications assistance or customer product design. Customers are responsible for their products and applications using TI components. To minimize the risks associated with customer products and applications, customers should provide adequate design and operating safeguards.

TI does not warrant or represent that any license, either express or implied, is granted under any TI patent right, copyright, mask work right, or other TI intellectual property right relating to any combination, machine, or process in which TI products or services are used. Information published by TI regarding third-party products or services does not constitute a license from TI to use such products or services or a warranty or endorsement thereof. Use of such information may require a license from a third party under the patents or other intellectual property of the third party, or a license from TI under the patents or other intellectual property of TI.

Reproduction of TI information in TI data books or data sheets is permissible only if reproduction is without alteration and is accompanied by all associated warranties, conditions, limitations, and notices. Reproduction of this information with alteration is an unfair and deceptive business practice. TI is not responsible or liable for such altered documentation. Information of third parties may be subject to additional restrictions.

Resale of TI products or services with statements different from or beyond the parameters stated by TI for that product or service voids all express and any implied warranties for the associated TI product or service and is an unfair and deceptive business practice. TI is not responsible or liable for any such statements.

TI products are not authorized for use in safety-critical applications (such as life support) where a failure of the TI product would reasonably be expected to cause severe personal injury or death, unless officers of the parties have executed an agreement specifically governing such use. Buyers represent that they have all necessary expertise in the safety and regulatory ramifications of their applications, and acknowledge and agree that they are solely responsible for all legal, regulatory and safety-related requirements concerning their products and any use of TI products in such safety-critical applications, notwithstanding any applications-related information or support that may be provided by TI. Further, Buyers must fully indemnify TI and its representatives against any damages arising out of the use of TI products in such safety-critical applications.

TI products are neither designed nor intended for use in military/aerospace applications or environments unless the TI products are specifically designated by TI as military-grade or "enhanced plastic." Only products designated by TI as military-grade meet military specifications. Buyers acknowledge and agree that any such use of TI products which TI has not designated as military-grade is solely at the Buyer's risk, and that they are solely responsible for compliance with all legal and regulatory requirements in connection with such use.

TI products are neither designed nor intended for use in automotive applications or environments unless the specific TI products are designated by TI as compliant with ISO/TS 16949 requirements. Buyers acknowledge and agree that, if they use any non-designated products in automotive applications, TI will not be responsible for any failure to meet such requirements.

Following are URLs where you can obtain information on other Texas Instruments products and application solutions:

### Products

Amplifiers	<a href="http://amplifier.ti.com">amplifier.ti.com</a>
Data Converters	<a href="http://dataconverter.ti.com">dataconverter.ti.com</a>
DLP® Products	<a href="http://www.dlp.com">www.dlp.com</a>
DSP	<a href="http://dsp.ti.com">dsp.ti.com</a>
Clocks and Timers	<a href="http://www.ti.com/clocks">www.ti.com/clocks</a>
Interface	<a href="http://interface.ti.com">interface.ti.com</a>
Logic	<a href="http://logic.ti.com">logic.ti.com</a>
Power Mgmt	<a href="http://power.ti.com">power.ti.com</a>
Microcontrollers	<a href="http://microcontroller.ti.com">microcontroller.ti.com</a>
RFID	<a href="http://www.ti-rfid.com">www.ti-rfid.com</a>
RF/IF and ZigBee® Solutions	<a href="http://www.ti.com/lprf">www.ti.com/lprf</a>

### Applications

Audio	<a href="http://www.ti.com/audio">www.ti.com/audio</a>
Automotive	<a href="http://www.ti.com/automotive">www.ti.com/automotive</a>
Broadband	<a href="http://www.ti.com/broadband">www.ti.com/broadband</a>
Digital Control	<a href="http://www.ti.com/digitalcontrol">www.ti.com/digitalcontrol</a>
Medical	<a href="http://www.ti.com/medical">www.ti.com/medical</a>
Military	<a href="http://www.ti.com/military">www.ti.com/military</a>
Optical Networking	<a href="http://www.ti.com/opticalnetwork">www.ti.com/opticalnetwork</a>
Security	<a href="http://www.ti.com/security">www.ti.com/security</a>
Telephony	<a href="http://www.ti.com/telephony">www.ti.com/telephony</a>
Video & Imaging	<a href="http://www.ti.com/video">www.ti.com/video</a>
Wireless	<a href="http://www.ti.com/wireless">www.ti.com/wireless</a>

Mailing Address: Texas Instruments, Post Office Box 655303, Dallas, Texas 75265  
Copyright © 2009, Texas Instruments Incorporated