

Notes :

- \* Body : High temperature plastic UL 94V-0, Color Nature(Halogen-Free)
- \* Slider : High temperature plastic UL 94V-0, Color Black(Halogen-Free)
- \* Contact : Phosphor Bronze, With Matte Tin plated
- \* Fixed tab : Brass, With Matte Tin plated
- \* For Lead-Free IR Reflow process

Ordering Code

CF20 \*\* 1 V 0 R 0 -NH  
 ① ② ③ ④ ⑤ ⑥ ⑦ ⑧

- ① Series No.
- ② No. of Circuits
- ③ Plating code:  
 1 = 3.05μm(120μ") Min. Matte Tin over 0.76μm(30μ") Nickel
- ④ Contact style: V= Vertical Type
- ⑤ Color: 0= Nature
- ⑥ Packing Type:  
 R= Tape & Reel; T= Tube Packing
- ⑦ Other options: 0 = Standard
- ⑧ NH= For Lead Free IR Processes and Halogen-Free

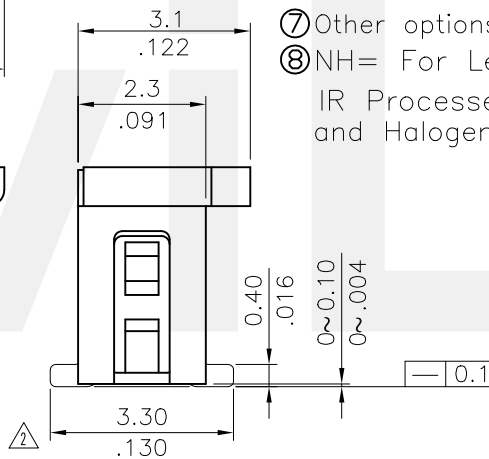
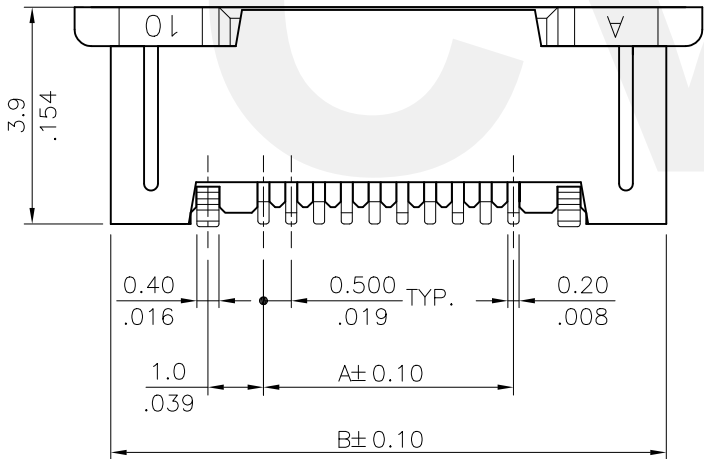
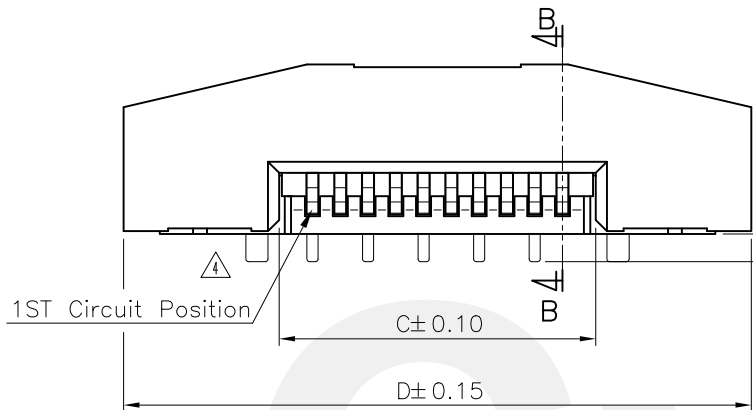

A = 0.50 x No. of Spaces  
 B = A + 5.5  
 C = A + 1.2  
 D = A + 6.8

\* Available in 4 through 50 circuits

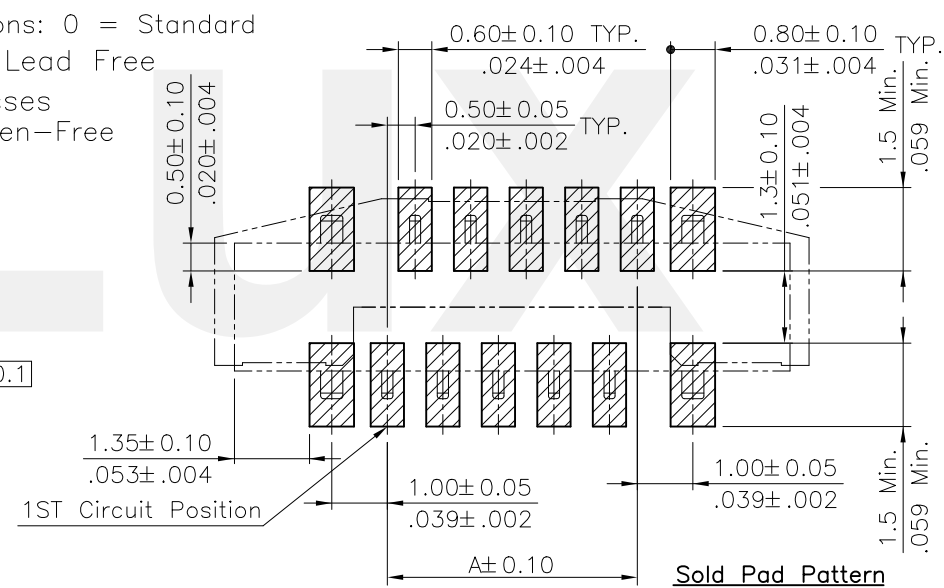
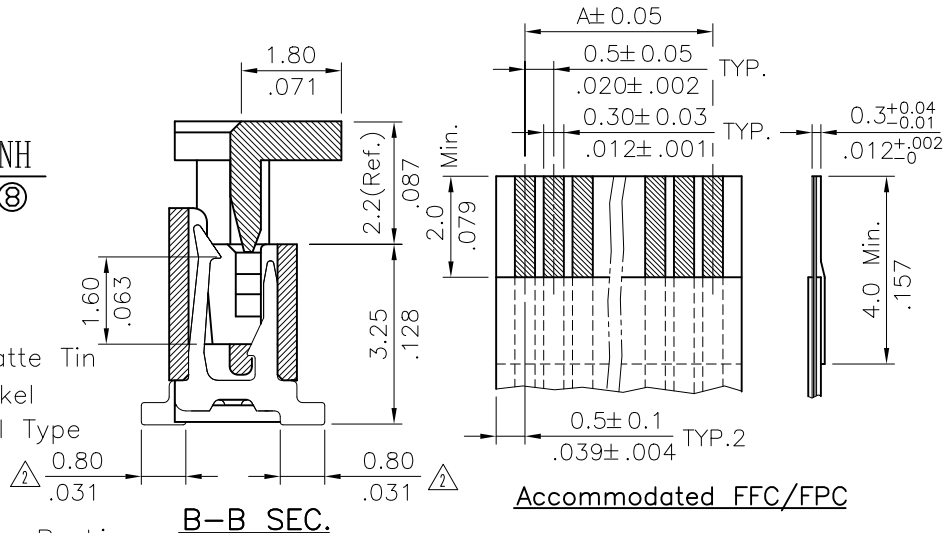

Halogen-Free Lead Free Process RoHS compliant

④	Sandy	4/7-17'	ECNT117082		DATE	UNIT: mm / inch	TITLE: 0.50mm(.031") ZIF FFC/FPC VERTICAL TYPE SURFACE MOUNT CONNECTOR	瀚荃股份有限公司 CviLux Corporation
③	Karen	11/11-13'	ECNT113116	DRAWN BY: Sandy	4/11-17'	TOLERANCE UNLESS OTHERWISE SPECIFIED	MATERIAL:	
②	Una	8/11-10'	ECN10283	ENGINEER: Sun	4/12-17'	.X ± 0.15/.006 .X' ± .1	CUSTOMER:	PART NO. CF20**1V0*0-NH
①	Karen	10/17-08'	ECN08363	CHECKED BY: Eisley	4/19-17'	.XX ± 0.10/.004 .X' ±		SHEET 1 OF 2
SYM	NAME	DATE	REVISIONS	APPROVED BY: Eisley	4/19-17'	.XXX ± 0.05/.002 .XX' ±		SCALE 7 / 1

CVILUX CORP  
 2017.04.20  
 ISSUED

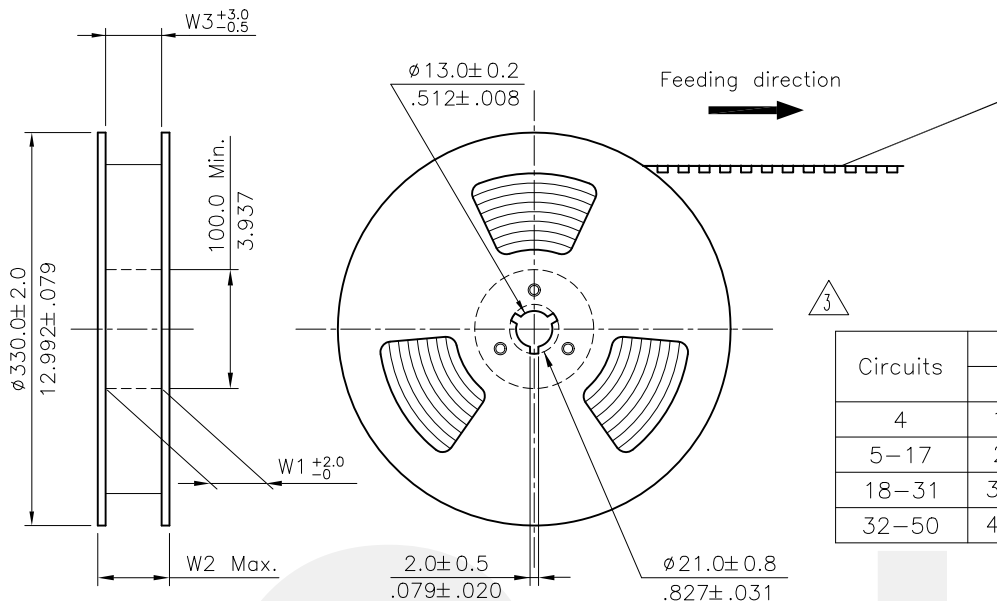

NOTE :

- \* Reel Material : Corrugated Paper
- \* Carrier Material : Clear, Conductive Polystyrene Alloy
- \* Cover Tape Material : Polyester
- \* Cover Tape Peel Strength : 0.1N – 1.3N
- \* Carrier camber is within 1mm in 100mm
- \* All dimensions meet EIA-481-2 & EIA-481-3 requirements.
- \* Quantity : 1000 PCS/Reel

Circuits	Dimension					Packing (Reel/Carton)
	E	F	W1	W2	W3	
4	16.0(.630)	—	16.5(.650)	22.5(.886)	16.5(.650)	11
5-17	24.0(.945)	—	24.5(.965)	30.5(1.200)	24.5(.965)	9
18-31	32.0(1.260)	28.40(1.118)	32.5(1.280)	38.5(1.516)	32.5(1.280)	7
32-50	44.0(1.732)	40.40(1.596)	44.5(1.752)	50.5(1.988)	44.5(1.752)	5

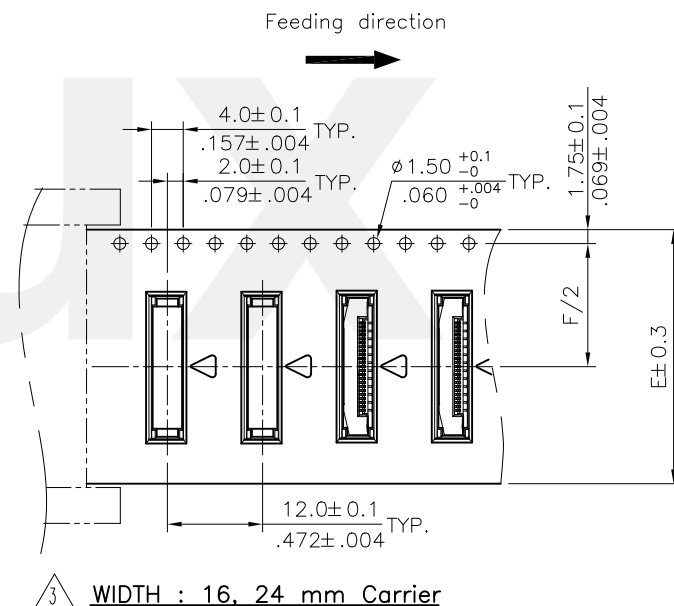
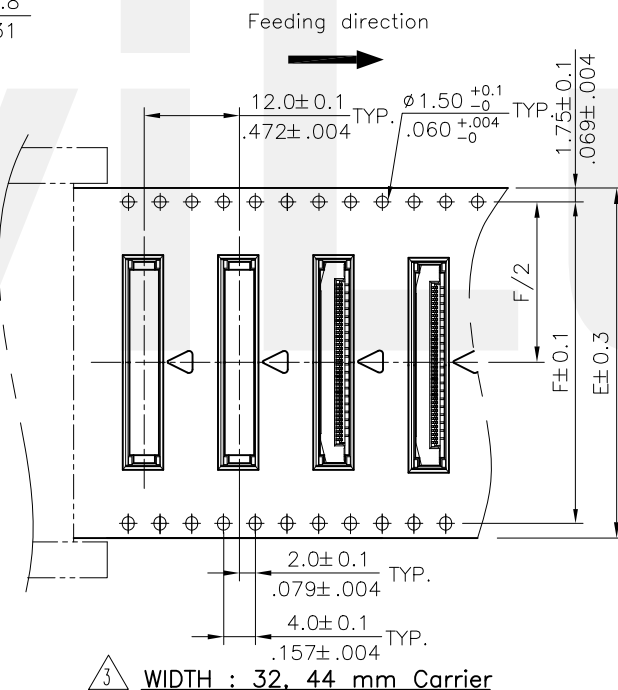
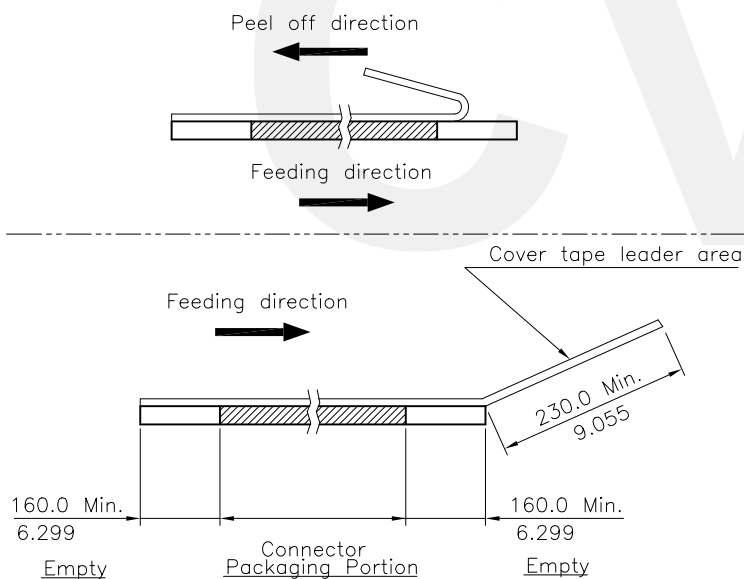

RoHS Compliant

4	Sandy	4/7-17'	ECNT117082		DATE	UNIT: mm / inch	TITLE: 0.50mm(.031") ZIF FFC/FPC VERTICAL TYPE SURFACE MOUNT CONNECTOR	 瀚荃股份有限公司 CviLux Corporation	
3	Karen	11/11-13'	ECNT113116	DRAWN BY: Sandy	4/11-17'	TOLERANCE UNLESS OTHERWISE SPECIFIED	MATERIAL:		
2	Una	8/11-10'	ECN10283	ENGINEER: Sun	4/12-17'	.X ±	.X' ± 1'	DRAWING NO. CF2081SE	
1	Karen	10/17-08'	ECN08363	CHECKED BY: Eisley	4/19-17'	.XX ±	.X ±		PART NO. CF20**1V0*0-NH
SYM	NAME	DATE	REVISIONS	APPROVED BY: Eisley	4/19-17'	.XXX ±	.XX ±	SCALE	SHEET 2 OF 2

CVILUX CORP  
2017.04.20  
ISSUED