

100V, ADJUSTABLE CURRENT SINK LINEAR LED DRIVER

Description

The AL5801 combines a 100V N-channel MOSFET with a pre-biased NPN transistor to make a simple, small footprint LED driver.

The LED current is set by an external resistor connected from R_{EXT} pin (4) to GND pin (6). The internal pre-biased transistor develops approximately 0.56V across the external resistor.

The AL5801 open-drain output can operate from 1.1V to 100V enabling it to operate 5V to 100V power supplies without additional components.

PWM dimming of the LED current can be achieved by driving the BIAS pin (1) with an external, open-collector NPN transistor or open-drain N-channel MOSFET.

The AL5801 is available in a SOT26 package and is ideal for driving LED currents up to 350mA.

Pin Assignments

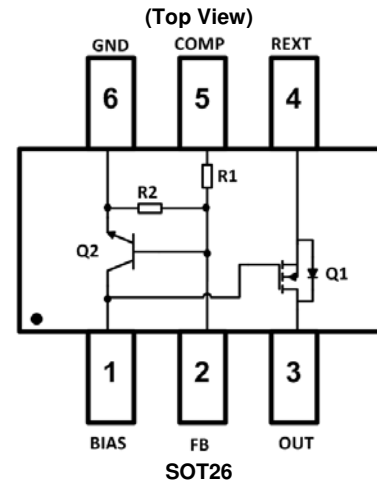

Features

- Feedback Pin Reference Voltage $V_{RSET} = 0.56V$ at $+25^{\circ}C$
- $-40^{\circ}C$ to $+125^{\circ}C$ Temperature Range
- 1.1V to 100V Open-Drain Output
- Negative temperature V_{RSET} co-efficient automatically reduces the LED current at high temperatures
- Low thermal impedance SOT26 package with copper lead frame
- **Lead-Free Finish; RoHS Compliant (Notes 1 & 2)**
- **Halogen and Antimony Free. "Green" Device (Note 3)**
- **Qualified to AEC-Q101 Standards for High Reliability**

Applications

- Linear LED Drivers
- LED Signs
- Offline LED Luminaries

Notes: 1. EU Directive 2002/95/EC (RoHS) & 2011/65/EU (RoHS 2) compliant. All applicable RoHS exemptions applied.
 2. See <http://www.diodes.com> for more information about Diodes Incorporated's definitions of Halogen- and Antimony-free, "Green" and Lead-free.
 3. Halogen- and Antimony-free "Green" products are defined as those which contain <900ppm bromine, <900ppm chlorine (<1500ppm total Br + Cl) and <1000ppm antimony compounds.

Typical Applications Circuit

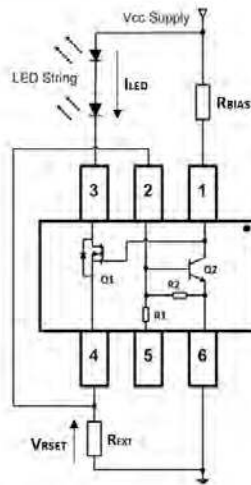

Pin Descriptions

Pin Number	Pin Name	Function
1	BIAS	Biases the open-Drain output MOSFET
2	FB	Feedback pin
3	OUT	Open-Drain LED driver output
4	R _{EXT}	Current sense pin. LED current sensing resistor should be connected from here to GND
5	COMP	Compensation pin. Connect COMP pin to REXT pin and insert a 1nF ceramic capacitor from COMP pin to FB pin for improved transient stability
6	GND	Ground reference point for setting the LED current

Functional Block Diagram

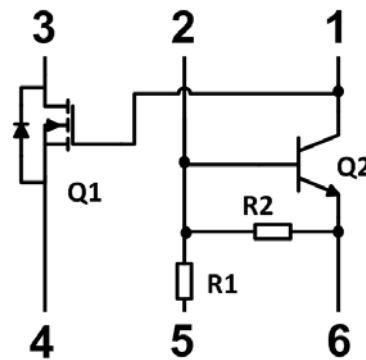

Figure 1 Block Diagram

Absolute Maximum Ratings (@T_A = +25°C, unless otherwise specified.)

Symbol	Characteristics	Values	Unit
V _{OUT}	Output voltage relative to GND	100	V
V _{BIAS}	BIAS voltage relative to GND (Note 4)	20	V
V _{FB}	FB voltage relative to GND	6	V
V _{COMP}	COMP voltage relative to GND	6	V
V _{REXT}	REXT voltage relative to GND	6	V
I _{OUT}	Output current	350	mA
T _J	Operating junction temperature	-40 to +150	°C
T _{ST}	Storage temperature	-55 to +150	°C

Note: 4. With pins 5 and 6 connected together.

These are stress ratings only. Operation outside the absolute maximum ratings may cause device failure. Operation at the absolute maximum rating for extended periods may reduce device reliability.

Package Thermal Data

Characteristic	Symbol	Value	Unit
Power Dissipation (Note 5) @ $T_A = +25^\circ\text{C}$	P _D	0.75	W
Power Dissipation (Note 6) @ $T_A = +25^\circ\text{C}$		0.70	
Power Dissipation (Note 7) @ $T_A = +25^\circ\text{C}$		0.85	
Power Dissipation (Note 8) @ $T_A = +25^\circ\text{C}$		1.05	
Thermal Resistance, Junction to Ambient Air (Note 5) @ $T_A = +25^\circ\text{C}$	R _{θJA}	165	°C/W
Thermal Resistance, Junction to Ambient Air (Note 6) @ $T_A = +25^\circ\text{C}$		180	
Thermal Resistance, Junction to Ambient Air (Note 7) @ $T_A = +25^\circ\text{C}$		145	
Thermal Resistance, Junction to Ambient Air (Note 8) @ $T_A = +25^\circ\text{C}$		120	

Notes: 5. Device mounted on 15mm x 15mm 2oz copper board.
6. Device mounted on 25mm x 25mm 1oz copper board.
7. Device mounted on 25mm x 25mm 2oz copper board.
8. Device mounted on 50mm x 50mm 2oz copper board.

Recommended Operating Conditions (@ $T_A = +25^\circ\text{C}$, unless otherwise specified.)

Symbol	Parameter	Min	Max	Unit
V _{BIAS}	Supply voltage range	3.5	20	V
V _{OUT}	OUT voltage range	1.1	100	
I _{LED}	LED pin current (Note 9)	25	350	mA
T _A	Operating ambient temperature range	-40	125	°C

Note: 9. Subject to ambient temperature, power dissipation and PCB.

NMOSFET Electrical Characteristics: (Q1) (@ $T_A = +25^\circ\text{C}$, unless otherwise specified.)

Characteristic	Symbol	Min	Typ	Max	Unit	Test Condition
OFF CHARACTERISTICS						
Drain-Source Breakdown Voltage	BV _{DSS}	100	—	—	V	V _{GS} = 0V, I _D = 250μA
Zero Gate Voltage Drain Current	I _{DSS}	—	—	1	μA	V _{DS} = 60V, V _{GS} = 0V
Gate-Source Leakage	I _{GSS}	—	—	±100	nA	V _{GS} = ±20V, V _{DS} = 0V
ON CHARACTERISTICS						
Gate Threshold Voltage	V _{GS(th)}	2.0	—	4.1	V	V _{DS} = V _{GS} , I _D = 250μA
Static Drain-Source On-Resistance	R _{DS(ON)}	—	—	0.85 0.99	Ω	V _{GS} = 10V, I _D = 1.5A V _{GS} = 6V, I _D = 1A
Forward Transconductance	g _{fs}	—	0.9	—	S	V _{DS} = 15V, I _D = 1A
Diode Forward Voltage	V _{SD}	—	0.89	1.1	V	V _{GS} = 0V, I _S = 1.5A
DYNAMIC CHARACTERISTICS						
Input Capacitance	C _{iss}	—	129	—	pF	V _{DS} = 50V, V _{GS} = 0V f = 1.0MHz
Output Capacitance	C _{oss}	—	14	—	pF	
Reverse Transfer Capacitance	C _{rss}	—	8	—	pF	

Pre-Bias Transistor Electrical Characteristics: (Q2) (@ $T_A = +25^\circ\text{C}$, unless otherwise specified.)

Characteristic (Note 10)	Symbol	Min	Typ	Max	Unit	Test Condition
Input Voltage	$V_{I(off)}$	0.4	-	-	V	$V_{CC} = 5V, I_O = 100\mu A$
	$V_{I(on)}$	-	-	1.5	V	$V_{CC} = 0.3V, I_O = 5mA$
Output Voltage	$V_{O(on)}$	-	0.05	0.3	V	$I_O/I_I = 5mA/0.25mA$
Output Current	$I_{O(off)}$	-	-	0.5	μA	$V_{CC} = 50V, V_I = 0V$
DC Current Gain	G_1	80	-	-	-	$V_O = 5V, I_O = 10mA$
Input Resistance	R_1	3.2	4.7	6.2	$k\Omega$	-
Resistance Ratio	R_2/R_1	8	10	12	-	-

Notes: 10. Short duration pulse test used to minimize self-heating effect.

Thermal Characteristics

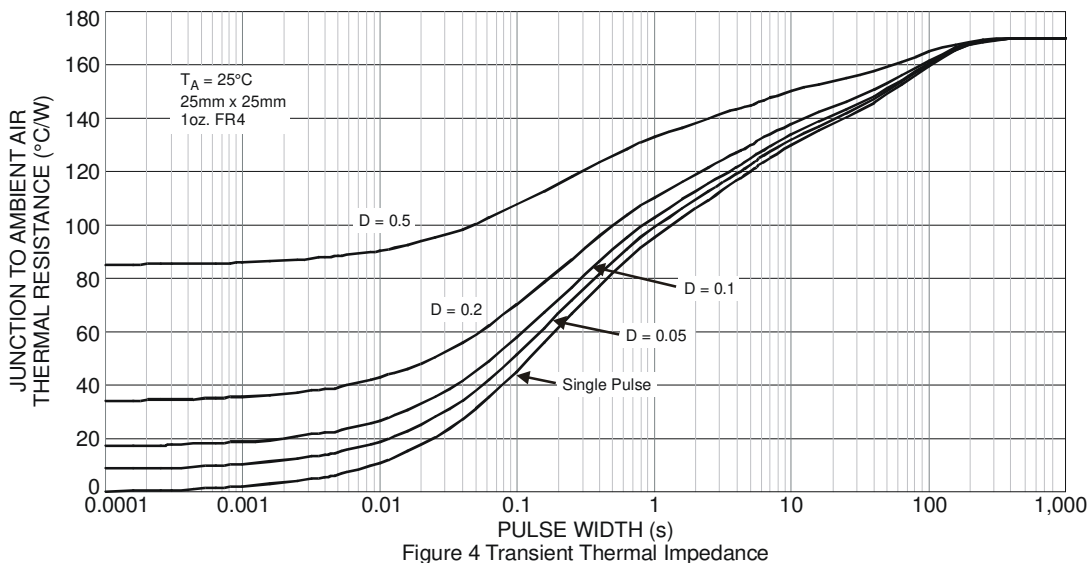
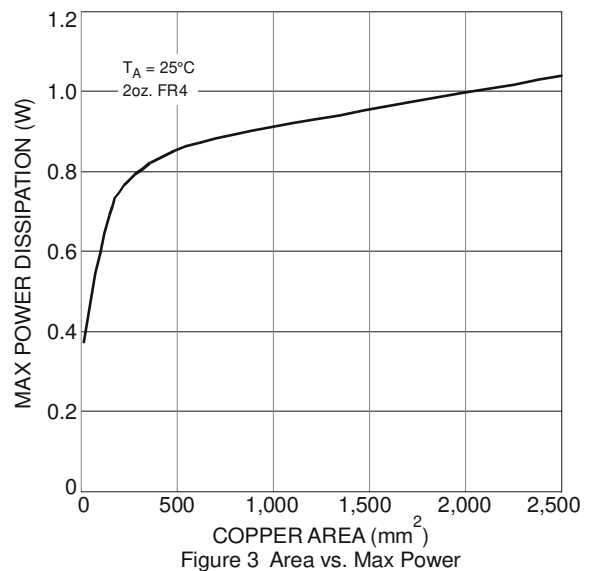
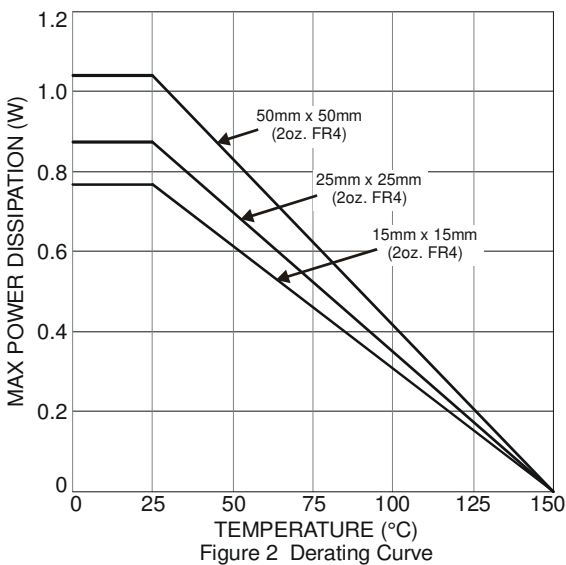

Typical Performance Characteristics

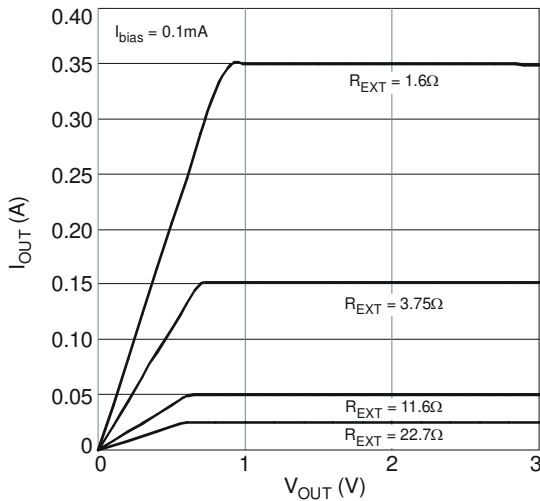

Figure 5 Output Current vs. V_{OUT}

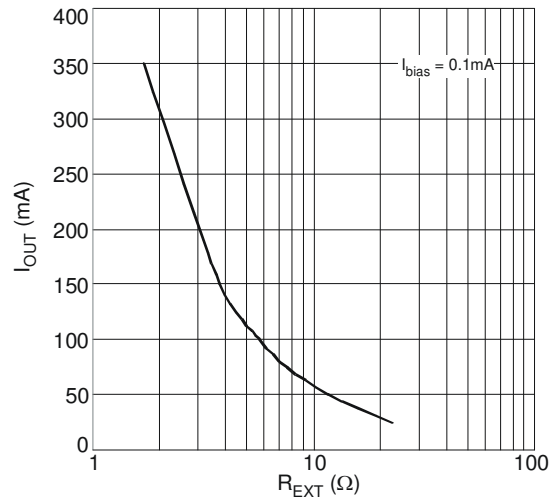

Figure 6 Output Current vs. R_{EXT}

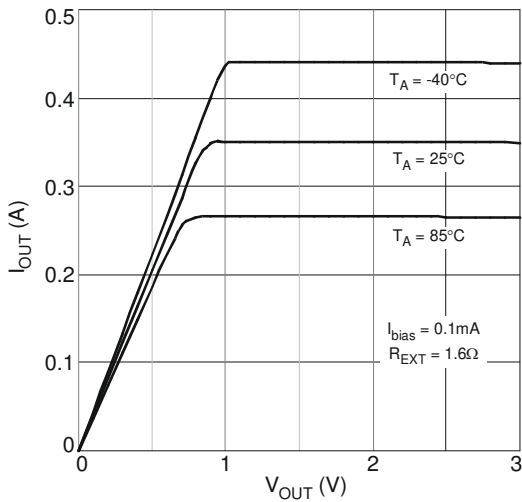

Figure 7 Output Current vs. V_{OUT}

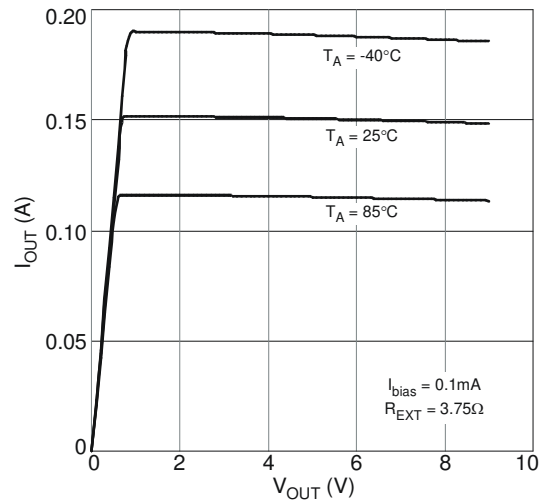

Figure 8 Output Current vs. V_{OUT}

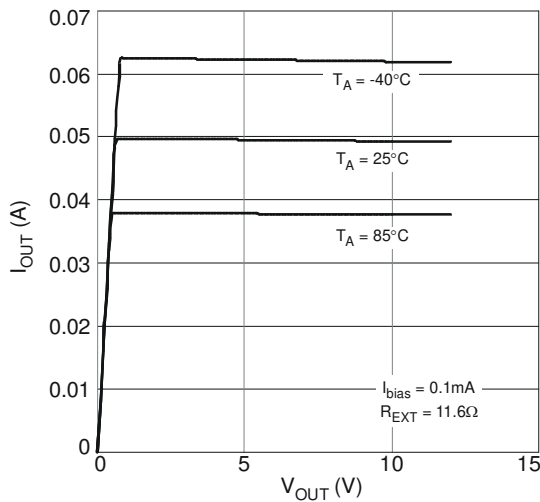

Figure 9 Output Current vs. V_{OUT}

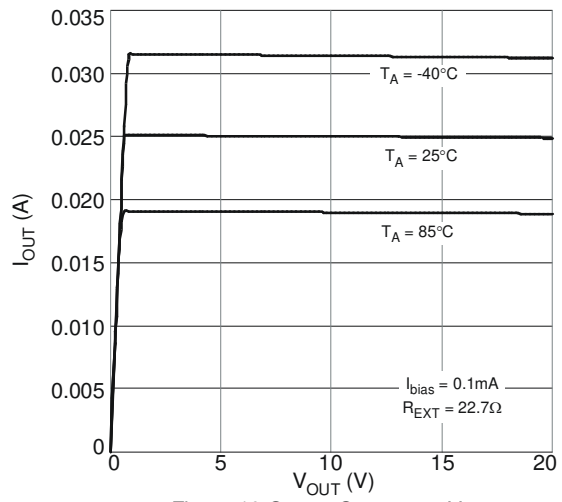
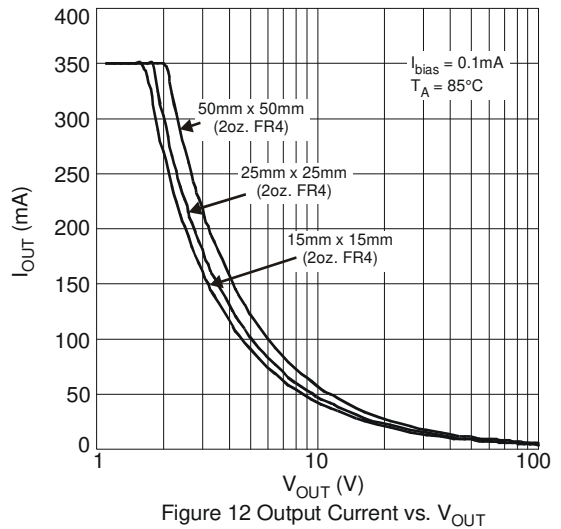
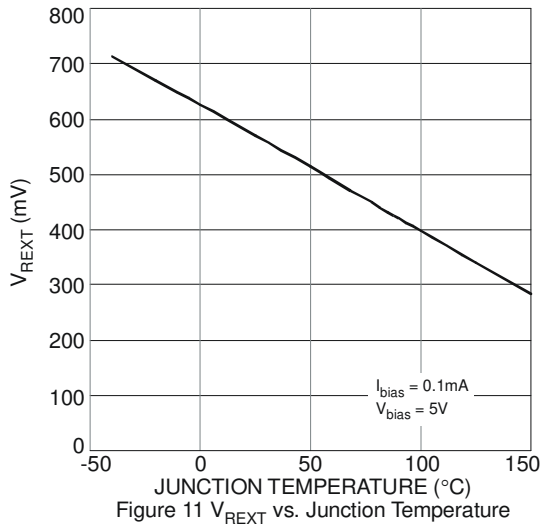

Figure 10 Output Current vs. V_{OUT}

Typical Performance Characteristics (cont.)



Application Information

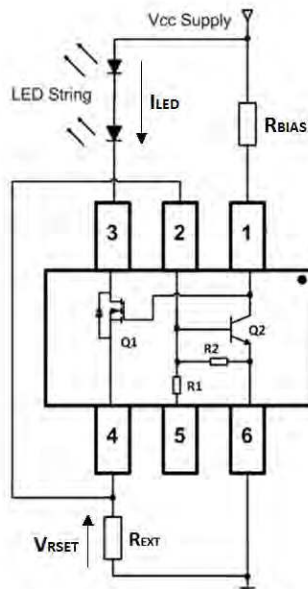

Figure 13 Typical Application Circuit for Linear Mode Current Sink LED Driver

The AL5801 is designed for driving high brightness LEDs with typical LED current up to 350mA. It provides a more cost effective way for driving low current LEDs when compared against more complex switching regulator solutions. Furthermore, it reduces the PCB board area of the solution because there is no need for external components like inductors, capacitors and/or switching diodes.

Figure 13 shows a typical application circuit diagram for driving an LED or a string of LEDs. The NPN transistor Q2 measures the LED current by sensing the voltage across an external resistor R_{EXT} . Q2 uses its V_{BE} as reference to set the voltage across R_{EXT} and controls the gate voltage of MOSFET Q1. Q1 operates in linear mode to regulate the LED current. The LED current is:

$$I_{LED} = V_{RSET} / R_{EXT}$$

where V_{RSET} is the V_{BE} of Q2. V_{BE} is 0.56V typical at a +25°C device temperature. See Figure 11 for the variation of V_{BE} with Q2's junction temperature at $I_{BIAS} = 0.1mA$. V_{BE} has a negative temperature coefficient which reduces the LED current as the device warms up, protecting the LED(s).

R_{BIAS} should be chosen to drive 0.1mA current into the BIAS pin

$$R_{BIAS} = (V_{CC} - 3.75V) / 0.1mA$$

From the above equation, for any required LED current the necessary external resistor R_{EXT} can be calculated from

$$R_{EXT} = V_{RSET} / I_{LED}$$

The expected linear mode power dissipation must be factored into the design consideration. The power dissipation across the device can be calculated by taking the maximum supply voltage less the minimum voltage across the LED string.

$$V_{DS(Q1)} = V_{CC(max)} - V_{LED(min)} - V_{RSET}$$

$$P_D = V_{DS(Q1)} * I_{LED}$$

As the output LED current of AL5801 increases so will its power dissipation. The power dissipation will cause the device temperature to rise above ambient, T_A , by an amount determined by the package thermal resistance, $R_{\theta JA}$.

Therefore, the power dissipation supported by the device is dependent upon the PCB board material, the copper area and the ambient temperature. The maximum dissipation the device can handle is given by:

$$P_D = (T_{J(MAX)} - T_A) / R_{\theta JA}$$

$T_{J(MAX)} = +150^\circ C$ is the maximum device junction temperature. Refer to the thermal characteristic graphs in Figure 2 to 4 for selecting the appropriate PCB copper area. Figure 12 shows the current capabilities of the AL5801 at +25°C with different PCB copper area heat sinks.

Constant LED Current Temperature Compensation

Variation in the junction temperature of Q2 will cause variations in the value of controlled LED current I_{LED} . The base-emitter V_{BE} voltage of Q2 decreases with increasing temperature at a rate of approximately 2mV/°C. Figure 14 shows a simple temperature compensation network, which comprises of an NTC thermistor and resistor R_{base} , for stabilizing the LED current.

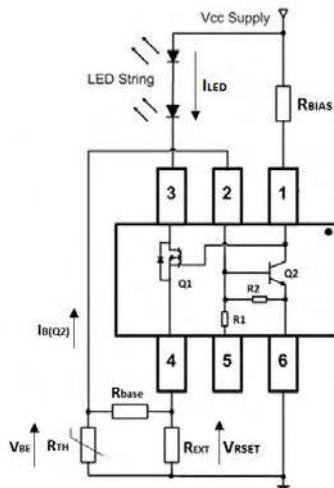

Figure 14 Constant LED Current Temperature Compensation for AL5801

The voltage drop V_{RSET} in the sense resistor R_{EXT} should be set to be 40 to 100mV higher than the $V_{BE(Q2)}$ at 25°C. Figure 11 shows the typical $V_{BE(Q2)}$ is 0.56V at room temperature with 0.1mA I_{BIAS} , so V_{RSET} is selected to be 0.62V.

With the V_{RSET} chosen, the sense resistor value for 350mA I_{LED} is determined by

$$R_{EXT} = V_{RSET} / I_{LED} = 0.62V / 350mA = 1.77\Omega$$

So a standard resistor value of 1.78Ω with 1% tolerance is used.

The R_{TH} resistance of the NTC thermistor at room temperature is recommended as 10kΩ. The value of base resistor R_{base} is set to be 470Ω. Q2's base current is obtained as

$$I_{B(Q2)} = (V_{RSET} - V_{BE(Q2)}) / R_{base} - V_{BE(Q2)} / R_{TH} = (0.62V - 0.56) / 470\Omega - 0.56V / 10k\Omega = 72\mu A$$

When $V_{BE(Q2)}$ is changed to V_{BE}^T as the temperature increases to $T^\circ C$, the thermistor resistance at $T^\circ C$ required to compensate this variation is given by

$$R_{TH}^T = V_{BE}^T / ((V_{RSET} - V_{BE}^T) / R_{base} - I_{B(Q2)})$$

At -2mV/°C, $V_{BE(Q2)}$ reduces to 0.44V from 0.56V as the temperature increases from +25°C to +85°C. From the above equation, the thermistor's resistance at +85°C to keep the same output current is given by

$$R_{TH}^{85} = 0.44V / ((0.62V - 0.44V) / 470\Omega - 72\mu A) = 1.4k\Omega$$

The NTC thermistor is chosen for compensation whose resistance is 10kΩ at +25°C and 1.38kΩ at +85°C with a β value of 3530.

Figure 15 shows the I_{LED} variation with temperature with and without temperature compensation.

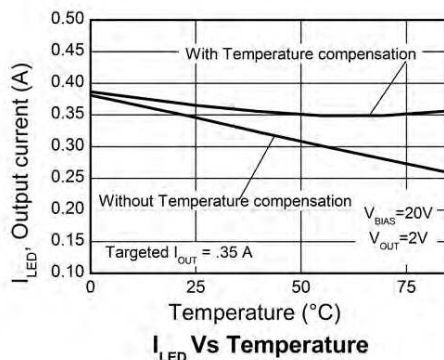

Figure 15 LED Current Variation with and without Temperature Compensation

PWM Dimming

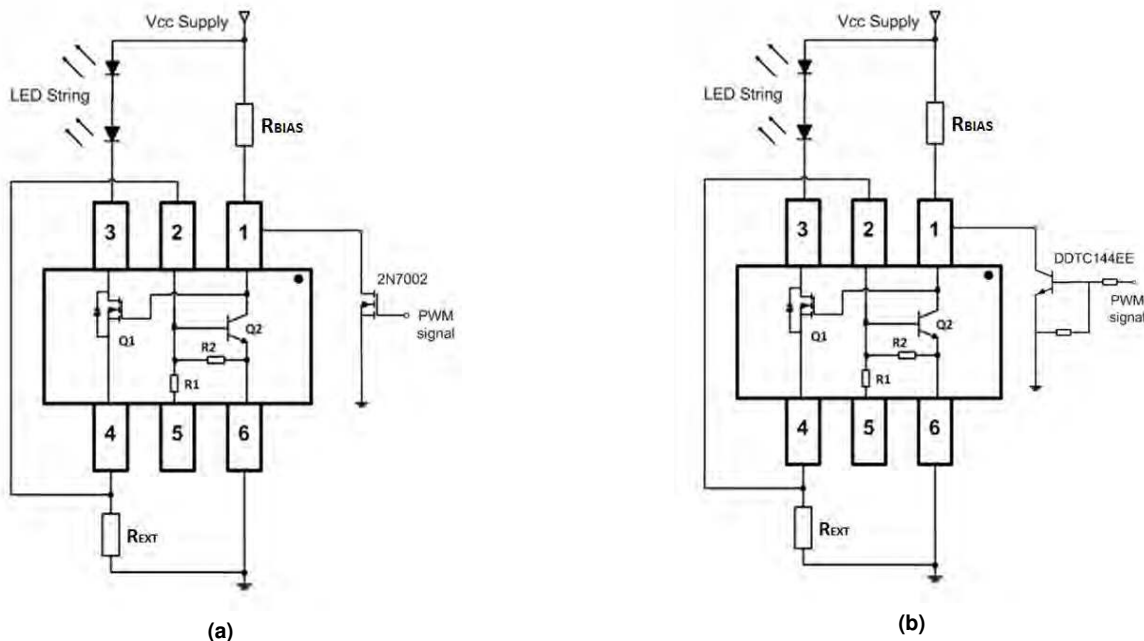

Figure 16 Application Circuits for LED Driver with PWM Dimming Functionality (a) MOSFET driving and (b) Transistor driving

PWM dimming can be achieved by driving the BIAS pin (1). An external open-collector NPN transistor or open-drain N-channel MOSFET can be used to drive the BIAS pin as shown in Figure 16. Dimming is achieved by turning the LEDs ON and OFF for a portion of a single cycle. The PWM signal can be provided by a micro-controller or by analog circuitry.

Figure 17 shows the LED current against the PWM signal duty ratio when the AL5801 is used to drive three series connected LEDs from a 12V supply. The PWM dimming frequency is set to 200Hz. The PWM signal is supplied to the open-Drain small signal MOSFET's gate as shown in Figure 16a. The BIAS pin signal is an inversion of the PWM drive to the MOSFET's gate. Therefore, a PWM signal duty cycle of 0% provides the maximum LED current. Sufficiently large PCB copper area is used for heat sinking of the AL5801 in order to minimize the device self-heating at +25°C ambient.

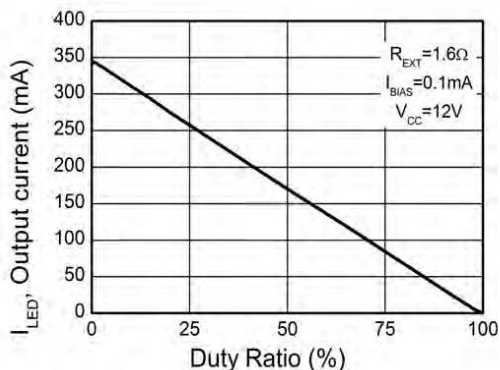

Figure 17 LED Current against PWM Dimming Signal Duty Ratio at 200Hz PWM Frequency

Ordering Information

Part Number	Qualification	Package Code	Packaging (Note 11)	7" Tape and Reel	
				Quantity	Part Number Suffix
AL5801W6-7	Commercial	W6	SOT26	3,000/Tape & Reel	-7
AL5801W6Q-7	Automotive	W6	SOT26	3,000/Tape & Reel	-7

Notes: 11. For packaging details, go to our website at <http://www.diodes.com>

Marking Information

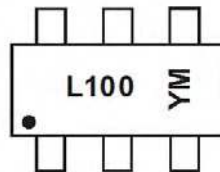

L100 = Product Type Marking Code
 YM = Date Code Marking
 Y = Year (ex: Y = 2012)
 M = Month (ex: 9 = September)

Date Code Key

Year	2012	2013	2014	2015	2016	2017	2018
Code	Z	A	B	C	D	E	F

Month	Jan	Feb	Mar	Apr	May	Jun	Jul	Aug	Sep	Oct	Nov	Dec
Code	1	2	3	4	5	6	7	8	9	O	N	D

Package Outline Dimensions (All dimensions in mm.)

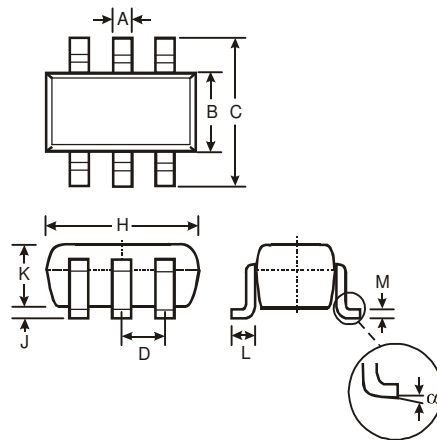

SOT26			
Dim	Min	Max	Typ
A	0.35	0.50	0.38
B	1.50	1.70	1.60
C	2.70	3.00	2.80
D	—	—	0.95
H	2.90	3.10	3.00
J	0.013	0.10	0.05
K	1.00	1.30	1.10
L	0.35	0.55	0.40
M	0.10	0.20	0.15
α	0°	8°	—

All Dimensions in mm

Suggested Pad Layout

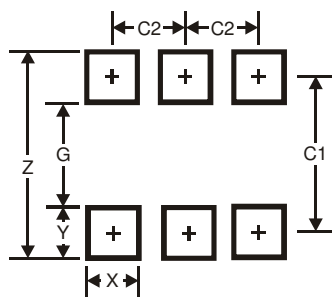

Dimensions	Value (in mm)
Z	3.20
G	1.60
X	0.55
Y	0.80
C1	2.40
C2	0.95

IMPORTANT NOTICE

DIODES INCORPORATED MAKES NO WARRANTY OF ANY KIND, EXPRESS OR IMPLIED, WITH REGARDS TO THIS DOCUMENT, INCLUDING, BUT NOT LIMITED TO, THE IMPLIED WARRANTIES OF MERCHANTABILITY AND FITNESS FOR A PARTICULAR PURPOSE (AND THEIR EQUIVALENTS UNDER THE LAWS OF ANY JURISDICTION).

Diodes Incorporated and its subsidiaries reserve the right to make modifications, enhancements, improvements, corrections or other changes without further notice to this document and any product described herein. Diodes Incorporated does not assume any liability arising out of the application or use of this document or any product described herein; neither does Diodes Incorporated convey any license under its patent or trademark rights, nor the rights of others. Any Customer or user of this document or products described herein in such applications shall assume all risks of such use and will agree to hold Diodes Incorporated and all the companies whose products are represented on Diodes Incorporated website, harmless against all damages.

Diodes Incorporated does not warrant or accept any liability whatsoever in respect of any products purchased through unauthorized sales channel. Should Customers purchase or use Diodes Incorporated products for any unintended or unauthorized application, Customers shall indemnify and hold Diodes Incorporated and its representatives harmless against all claims, damages, expenses, and attorney fees arising out of, directly or indirectly, any claim of personal injury or death associated with such unintended or unauthorized application.

Products described herein may be covered by one or more United States, international or foreign patents pending. Product names and markings noted herein may also be covered by one or more United States, international or foreign trademarks.

LIFE SUPPORT

Diodes Incorporated products are specifically not authorized for use as critical components in life support devices or systems without the express written approval of the Chief Executive Officer of Diodes Incorporated. As used herein:

A. Life support devices or systems are devices or systems which:

1. are intended to implant into the body, or
2. support or sustain life and whose failure to perform when properly used in accordance with instructions for use provided in the labeling can be reasonably expected to result in significant injury to the user.

B. A critical component is any component in a life support device or system whose failure to perform can be reasonably expected to cause the failure of the life support device or to affect its safety or effectiveness.

Customers represent that they have all necessary expertise in the safety and regulatory ramifications of their life support devices or systems, and acknowledge and agree that they are solely responsible for all legal, regulatory and safety-related requirements concerning their products and any use of Diodes Incorporated products in such safety-critical, life support devices or systems, notwithstanding any devices- or systems-related information or support that may be provided by Diodes Incorporated. Further, Customers must fully indemnify Diodes Incorporated and its representatives against any damages arising out of the use of Diodes Incorporated products in such safety-critical, life support devices or systems.

Copyright © 2012, Diodes Incorporated

www.diodes.com