

ADG811/ADG812/ADG813

FEATURES

- 0.5 Ω typ on resistance
- 0.8 Ω max on resistance at 125°C
- 1.65 V to 3.6 V operation
- Automotive temperature range: -40°C to +125°C
- High current carrying capability: 300 mA continuous
- Rail-to-rail switching operation
- Fast switching times: <25 ns
- Typical power consumption < 0.1 μ W

APPLICATIONS

- Cellular phones
- MP3 players
- Power routing
- Battery-powered systems
- PCMCIA cards
- Modems
- Audio and video signal routing
- Communications systems

GENERAL DESCRIPTION

The ADG811, ADG812, and ADG813 are low voltage CMOS devices containing four independently selectable switches. These switches offer ultralow on resistance of less than 0.8 Ω over the full temperature range. The digital inputs can handle 1.8 V logic with a 2.7 V to 3.6 V supply.

These devices contain four independent single-pole/single-throw (SPST) switches. The ADG811 and ADG812 differ only in that the digital control logic is inverted. The ADG811 switches are turned on with a logic low on the appropriate control input, while a logic high is required to turn on the switches of the ADG812. The ADG813 contains two switches whose digital control logic is similar to the ADG811, while the logic is inverted on the other two switches.

Each switch conducts equally well in both directions when on and has an input signal range that extends to the supplies. The ADG813 exhibits break-before-make switching action.

The ADG811, ADG812, and ADG813 are fully specified for 3.3 V, 2.5 V, and 1.8 V supply operation. They are available in a 16-lead TSSOP package.

Rev. A

Information furnished by Analog Devices is believed to be accurate and reliable. However, no responsibility is assumed by Analog Devices for its use, nor for any infringements of patents or other rights of third parties that may result from its use. Specifications subject to change without notice. No license is granted by implication or otherwise under any patent or patent rights of Analog Devices. Trademarks and registered trademarks are the property of their respective owners.

FUNCTIONAL BLOCK DIAGRAMS

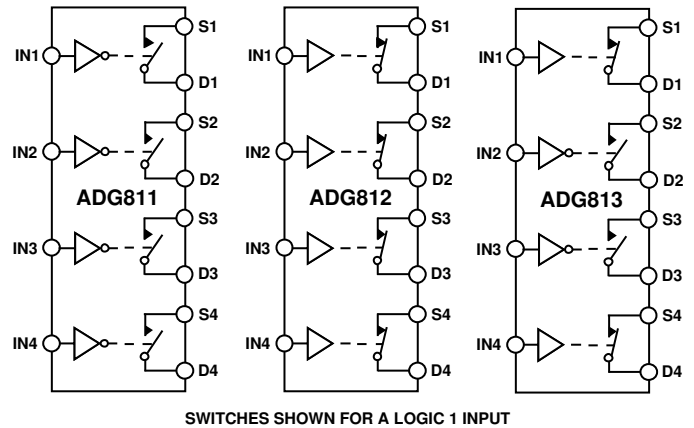

Figure 1.

PRODUCT HIGHLIGHTS

1. <0.8 Ω over full temperature range of -40°C to +125°C.
2. Single 1.65 V to 3.6 V operation.
3. Operational with 1.8 V CMOS logic.
4. High current handling capability (300 mA continuous current at 3.3 V).
5. Low THD+N (0.02% typ).

TABLE OF CONTENTS

| | | | |
|--|---|---|----|
| ADG811/ADG812/ADG813—Specifications | 3 | Typical Performance Characteristics | 8 |
| Absolute Maximum Ratings..... | 6 | Test Circuits..... | 11 |
| ESD Caution..... | 6 | Outline Dimensions | 13 |
| Pin Configuration and Function Descriptions..... | 7 | Ordering Guide | 13 |

REVISION HISTORY

5/04—Data Sheet Changed from Rev. 0 to Rev. A

Updated Format..... Universal
Updated Package Choices..... Universal

11/03—Revision 0: Initial Version

ADG811/ADG812/ADG813—SPECIFICATIONS

Table 1. $V_{DD} = 2.7\text{ V to }3.6\text{ V}$, $GND = 0\text{ V}$, unless otherwise noted¹

| Parameter | +25°C | -40°C to +85°C | -40°C to +125°C | Unit | Test Conditions/Comments |
|--|-----------|----------------|-----------------|-------------------|---|
| ANALOG SWITCH | | | | | |
| Analog Signal Range | | | 0 V to V_{DD} | V | |
| On Resistance (R_{ON}) | 0.5 | | | Ω typ | $V_{DD} = 2.7\text{ V}$, $V_S = 0\text{ V to }V_{DD}$, $I_S = 10\text{ mA}$; |
| | 0.65 | 0.75 | 0.8 | Ω max | Figure 18 |
| On Resistance Match between Channels (ΔR_{ON}) | 0.04 | | | Ω typ | $V_{DD} = 2.7\text{ V}$, $V_S = 0.5\text{ V}$, $I_S = 10\text{ mA}$ |
| | | 0.075 | 0.08 | Ω max | |
| On Resistance Flatness ($R_{FLAT(ON)}$) | 0.1 | | | Ω typ | $V_{DD} = 2.7\text{ V}$, $V_S = 0\text{ V to }V_{DD}$, $I_S = 10\text{ mA}$ |
| | | 0.15 | 0.16 | Ω max | |
| LEAKAGE CURRENTS | | | | | |
| Source Off Leakage I_S (OFF) | ± 0.2 | | | nA typ | $V_{DD} = 3.6\text{ V}$ |
| | ± 1 | ± 8 | ± 80 | nA max | $V_S = 0.6\text{ V}/3.3\text{ V}$, $V_D = 3.3\text{ V}/0.6\text{ V}$; |
| Drain Off Leakage I_D (OFF) | ± 0.2 | | | nA typ | Figure 19 |
| | ± 1 | ± 8 | ± 80 | nA max | $V_S = 0.6\text{ V}/3.3\text{ V}$, $V_D = 3.3\text{ V}/0.6\text{ V}$; |
| Channel On Leakage I_D, I_S (ON) | ± 0.2 | | | nA typ | Figure 19 |
| | ± 1 | ± 15 | ± 90 | nA max | $V_S = V_D = 0.6\text{ V or }3.3\text{ V}$; Figure 20 |
| DIGITAL INPUTS | | | | | |
| Input High Voltage, V_{INH} | | | 2 | V min | |
| Input Low Voltage, V_{INL} | | | 0.8 | V max | |
| Input Current, I_{INL} or I_{INH} | 0.005 | | | μA typ | $V_{IN} = V_{INL}$ or V_{INH} |
| | | | ± 0.1 | μA max | |
| C_{IN} , Digital Input Capacitance | 6 | | | pF typ | |
| DYNAMIC CHARACTERISTICS² | | | | | |
| t_{ON} | 21 | | | ns typ | $R_L = 50\ \Omega$, $C_L = 35\text{ pF}$ |
| | 25 | 26 | 28 | ns max | $V_S = 1.5\text{ V}/0\text{ V}$; Figure 21 |
| t_{OFF} | 4 | | | ns typ | $R_L = 50\ \Omega$, $C_L = 35\text{ pF}$ |
| | 5 | 6 | 7 | ns max | $V_S = 1.5\text{ V}$; Figure 21 |
| Break-Before-Make Time Delay (t_{BBM}) (ADG813 only) | 17 | | 5 | ns typ | $R_L = 50\ \Omega$, $C_L = 35\text{ pF}$ |
| | | | | ns min | $V_{S1} = V_{S2} = 1.5\text{ V}$; Figure 22 |
| Charge Injection | 30 | | | pC typ | $V_S = 1.5\text{ V}$, $R_S = 0\ \Omega$, $C_L = 1\text{ nF}$; |
| | | | | | Figure 23 |
| Off Isolation | -67 | | | dB typ | $R_L = 50\ \Omega$, $C_L = 5\text{ pF}$, $f = 100\text{ kHz}$; |
| | | | | | Figure 24 |
| Channel-to-Channel Crosstalk | -90 | | | dB typ | $R_L = 50\ \Omega$, $C_L = 5\text{ pF}$, $f = 100\text{ kHz}$; |
| | | | | | Figure 26 |
| Total Harmonic Distortion (THD + N) | 0.02 | | | % | $R_L = 32\ \Omega$, $f = 20\text{ Hz to }20\text{ kHz}$, |
| | | | | | $V_S = 2\text{ V p-p}$ |
| Insertion Loss | -0.05 | | | dB typ | $R_L = 50\ \Omega$, $C_L = 5\text{ pF}$, $f = 100\text{ kHz}$ |
| -3 dB Bandwidth | 90 | | | MHz typ | $R_L = 50\ \Omega$, $C_L = 5\text{ pF}$; Figure 25 |
| C_S (OFF) | 30 | | | pF typ | |
| C_D (OFF) | 35 | | | pF typ | |
| C_D, C_S (ON) | 60 | | | pF typ | |
| POWER REQUIREMENTS | | | | | |
| I_{DD} | 0.003 | | | μA typ | $V_{DD} = 3.6\text{ V}$ |
| | | 1.0 | 4 | μA max | Digital inputs = 0 V or 3.6 V |

¹Temperature range for the Y version is -40°C to $+125^\circ\text{C}$.²Guaranteed by design, not subject to production test.

ADG811/ADG812/ADG813

Table 2. $V_{DD} = 2.5 \text{ V} \pm 0.2 \text{ V}$, $GND = 0 \text{ V}$, unless otherwise noted¹

| Parameter | +25°C | -40°C to +85°C | -40°C to +125°C | Unit | Test Conditions/Comments |
|--|-----------|----------------|-----------------|-------------------|--|
| ANALOG SWITCH | | | | | |
| Analog Signal Range | | | 0 V to V_{DD} | V | |
| On Resistance (R_{ON}) | 0.65 | | | Ω typ | $V_{DD} = 2.3 \text{ V}$, $V_S = 0 \text{ V to } V_{DD}$, $I_S = 10 \text{ mA}$; |
| | 0.72 | 0.8 | 0.88 | Ω max | Figure 18 |
| On Resistance Match between Channels (ΔR_{ON}) | 0.04 | | | Ω typ | $V_{DD} = 2.3 \text{ V}$; $V_S = 0.55 \text{ V}$, $I_S = 10 \text{ mA}$ |
| | | 0.08 | 0.085 | Ω max | |
| On Resistance Flatness ($R_{FLAT(ON)}$) | 0.16 | | | Ω typ | $V_{DD} = 2.3 \text{ V}$; $V_S = 0 \text{ V to } V_{DD}$, $I_S = 10 \text{ mA}$ |
| | | 0.23 | 0.24 | Ω max | |
| LEAKAGE CURRENTS | | | | | |
| Source Off Leakage I_S (OFF) | ± 0.2 | | | nA typ | $V_{DD} = 2.7 \text{ V}$ |
| | ± 1 | ± 6 | ± 35 | nA max | $V_S = 0.6 \text{ V}/2.4 \text{ V}$, $V_D = 2.4 \text{ V}/0.6 \text{ V}$; |
| Drain Off Leakage I_D (OFF) | ± 0.2 | | | nA typ | $V_S = 0.6 \text{ V}/2.4 \text{ V}$, $V_D = 2.4 \text{ V}/0.6 \text{ V}$; |
| | ± 1 | ± 6 | ± 35 | nA max | Figure 19 |
| Channel On Leakage I_D, I_S (ON) | ± 0.2 | | | nA typ | $V_S = V_D = 0.6 \text{ V or } 2.4 \text{ V}$; Figure 20 |
| | ± 1 | ± 11 | ± 70 | nA max | |
| DIGITAL INPUTS | | | | | |
| Input High Voltage, V_{INH} | | | 1.7 | V min | |
| Input Low Voltage, V_{INL} | | | 0.7 | V max | |
| Input Current, I_{INL} or I_{INH} | 0.005 | | | μA typ | $V_{IN} = V_{INL}$ or V_{INH} |
| | | | ± 0.1 | μA max | |
| C_{IN} , Digital Input Capacitance | 6 | | | pF typ | |
| DYNAMIC CHARACTERISTICS² | | | | | |
| t_{ON} | 22 | | | ns typ | $R_L = 50 \Omega$, $C_L = 35 \text{ pF}$ |
| | 27 | 29 | 30 | ns max | $V_S = 1.5 \text{ V}/0 \text{ V}$; Figure 21 |
| t_{OFF} | 4 | | | ns typ | $R_L = 50 \Omega$, $C_L = 35 \text{ pF}$ |
| | 6 | 7 | 8 | ns max | $V_S = 1.5 \text{ V}$; Figure 21 |
| Break-Before-Make Time Delay (t_{BBM}) (ADG813 only) | 18 | | 5 | ns typ | $R_L = 50 \Omega$, $C_L = 35 \text{ pF}$ |
| | | | | ns min | $V_{S1} = V_{S2} = 1.5 \text{ V}$; Figure 22 |
| Charge Injection | 25 | | | pC typ | $V_S = 1.25 \text{ V}$, $R_S = 0 \Omega$, $C_L = 1 \text{ nF}$; |
| | | | | | Figure 23 |
| Off Isolation | -67 | | | dB typ | $R_L = 50 \Omega$, $C_L = 5 \text{ pF}$, $f = 100 \text{ kHz}$; |
| | | | | | Figure 24 |
| Channel-to-Channel Crosstalk | -90 | | | dB typ | $R_L = 50 \Omega$, $C_L = 5 \text{ pF}$, $f = 100 \text{ kHz}$; |
| | | | | | Figure 26 |
| Total Harmonic Distortion (THD + N) | 0.022 | | | % | $R_L = 32 \Omega$, $f = 20 \text{ Hz to } 20 \text{ kHz}$, $V_S = 1.5 \text{ V p-p}$ |
| Insertion Loss | -0.06 | | | dB typ | $R_L = 50 \Omega$, $C_L = 5 \text{ pF}$, $f = 100 \text{ kHz}$ |
| -3 dB Bandwidth | 90 | | | MHz typ | $R_L = 50 \Omega$, $C_L = 5 \text{ pF}$; Figure 25 |
| C_S (OFF) | 32 | | | pF typ | |
| C_D (OFF) | 37 | | | pF typ | |
| C_D, C_S (ON) | 60 | | | pF typ | |
| POWER REQUIREMENTS | | | | | |
| I_{DD} | 0.003 | | | μA typ | $V_{DD} = 2.7 \text{ V}$ |
| | | 1.0 | 4 | μA max | Digital inputs = 0 V or 2.7 V |

¹ Temperature range for the Y version is -40°C to +125°C.

² Guaranteed by design, not subject to production test.

Table 3. $V_{DD} = 1.65\text{ V to }1.95\text{ V}$, $GND = 0\text{ V}$, unless otherwise noted¹

| Parameter | +25°C | -40°C to +85°C | -40°C to +125°C | Unit | Test Conditions/Comments |
|---|-----------|----------------|-----------------|-------------------|--|
| ANALOG SWITCH | | | | | |
| Analog Signal Range | | | 0 V to V_{DD} | V | |
| On Resistance (R_{ON}) | 1 | | | Ω typ | $V_{DD} = 1.8\text{ V}$, $V_S = 0\text{ V to }V_{DD}$, $I_S = 10\text{ mA}$; Figure 18 |
| | 1.4 | 2.2 | 2.2 | Ω max | |
| | 2.5 | 4 | 4 | Ω max | $V_{DD} = 1.65\text{ V}$, $V_S = 0\text{ V to }V_{DD}$, $I_S = 10\text{ mA}$ |
| On Resistance Match between Channels (ΔR_{ON}) | 0.1 | | | Ω typ | $V_{DD} = 1.65\text{ V}$, $V_S = 0.7\text{ V}$, $I_S = 10\text{ mA}$ |
| LEAKAGE CURRENTS | | | | | |
| Source Off Leakage I_S (OFF) | ± 0.2 | | | nA typ | $V_{DD} = 1.95\text{ V}$ $V_S = 0.6\text{ V}/1.65\text{ V}$, $V_D = 1.65\text{ V}/0.6\text{ V}$; Figure 19 |
| | ± 1 | ± 5 | ± 30 | nA max | |
| Drain Off Leakage I_D (OFF) | ± 0.2 | | | nA typ | $V_S = 0.6\text{ V}/1.65\text{ V}$, $V_D = 1.65\text{ V}/0.6\text{ V}$; Figure 19 |
| | ± 1 | ± 5 | ± 30 | nA max | |
| Channel On Leakage I_D, I_S (ON) | ± 0.2 | | | nA typ | $V_S = V_D = 0.6\text{ V or }1.65\text{ V}$; Figure 20 |
| | ± 1 | ± 9 | ± 60 | nA max | |
| DIGITAL INPUTS | | | | | |
| Input High Voltage, V_{INH} | | | $0.65V_{DD}$ | V min | |
| Input Low Voltage, V_{INL} | | | $0.35V_{DD}$ | V max | |
| Input Current, I_{INL} or I_{INH} | 0.005 | | | μA typ | $V_{IN} = V_{INL}$ or V_{INH} |
| | | | ± 0.1 | μA max | |
| CIN, Digital Input Capacitance | 6 | | | pF typ | |
| DYNAMIC CHARACTERISTICS² | | | | | |
| t_{ON} | 27 | | | ns typ | $R_L = 50\ \Omega$, $C_L = 35\text{ pF}$ |
| | 35 | 36 | 37 | ns max | $V_S = 1.5\text{ V}/0\text{ V}$; Figure 21 |
| t_{OFF} | 6 | | | ns typ | $R_L = 50\ \Omega$, $C_L = 35\text{ pF}$ |
| | 8 | 9 | 10 | ns max | $V_S = 1.5\text{ V}$; Figure 21 |
| Break-Before-Make Time Delay (t_{BBM}) (ADG813 only) | 20 | | 5 | ns typ | $R_L = 50\ \Omega$, $C_L = 35\text{ pF}$ |
| | | | | ns min | $V_{S1} = V_{S2} = 1\text{ V}$; Figure 22 |
| Charge Injection | 15 | | | pC typ | $V_S = 1\text{ V}$, $R_S = 0\ \Omega$, $C_L = 1\text{ nF}$; Figure 23 |
| Off Isolation | -67 | | | dB typ | $R_L = 50\ \Omega$, $C_L = 5\text{ pF}$, $f = 100\text{ kHz}$; Figure 24 |
| Channel-to-Channel Crosstalk | -90 | | | dB typ | $R_L = 50\ \Omega$, $C_L = 5\text{ pF}$, $f = 100\text{ kHz}$; Figure 26 |
| Total Harmonic Distortion (THD + N) | 0.14 | | | % | $R_L = 32\ \Omega$, $f = 20\text{ Hz to }20\text{ kHz}$, $V_S = 1.2\text{ V p-p}$ |
| Insertion Loss | -0.08 | | | dB typ | $R_L = 50\ \Omega$, $C_L = 5\text{ pF}$, $f = 100\text{ kHz}$ |
| -3 dB Bandwidth | 90 | | | MHz typ | $R_L = 50\ \Omega$, $C_L = 5\text{ pF}$; Figure 25 |
| C_S (OFF) | 32 | | | pF typ | |
| C_D (OFF) | 38 | | | pF typ | |
| C_D, C_S (ON) | 60 | | | pF typ | |
| POWER REQUIREMENTS | | | | | |
| I_{DD} | 0.003 | | | μA typ | $V_{DD} = 1.95\text{ V}$ Digital inputs = 0 V or 1.95 V |
| | | 1.0 | 4 | μA max | |

¹Temperature range for the Y version is -40°C to +125°C.

²Guaranteed by design, not subject to production test.

ADG811/ADG812/ADG813

ABSOLUTE MAXIMUM RATINGS

Table 4. $T_A = 25^\circ\text{C}$, unless otherwise noted

| Parameter | Rating |
|---|---|
| V_{DD} to GND | -0.3 V to +4.6 V |
| Analog Inputs ¹ | -0.3 V to $V_{DD} + 0.3$ V |
| Digital Inputs ¹ | GND - 0.3 V to 4.6 V or 10 mA, whichever occurs first |
| Peak Current, S or D | (Pulsed at 1 ms, 10% Duty Cycle Max) |
| 3.3 V Operation | 500 mA |
| 2.5 V Operation | 460 mA |
| 1.8 V Operation | 420 mA |
| Continuous Current, S or D | |
| 3.3 V Operation | 300 mA |
| 2.5 V Operation | 275 mA |
| 1.8 V Operation | 250 mA |
| Operating Temperature Range Automotive (Y Version) | -40°C to +125°C |
| Storage Temperature Range | -65°C to +150°C |
| Junction Temperature | 150°C |
| TSSOP Package | |
| θ_{JA} Thermal Impedance | 150°C/W |
| θ_{JC} Thermal Impedance | 27°C/W |
| IR Reflow, Peak Temperature <20 sec | 235°C |

Stresses above those listed under Absolute Maximum Ratings may cause permanent damage to the device. This is a stress rating only; functional operation of the device at these or any other conditions above those listed in the operational sections of this specification is not implied. Exposure to absolute maximum rating conditions for extended periods may affect device reliability. Only one absolute maximum rating may be applied at any one time.

¹ Overvoltages at IN, S, or D are clamped by internal diodes. Current should be limited to the maximum ratings given.

ESD CAUTION

ESD (electrostatic discharge) sensitive device. Electrostatic charges as high as 4000 V readily accumulate on the human body and test equipment and can discharge without detection. Although this product features proprietary ESD protection circuitry, permanent damage may occur on devices subjected to high energy electrostatic discharges. Therefore, proper ESD precautions are recommended to avoid performance degradation or loss of functionality.



Table 5. ADG811/ADG812 Truth Table

| ADG811 IN | ADG812 IN | Switch Condition |
|-----------|-----------|------------------|
| 0 | 1 | On |
| 1 | 0 | Off |

Table 6. ADG813 Truth Table

| Logic | Switch 1, Switch 4 | Switch 2, Switch 3 |
|-------|--------------------|--------------------|
| 0 | Off | On |
| 1 | On | Off |

PIN CONFIGURATION AND FUNCTION DESCRIPTIONS

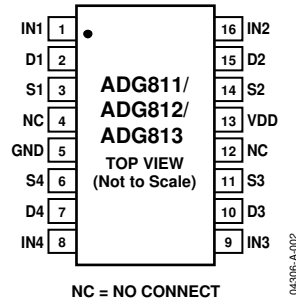

Figure 2.

Table 7. Terminology

| Term | Definition |
|--------------------------------------|--|
| V _{DD} | Most positive power supply potential. |
| I _{DD} | Positive supply current. |
| GND | Ground (0 V) reference. |
| S | Source terminal. May be an input or output. |
| D | Drain terminal. May be an input or output. |
| IN | Logic control input. |
| V _D , V _S | Analog voltage on Terminals D, S. |
| R _{ON} | Ohmic resistance between D and S. |
| R _{FLAT (ON)} | Flatness is defined as the difference between the maximum and minimum value of on resistance as measured over the specified analog signal range. |
| ΔR _{ON} | On resistance match between any two channels, i.e., R _{ON max} – R _{ON min} . |
| I _{S (OFF)} | Source leakage current with the switch off. |
| I _{D (OFF)} | Drain leakage current with the switch off. |
| I _D , I _{S (ON)} | Channel leakage current with the switch on. |
| V _{INL} | Maximum input voltage for Logic 0. |
| V _{INH} | Minimum input voltage for Logic 1. |
| I _{INL (I_{INH})} | Input current of the digital input. |
| C _{S (OFF)} | Off switch source capacitance. Measured with reference to ground. |
| C _{D (OFF)} | Off switch drain capacitance. Measured with reference to ground. |
| C _D , C _{S (ON)} | On switch capacitance. Measured with reference to ground. |
| C _{IN} | Digital input capacitance. |
| t _{ON} | Delay time between the 50% and the 90% points of the digital input and switch on condition. |
| t _{OFF} | Delay time between the 50% and the 90% points of the digital input and switch off condition. |
| t _{BBM} | On or off time measured between the 80% points of both switches, when switching from one to another. |
| Charge Injection | A measure of the glitch impulse transferred from the digital input to the analog output during on-to-off switching. |
| Off Isolation | A measure of unwanted signal coupling through an off switch. |
| Crosstalk | A measure of unwanted signal that is coupled through from one channel to another as a result of parasitic capacitance. |
| –3 dB Bandwidth | The frequency at which the output is attenuated by 3 dB. |
| On Response | The frequency response of the on switch. |
| Insertion Loss | The loss due to the on resistance of the switch. |
| THD + N | The ratio of the harmonic amplitudes plus noise of a signal to the fundamental. |

TYPICAL PERFORMANCE CHARACTERISTICS

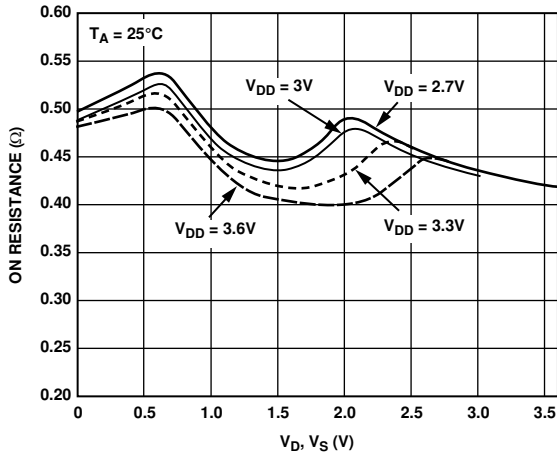

Figure 3. On Resistance vs. V_D (V_S), $V_{DD} = 2.7\text{ V to }3.6\text{ V}$

04306-A-003

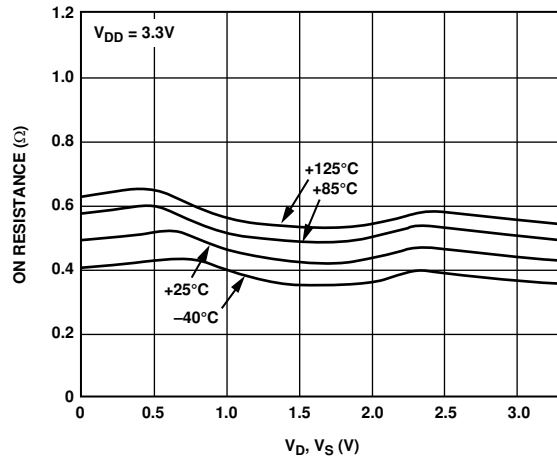

Figure 6. On Resistance vs. V_D (V_S) for Different Temperatures, $V_{DD} = 3.3\text{ V}$

04306-A-006

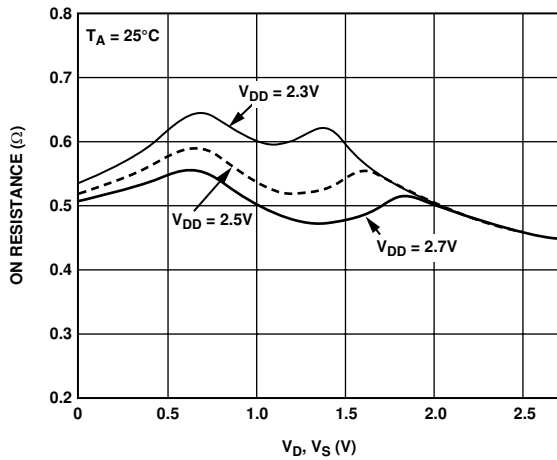

Figure 4. On Resistance vs. V_D (V_S), $V_{DD} = 2.5\text{ V} \pm 0.2\text{ V}$

04306-A-004

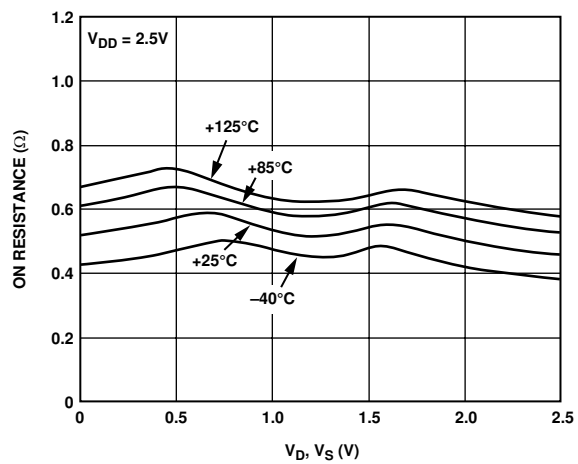

Figure 7. On Resistance vs. V_D (V_S) for Different Temperatures, $V_{DD} = 2.5\text{ V}$

04306-A-007

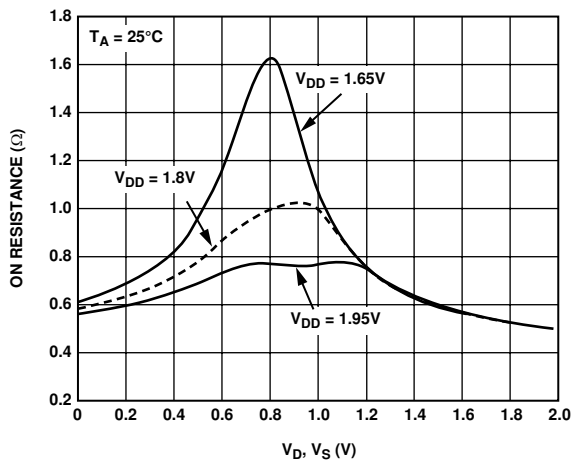

Figure 5. On Resistance vs. V_D (V_S), $V_{DD} = 1.8\text{ V} \pm 0.15\text{ V}$

04306-A-005

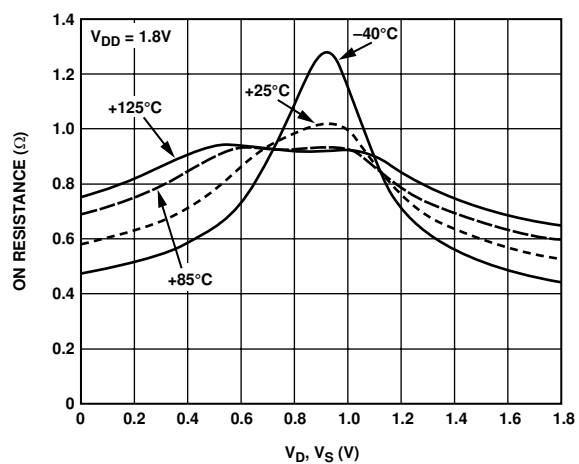

Figure 8. On Resistance vs. V_D (V_S) for Different Temperatures, $V_{DD} = 1.8\text{ V}$

04306-A-008

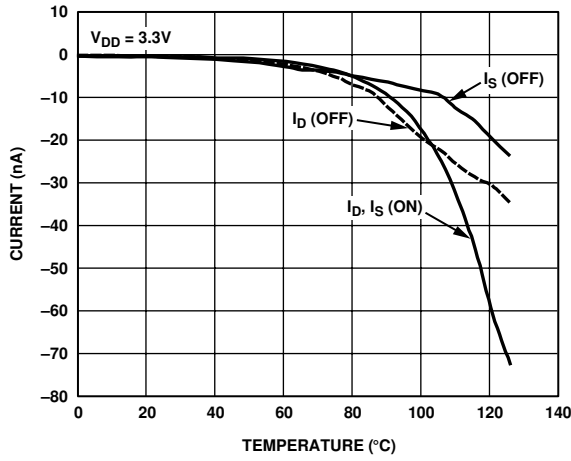

Figure 9. Leakage Currents vs. Temperature, $V_{DD} = 3.3\text{ V}$

04306-A-009

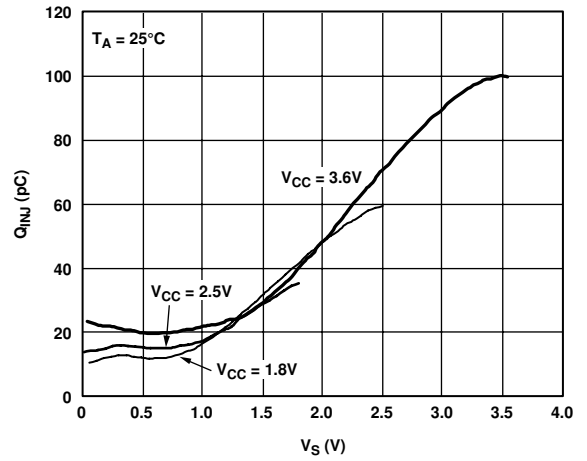

Figure 12. Charge Injection vs. Source Voltage

04306-A-012

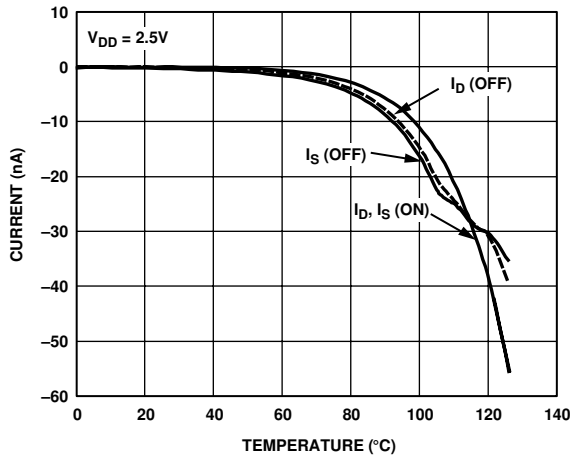

Figure 10. Leakage Currents vs. Temperature, $V_{DD} = 2.5\text{ V}$

04306-A-010

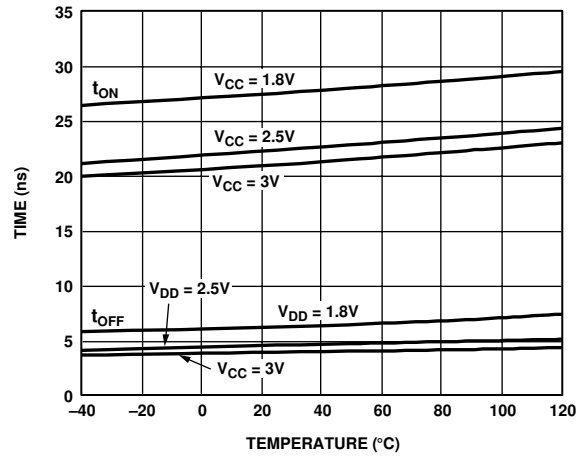

Figure 13. t_{ON}/t_{OFF} Times vs. Temperature

04306-A-013

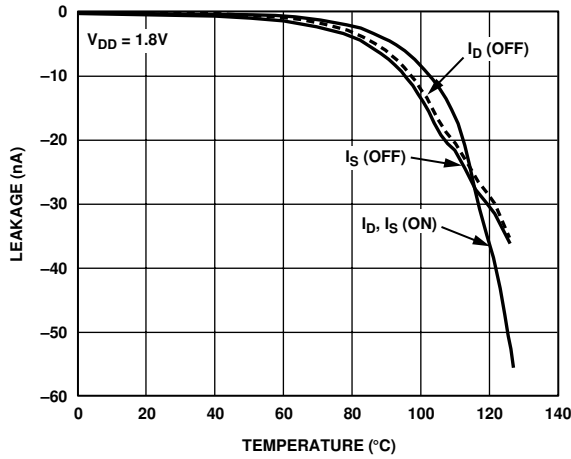

Figure 11. Leakage Currents vs. Temperature, $V_{DD} = 1.8\text{ V}$

04306-A-011

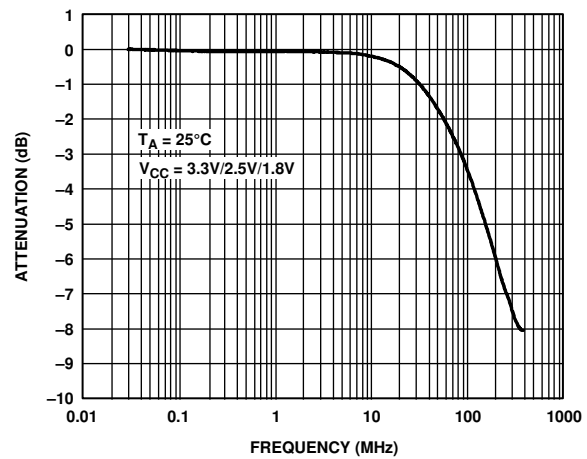

Figure 14. Bandwidth

04306-A-014

ADG811/ADG812/ADG813

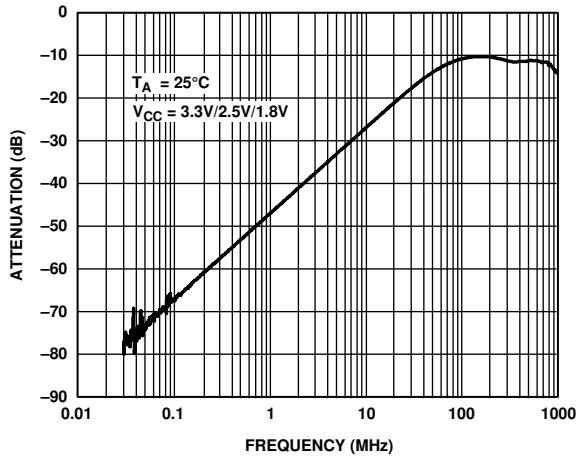

Figure 15. Crosstalk vs. Frequency

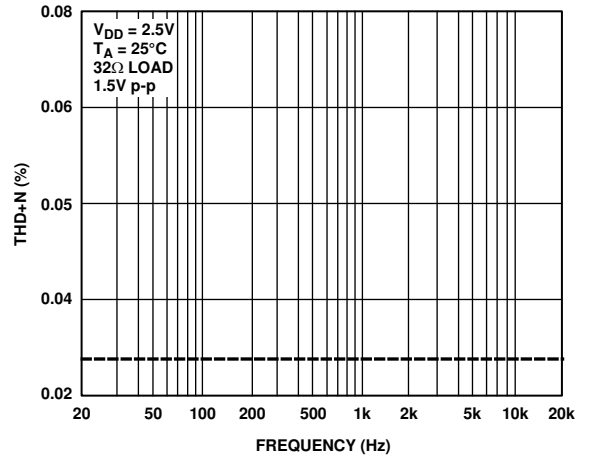

Figure 17. Total Harmonic Distortion

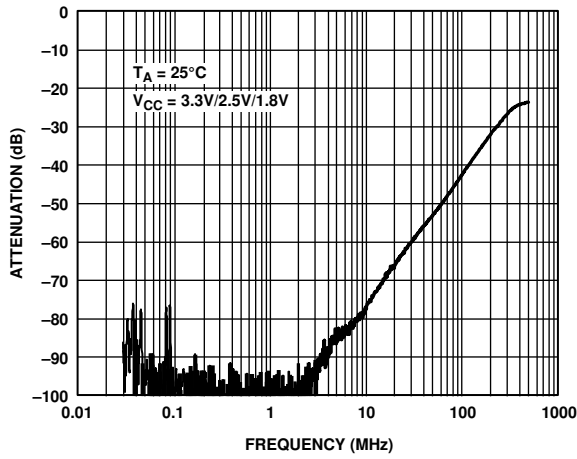

Figure 16. Off Isolation vs. Frequency

04306-A-015

04306-A-017

04306-A-016

TEST CIRCUITS

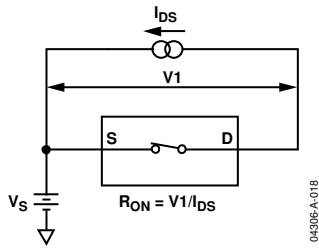

Figure 18. On Resistance

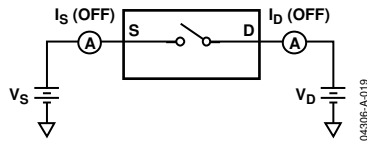

Figure 19. Off Leakage

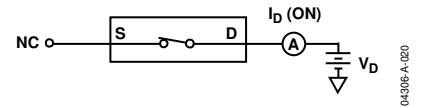

Figure 20. On Leakage

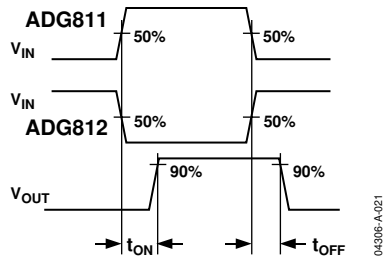
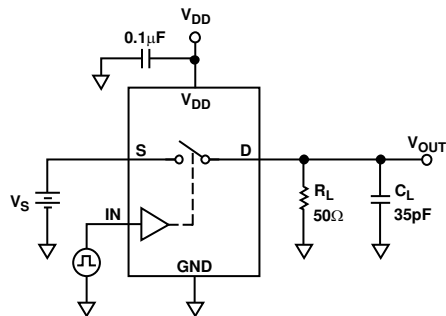

Figure 21. Switching Times

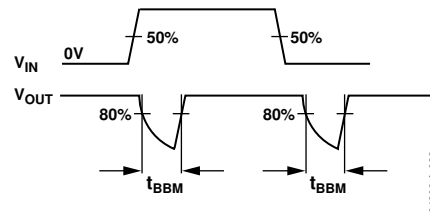
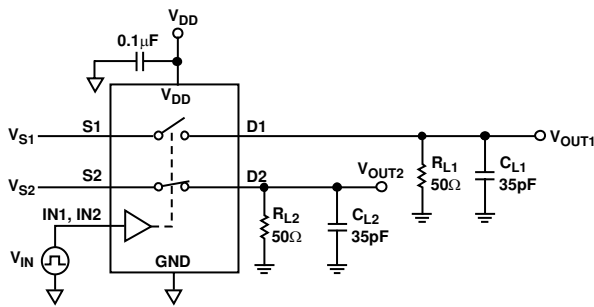

Figure 22. Break-Before-Make Time Delay, t_{BBM} (ADG813)

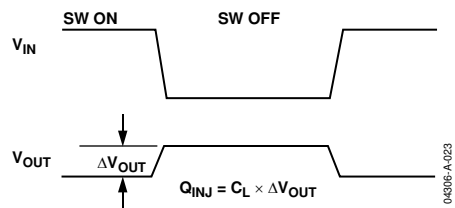
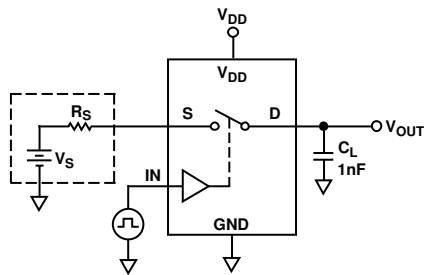
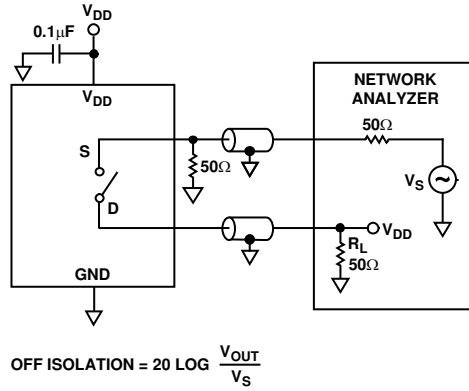
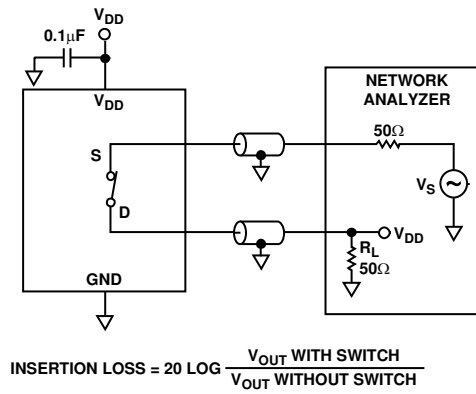

Figure 23. Charge Injection



04306-A-024

Figure 24. Off Isolation



04306-A-025

Figure 25. Bandwidth

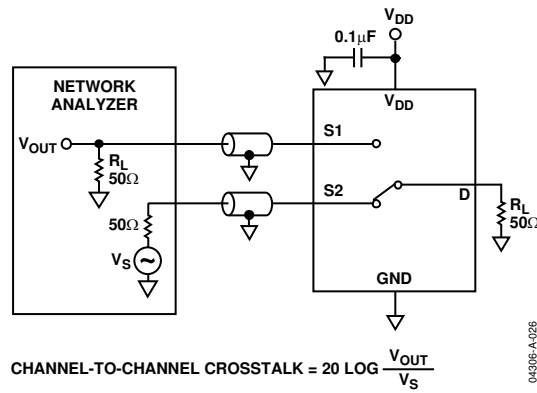

04306-A-026

Figure 26. Channel-to-Channel Crosstalk

OUTLINE DIMENSIONS

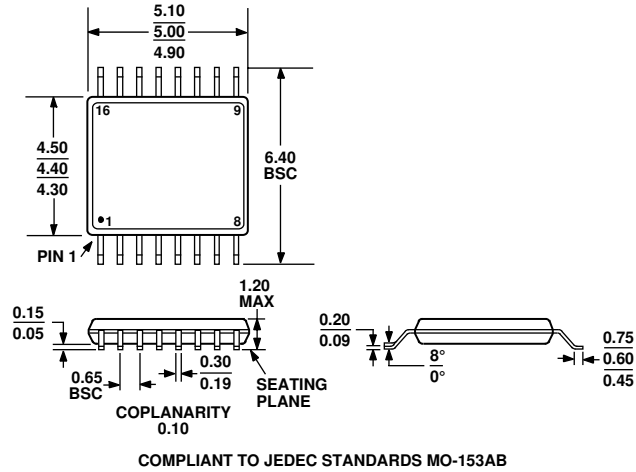

Figure 27. 16-Lead Thin Shrink Small Outline Package [TSSOP] (RU-16)
Dimensions shown in millimeters

ORDERING GUIDE

| Model | Temperature Range | Package Description | Package Option |
|-----------------|-------------------|-----------------------------------|----------------|
| ADG811YRU | -40°C to +125°C | Thin Shrink Small Outline (TSSOP) | RU-16 |
| ADG811YRU-REEL | -40°C to +125°C | Thin Shrink Small Outline (TSSOP) | RU-16 |
| ADG811YRU-REEL7 | -40°C to +125°C | Thin Shrink Small Outline (TSSOP) | RU-16 |
| AADG812YRU | -40°C to +125°C | Thin Shrink Small Outline (TSSOP) | RU-16 |
| ADG812YRU-REEL | -40°C to +125°C | Thin Shrink Small Outline (TSSOP) | RU-16 |
| ADG812YRU-REEL7 | -40°C to +125°C | Thin Shrink Small Outline (TSSOP) | RU-16 |
| ADG813YRU | -40°C to +125°C | Thin Shrink Small Outline (TSSOP) | RU-16 |
| ADG813YRU-REEL | -40°C to +125°C | Thin Shrink Small Outline (TSSOP) | RU-16 |
| ADG813YRU-REEL7 | -40°C to +125°C | Thin Shrink Small Outline (TSSOP) | RU-16 |

NOTES

NOTES

NOTES