

Ratings

Voltage: 150 V
Temperature: -40~70 °C

Conductor

Conductor count: 6
Gauge: 30 AWG 0.05 mm²
Material: Tinned copper strands
Strand size: $\phi 0.05 \times 25$
Resistance at 20 °C: 385 Ω /km Max

Insulator

Material: HDPE
Color: black, white, red, yellow, blue, green
Diameter: $\phi 0.65 \pm 0.10$ mm
Nominal thickness: 0.18 mm
Resistance at 20 °C: 100 M Ω /km Min

Wrap

Material: cotton paper

Filler

Material: aramid fiber

Outer jacket

Material: TPU
Color: gray
Diameter: $\phi 3.2 \pm 0.20$ mm
Nominal thickness: 0.50 mm

Tests

Tensile strength: 15 kgf min
Dielectric test: 1500 V dc for 1 minute without breakdown
Bend test at 200 g, $\pm 60^\circ$, 30 cycles /min: 15,000 cycle minimum

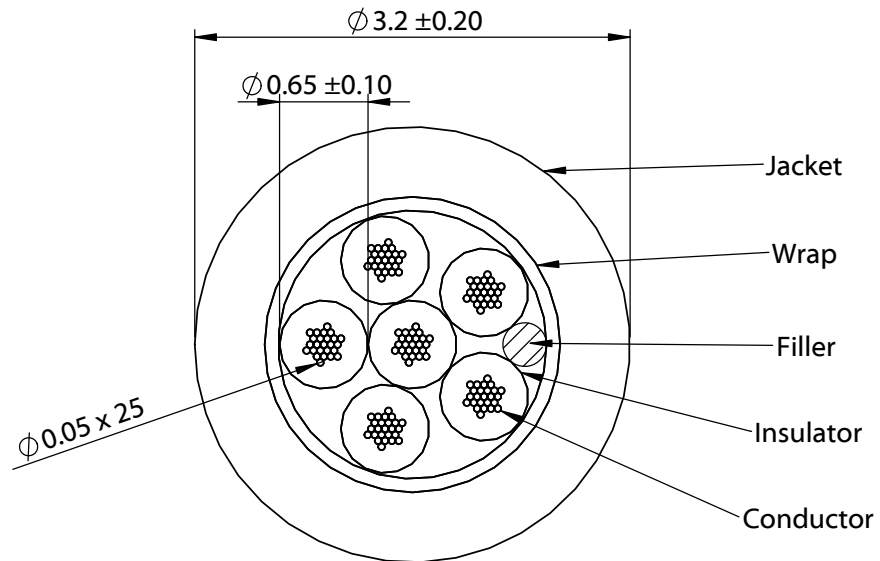
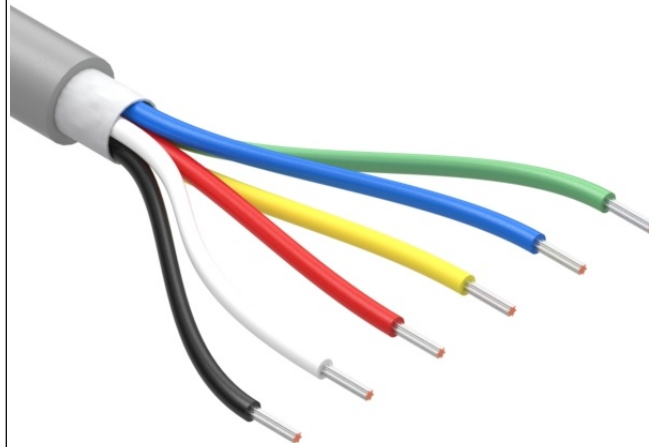

Revision:	Date:	Description:
A	9/9/2022	Initial release

Prepared: **PB**
Digitally signed by PB
Date: 2022.09.12
12:31:05 -07'00'

Verified: **MP**
Digitally signed by MP
Date: 2022.09.20
09:38:25 -07'00'

Dimensions are in millimeters.
Tolerances:
X: ± 0.5 mm
X.X: ± 0.3 mm
X.XX: ± 0.05 mm

Notes:

RoHS compliant
Jacket meets ISO 10993 Biological Compatibility
Phthalate and halogen free
Function test: no open, no short, no intermittent

Description:
Wire, 6C TS, 30 AWG, 150V, 70C, 3.2 mm, TPU, 75A, gray, WBL

TENSILITY

tel 1.541.323.3228 800 877.670.7118
fax 1.541.323.4202 web tensility.com

Size: A Part number: 30-02740

Scale: 18:1 Sheet 1 of 1