

NOTES:

1. IMPEDANCE : 75 OHM
2. FERQUENCY RANGE : DC - 6 GHz
3. VSWR : 1.1 MAX.
4. DIELECTRIC WITHSTANDING VOLTAGE : 1500 VRMS.MIN.
5. CRIMPED FERRULE
HEX CRIMP SIZE .178"
6. CRIMPED CONTACT PIN
HEX CRIMP SIZE 0.041" OR 0.042"

112955-11		REVISIONS			
DRAWING NO.	REV	DESCRIPTION	DATE	ECO	APPR
THIRD ANGLE PROJ.	NC	INITIAL RELEASE	19-Sep-11	XXXXXX	--
	A	ADD BeCu RETAINER RING	27-Apr-12	2297	--
	B	MODIFY OUTER CONTACT TO IMPROVE PERFORMANCE	09-Aug-12	2355	AAP
	C	ADD GEPCO CABLE CALLOUT. CORRECT B.O.M.	25-Sep-12	2377	RV
	D	ADD CONTACT PIN CRIMP OPTION	25-Apr-13	2468	MB
	E	FREQUENCY DC-6 GHz WAS DC-3 GHz	1/22/16	50654	CL

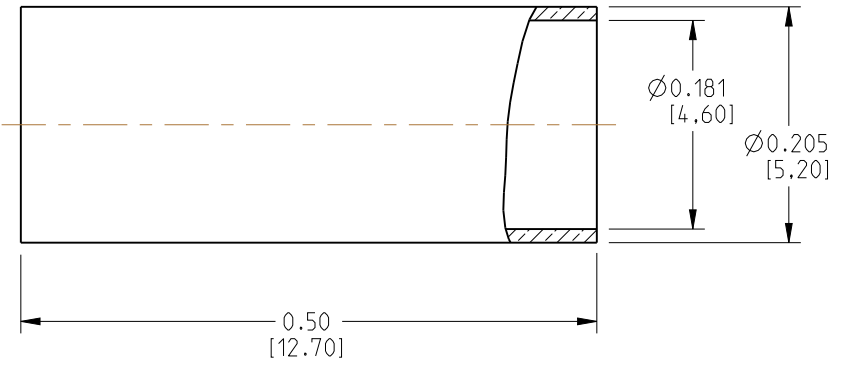
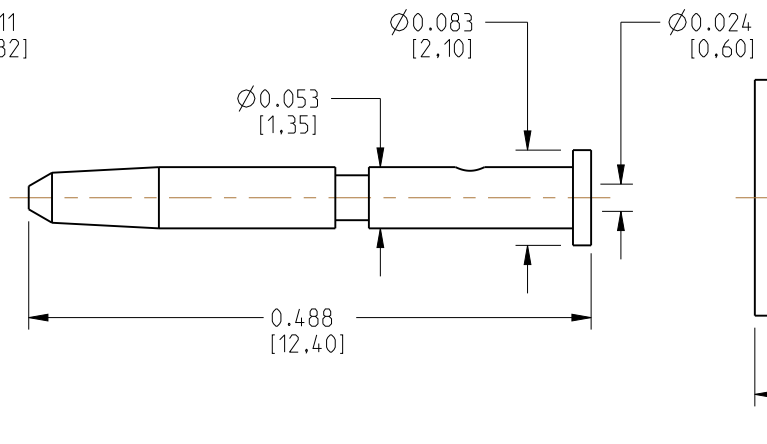
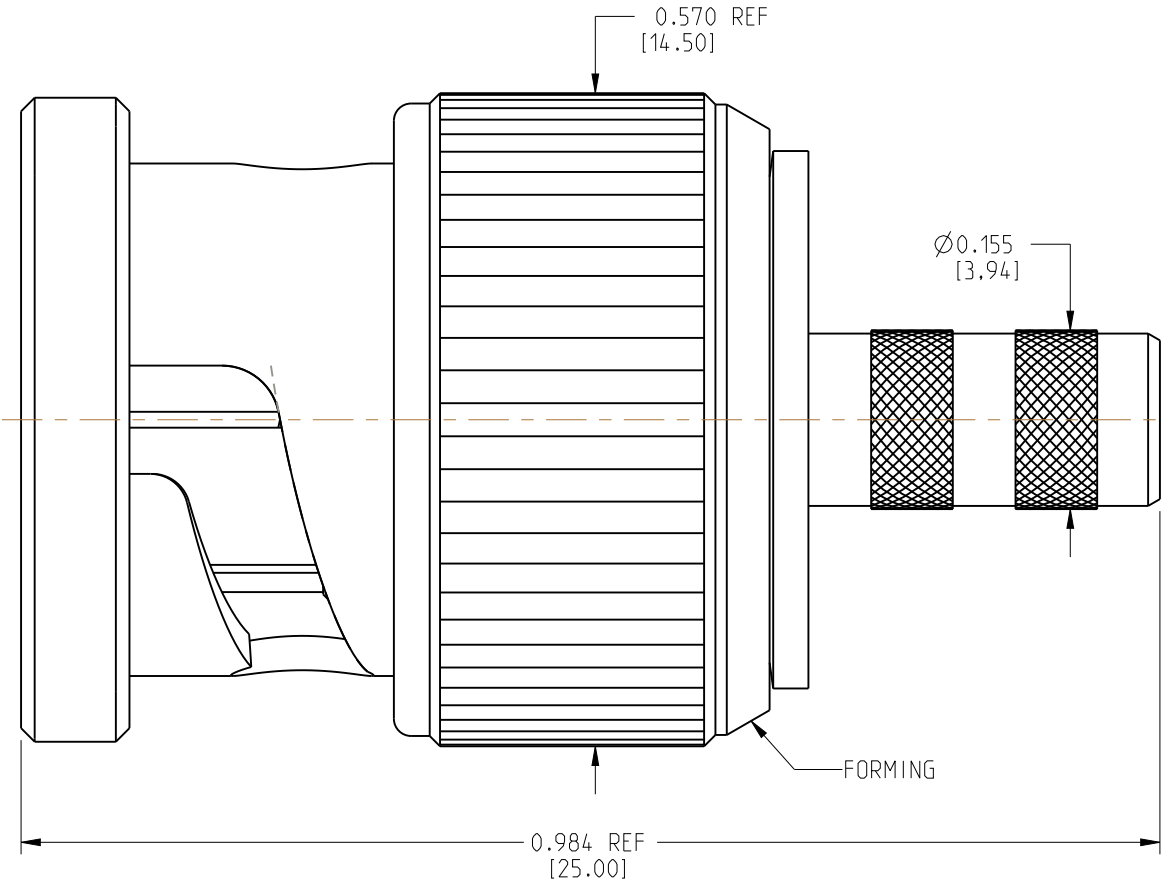
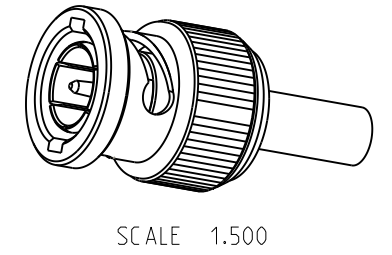
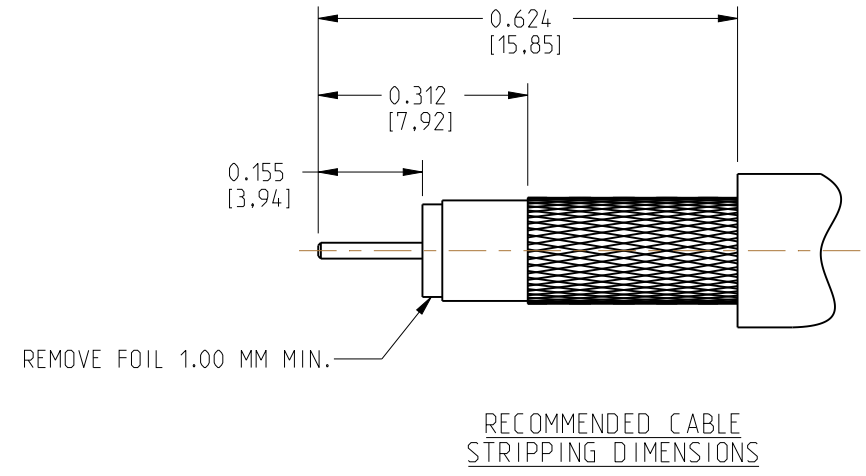

10	FERRULE	BRASS	NICKEL	1
9	CONTACT PIN	BRASS	GOLD	1
8	RING	BRASS	NICKEL	1
7	WASHER	BRASS	NICKEL	1
6	SPRING	SK5	NICKEL	1
5	GASKET	RUBBER	RED	1
4	OUTER CONTACT	BERYLLIUM COPPER	NICKEL	1
3	INSULATOR	PTFE	NATURAL	1
2	BODY	BRASS	NICKEL	1
1	SHELL	BRASS	NICKEL	1
NO	DESCRIPTION	MATERIAL	FINISH	QTY

UNLESS OTHERWISE SPECIFIED, DIMENSIONS ARE IN INCHES AND TOLERANCES ARE: 2 PLACE DECIMAL ±.015 (0,381 mm) 3 PLACE DECIMAL ±.005 (0,127 mm) ANGLES ± 1°	MATERIAL SEE BOM TABLE	DRAWN NISCHIT MV	DATE 25-Apr-13	TITLE BNC CRIMP PLUG - 75 OHM FOR BELDEN 1855A AND GEPCO VDM230 CABLE	Amphenol Connex
	REFERENCE	ENGINEER NISCHIT MV	DATE 25-Apr-13		
NOTICE - These drawings, specifications, or other data (1) are, and remain the property of Amphenol Corp. (2) must be returned upon request; and (3) are confidential and not to be disclosed to any person other than those to whom they are given by Amphenol Corp. The furnishing of these drawings, specifications, or other data by Amphenol Corp., or to any other person to anyone for any purpose is not to be regarded by implication or otherwise in any manner licensing, granting rights or permitting such holder or any other person to manufacture, use or sell any product, process or design, patented or otherwise, that may in any way be related to or disclosed by said drawings, specifications, or other data.		APPROVED	DATE	DWG SIZE B	DRAWING NO. 112955-11
					SHEET 1 OF 1