

# 3M™ Water Filtration Products

SPEC# \_\_\_\_\_

QUANTITY \_\_\_\_\_

application: **Retro-fit Water Filtration Cartridges**

model:

## 9000 Series Cartridges



The 3M™ Water Filtration Products line of 9000 Series cartridges are an economical way to provide the benefits of 3M Water Filtration Products in select competitive systems without incurring additional capital expense. A choice of medias such as graded density carbon with micron ratings from 0.5 to 5, as well as optional integrated scale inhibition provide solutions for varying water conditions. The 9000 Series cartridges do not require activation for functionality, allowing an operator to change the cartridge in seconds.

### PRODUCT BENEFITS

- Fits in select competitive systems.
- No pre-activation required.
- Sanitary Quick Change (SQC) encapsulated cartridges reduce contamination during change-outs.
- FDA CFR-21 and/or NSF compliant materials.

### PRODUCT SPECIFICATIONS

Model Number	Part Number	Micron Rating	Chlorine Reduction, Hardness Capacity	Claims	Flow Rate
CFS9110	55721-01	5	N/A	Particulate Reduction	1.5 gpm (5.7 lpm)
CFS9112	55892-03	1	10,000 gal. (37,854 lit.)	Particulate, Chlorine Taste & Odor Reduction	
CFS9812X	56012-01	0.5	9,000 gal. (34,069 lit.)	Particulate, Chlorine Taste & Odor and Cyst Reduction	
CFS9720	55890-03	5	4,800 gal. (18,170 lit.)	Particulate, Chlorine Taste & Odor Reduction	
CFS9110-S	55721-03	5	N/A	Particulate Reduction and Scale Inhibition	
CFS9112-S	55892-01	1	10,000 gal. (37,854 lit.)	Particulate, Chlorine Taste & Odor Reduction and Scale Inhibition	
CFS9812X-S	56012-03	0.5	9,000 gal. (34,069 lit.)	Particulate, Chlorine Taste & Odor, Cyst Reduction and Scale Inhibition	
CFS9720-S	55890-01	5	4,800 gal. (18,170 lit.)	Particulate, Chlorine Taste & Odor Reduction and Scale Inhibition	
CFS9710	55891-03	5	2,400 gal. (9,085 lit.)	Particulate, Chlorine Taste & Odor Reduction	
CFS9710-S	55891-01	5	2,400 gal. (9,085 lit.)	Particulate, Chlorine Taste & Odor Reduction and Scale Inhibition	1 gpm (3.8 lpm)
CFS9005-IMF	55937-01	N/A	N/A	Scale Inhibition	2 gpm (7.6 lpm)
CFS9112EL	55892-13	1	12,600 gal. (47,696 lit.)	Particulate, Chlorine Taste & Odor Reduction	1.67 gpm (6.3 lpm)
CFS9812ELX	56012-05	0.5	14,000 gal. (52,996 lit.)	Particulate, Chlorine Taste & Odor and Cyst Reduction	
CFS9720EL	55890-05	5	5,500 gal. (20,820 lit.)	Particulate, Chlorine Taste & Odor Reduction	
CFS9112EL-CL	56012-35	1	3,600 gal. (13,626 lit.)	Particulate, Chlorine Taste & Odor & Chloramines Reduction	
CFS9112EL-S	55892-15	1	12,600 gal. (47,696 lit.)	Particulate, Chlorine Taste & Odor Reduction and Scale Inhibition	
CFS9812ELX-S	56012-07	0.5	14,000 gal. (52,996 lit.)	Particulate, Chlorine Taste & Odor, Cyst Reduction and Scale Inhibition	0.5 gpm (1.9 lpm)
CFS9720EL-S	55890-07	5	5,500 gal. (20,820 lit.)	Particulate, Chlorine Taste & Odor Reduction and Scale Inhibition	
SWC9135	55722-01	N/A	1,350 Grains	Scale Reduction	
SWC9135-C	55722-03	N/A	1,100 Grains	Particulate, Chlorine Taste & Odor and Scale Reduction	



# 9000 Series Replacements

# 3M™ Water Filtration Products

SPEC# \_\_\_\_\_  
 QUANTITY \_\_\_\_\_  
 MODEL NUMBER \_\_\_\_\_  
 PART NUMBER \_\_\_\_\_

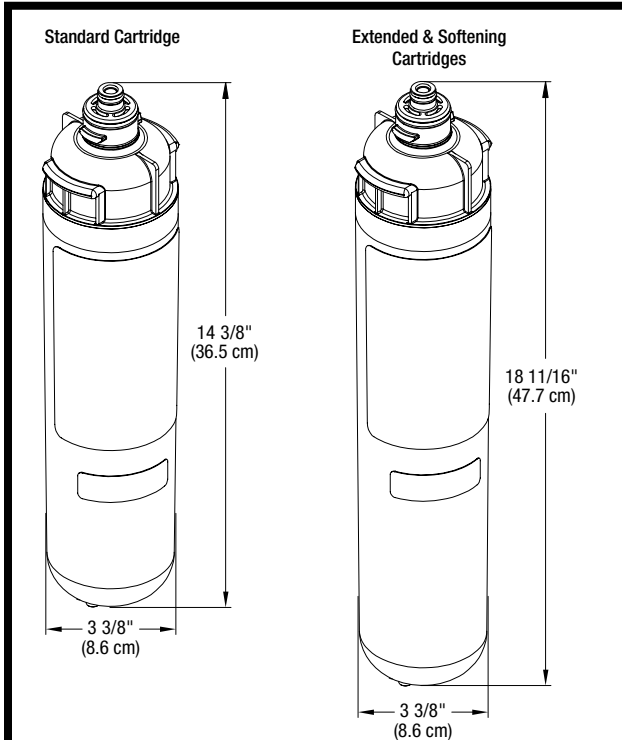

**⚠ WARNING: To reduce the risk associated with the ingestion of contaminants:**

- Do not use with water that is microbiologically unsafe or of unknown quality without adequate disinfection before or after the system. Systems certified for cyst reduction may be used on disinfected water that may contain filterable cysts. EPA Establishment #070595-CT-001

3M Purification Inc. recommends regularly scheduled maintenance and replacement of the filter cartridge(s) in order for the product to perform as advertised/sold. 3M Purification Inc. shall not be liable for system failures due to improper maintenance.

## SPECIFICATIONS

- System maximum operating pressure of 125 psi (862 kPa) and operating temperatures of 100°F (37.8°C).
- System materials are FDA CFR-21 and/or NSF compliant.
- Filter cartridges require no pre-activation.

## LIMITED WARRANTY

3M Purification Inc. warrants these Products will be free from defects in material and manufacture for one (1) year from the date of purchase. This warranty does not cover failures resulting from abuse, misuse, alteration or damage not caused by 3M Purification Inc. or failure to follow installation and use instructions. No warranty is given as to the service life of any filter cartridge or membrane as it will vary with local water conditions and water consumption. **3M PURIFICATION INC. MAKES NO OTHER WARRANTIES OR CONDITIONS, EXPRESS OR IMPLIED, INCLUDING, BUT NOT LIMITED TO, ANY IMPLIED WARRANTY OR CONDITION OF MERCHANTABILITY OR FITNESS FOR A PARTICULAR PURPOSE OR ANY IMPLIED WARRANTY OR CONDITION ARISING OUT OF A COURSE OF DEALING, CUSTOMER OR USAGE OF TRADE.** If the Product fails to satisfy this Limited Warranty during the warranty period, 3M Purification Inc. will replace the Product or refund your Product purchase price. This warranty does not cover labor. **The remedy stated in this paragraph is Customer's sole remedy and 3M Purification Inc's exclusive obligation. For additional information, see the entire Limited Warranty located in the System Installation and Operating Instruction Manual.**

**Limitation of Liability:** 3M Purification Inc. will not be liable for any loss or damage arising from the use of the Product(s), whether direct, indirect, special, incidental, or consequential, regardless of the legal theory asserted, including warranty, contract, negligence or strict liability. Some states do not allow the exclusion or limitation of incidental or consequential damages, so the above limitation may not apply to you.

## CROSS REFERENCE GUIDE

	Model #	Part #	Replaces	Flow Rate
Standard	CFS9110	55721-01	CV	1.5 gpm (5.7 lpm)
	CFS9112	55892-03	MC <sup>2</sup>	
	CFS9812X	56012-01	MC <sup>2</sup>	
	CFS9720	55890-03	MC <sup>2</sup> /2CB5/4CB5	
	CFS9110-S	55721-03	MH <sup>2</sup> /I-2000	
	CFS9112-S	55892-01	MH <sup>2</sup> /I-2000	
	CFS9812X-S	56012-03	MH <sup>2</sup> /I-2000/BH <sup>2</sup>	
	CFS9720-S	55890-01	MC <sup>2</sup> /2CB5-S/4CB5-S	
	CFS9710	55891-03	2CB5	1 gpm (3.8 lpm)
	CFS9710-S	55891-01	BH <sup>2</sup>	1 gpm (3.8 lpm)
CFS9005-IMF	55937-01	IMF	N/A	

	Model #	Part #	Replaces	Flow Rate
Extended	CFS9110EL	55721-05	XCV	1.67 gpm (6.3 lpm)
	CFS9112EL	55892-13	MC <sup>2</sup> /XC <sup>2</sup> /7CB5	
	CFS9812ELX	56012-05	MC <sup>2</sup> /XC <sup>2</sup>	
	CFS9720EL	55890-05	4CB5/7CB5	
	CFS9110EL-S	55721-07	MH <sup>2</sup> /I-4000	
	CFS9112EL-CL	56012-35	7CLM	
	CFS9112EL-S	55892-15	MH <sup>2</sup> /I-4000	
	CFS9812ELX-S	56012-07	MH <sup>2</sup> /I-4000	
	CFS9720EL-S	55890-01	4CB5-S/7CB5-S/I-4000	0.5 gpm (1.9 lpm)
	SWC9135	55722-01	7S0	
SWC9135-C	55722-03	7S0		

## IMPORTANT: INSTALLATION TIPS

These installation tips are for informational purposes only and are not intended to be used as actual installation instructions. **CAUTION: To reduce the risk associated with property damage due to water leakage:**

- **Read and follow** Use Instructions before installation and use of this system.
- Installation and use **MUST** comply with all state and local plumbing codes.
- **Protect from freezing**, remove filter cartridge when temperatures are expected to drop below 40°F (4.4°C).
- **Do not install on hot water supply lines.** The maximum operating water temperature of this filter system is 100°F (37.8°C).
- **Do not install** if water pressure exceeds 125 psi (862 kPa). If your water pressure exceeds 80 psi (552 kPa), you must install a pressure limiting valve. Contact a plumbing professional if you are uncertain how to check your water pressure.
- **Do not install** where water hammer conditions may occur. If water hammer conditions exist you must install a water hammer arrester. Contact a plumbing professional if you are uncertain how to check for this condition.
- The disposable filter cartridge **MUST** be replaced every 12 months, at the rated capacity or if a noticeable reduction in flow rate occurs.



3M Purification Inc.  
 400 Research Parkway  
 Meriden, CT 06450 U.S.A.  
 Toll Free: 1-866-990-9785  
 Worldwide: 203-237-5541  
 Fax: 203-238-8701  
 www.3Mpurification.com  
 www.3Mfoodservice.com

3M is a trademark of 3M Company.  
 NSF is a trademark of NSF International.  
 © 2013 3M Company. All rights reserved.  
 70020193820 REV 0413



Visit [www.nsf.org](http://www.nsf.org) for the claims associated with products that are NSF listed.