

REVISIONS			
REV	DESCRIPTION, ECN, EAR NO.	DATE	APP'D
A	PROPOSAL	APR17/18	L.CHAN

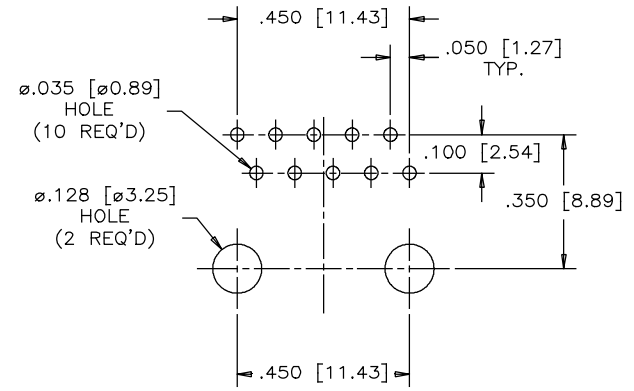
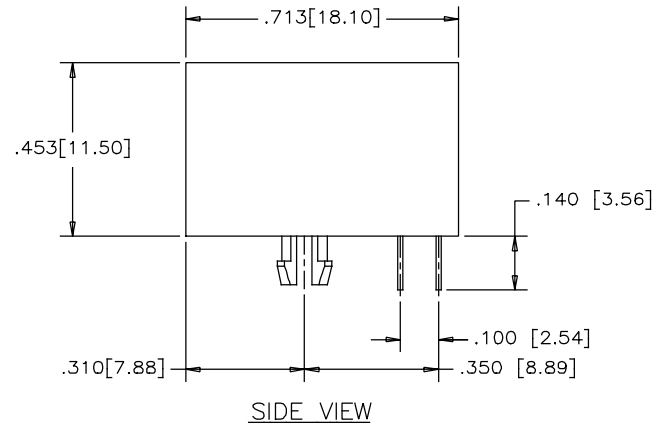
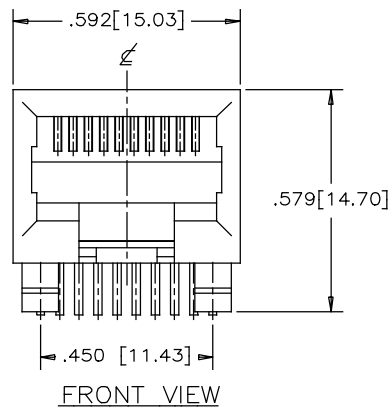

**MATERIALS:**  
 PLASTIC HOUSING: HIGH TEMPERATURE THERMOPLASTIC  
 FLAMMABILITY RATING UL94V-0.  
 COLOUR, BLACK.

**CONTACTS:** PHOSPHOR BRONZE  
 PLATING: SELECTIVE GOLD PLATING ON MATING SURFACES  
 SEE AMPHENOL PART NUMBER FOR DETAIL.  
 50 μ" [1.27 MICRONS]  
 MIN. NICKEL UNDERPLATE.  
 100 μ" [2.54 MICRONS]  
 MIN. MATTE-TIN OR GOLD FLASH  
 ON CONTACT TAILS.

AMPHENOL PART NUMBER: RJE05-1AA-0X10-H

GOLD PLATING  
 1 = 6 μINCH  
 2 = 15 μINCH  
 3 = 30 μINCH  
 4 = 50 μINCH

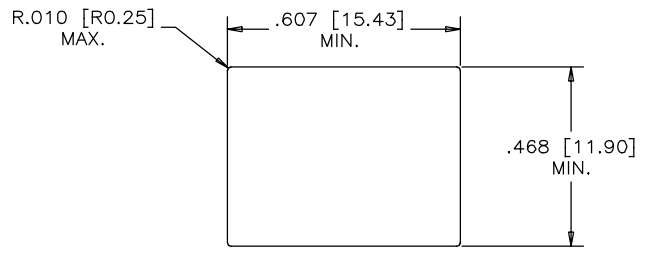

UNLESS SPECIFIED OTHERWISE	DRAWN HANSON.C	APR17/18
PRIMARY UNITS INCHES	CHECKED L.CHAN	APR17/18
SECONDARY MILLIMETERS	M.E. APP'D	
REFERENCE IN PARENTHESES	Q.A. APP'D	
	DWG APP'D	
	ENG. REL. NO.	
1 DECIMAL PLACE	REF.	
2 DECIMAL PLACES ±0.020		
3 DECIMAL PLACES ±0.015		
ANGULAR DEGREES ±1.5'		
	THIRD ANGLE PROJECTION	DO NOT SCALE DRAWING

Amphenol Canada Corp. www.amphenolcanada.com	
RJE05 SERIES MODULAR JACK, 10 POSITION, 10 CONTACTS, UNSHIELDED - RoHS COMPLIANT	
DWG NO. P-RJE05-1AA-0X10-H	REV A
CODE ID NO. 03554	DWG SIZE SCALE SHEET 1 OF 1