

## LOW DROPOUT VOLTAGE REGULATOR

### ■ GENERAL DESCRIPTION

The NJM2836 is a 500mA output low dropout voltage regulator.

Advanced Bipolar technology achieves low noise, high ripple rejection and high supply voltage.

2.1V to 15.5V output voltage range, 2.2 $\mu$ F small decoupling capacitor, built-in noise bypass capacitor make the NJM2836 suitable for various applications.

### ■ PACKAGE OUTLINE

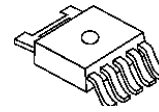

NJM2836DL3

### ■ FEATURES

- Output voltage options available                    2.1 ~ 15.5V
- High Ripple Rejection                                    75dB typ. (f=1kHz,Vo=3V Version)
- Low Output Noise Voltage                              Vno=45 $\mu$ Vrms typ.
- Output Current    Io(max.)=500mA
- High Precision Output Voltage                        Vo $\pm$ 1.0%
- Output capacitor with 2.2 $\mu$ F ceramic capacitor (Vo $\geq$ 5.1V)
- Low Dropout Voltage                                    0.18V typ. (Io=300mA)
- ON/OFF Control
- Internal Thermal Overload Protection
- Internal Over Current Protection
- Bipolar Technology
- Package Outline    TO-252-5

### ■ PIN CONFIGURATION

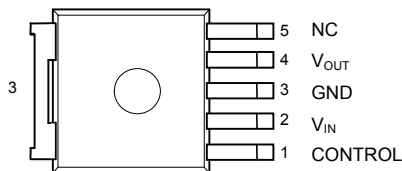

NJM2836DL3

### ■ BLOCK DIAGRAM

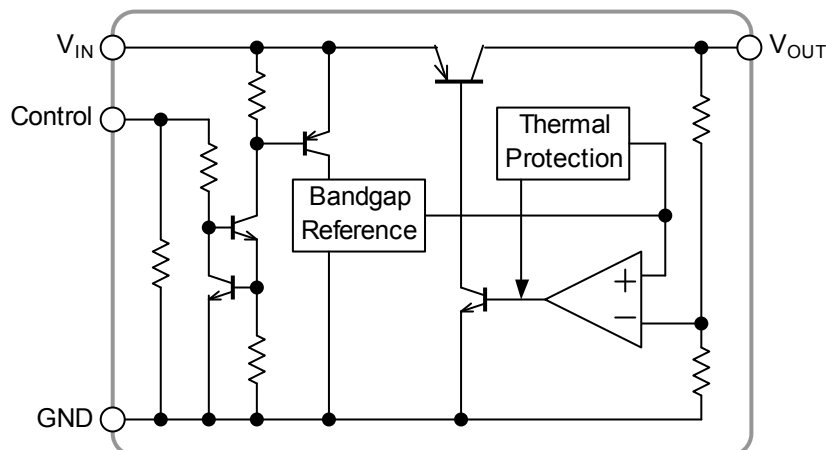

■ OUTPUT VOLTAGE RANK LIST

The WHITE column shows applicable Voltage Rank(s)

Device Name	Vout	Device Name	Vout	Device Name	Vout
NJM2836DL3-21	2.1V	NJM2836DL3-36	3.6V	NJM2836DL3-08	8.0V
NJM2836DL3-22	2.2V	NJM2836DL3-37	3.7V	NJM2836DL3-85	8.5V
NJM2836DL3-23	2.3V	NJM2836DL3-38	3.8V	NJM2836DL3-09	9.0V
NJM2836DL3-24	2.4V	NJM2836DL3-39	3.9V	NJM2836DL3-10	10.0V
NJM2836DL3-25	2.5V	NJM2836DL3-04	4.0V	NJM2836DL3-12	12.0V
NJM2836DL3-26	2.6V	NJM2836DL3-41	4.1V	NJM2836DL3-125	12.5V
NJM2836DL3-27	2.7V	NJM2836DL3-42	4.2V	NJM2836DL3-13	13.0V
NJM2836DL3-28	2.8V	NJM2836DL3-43	4.3V	NJM2836DL3-15	15.0V
NJM2836DL3-29	2.9V	NJM2836DL3-44	4.4V		
NJM2836DL3-03	3.0V	NJM2836DL3-45	4.5V		
NJM2836DL3-31	3.1V	NJM2836DL3-46	4.6V		
NJM2836DL3-32	3.2V	NJM2836DL3-47	4.7V		
NJM2836DL3-33	3.3V	NJM2836DL3-48	4.8V		
NJM2836DL3-34	3.4V	NJM2836DL3-49	4.9V		
NJM2836DL3-35	3.5V	NJM2836DL3-05	5.0V		

## ■ ABSOLUTE MAXIMUM RATINGS (Ta=25°C)

PARAMETER	SYMBOL	RATINGS	UNIT
Input Voltage	V <sub>IN</sub>	+20	V
Control Voltage	V <sub>CONT</sub>	+20	V
Power Dissipation	P <sub>D</sub>	1190(*1) 3125(*2)	mW
Operating Temperature	Topr	-40 ~ +85	°C
Storage Temperature	Tstg	-40 ~ +150	°C

(\*1): Mounted on glass epoxy board. (76.2 × 114.3 × 1.6mm:based on EIA/JDEC standard size, 2Layers, Cu area 100mm<sup>2</sup>)

(\*2): Mounted on glass epoxy board. (76.2 × 114.3 × 1.6mm:based on EIA/JDEC standard, 4Layers)

(For 4Layers: Applying 74.2 × 74.2mm inner Cu area and a thermal via hole to a board based on JEDEC standard JESD51-5)

## ■ ELECTRICAL CHARACTERISTICS

(V<sub>IN</sub>=Vo+1V, C<sub>IN</sub>=0.33μF, Co=2.2μF (2.9V<Vo≤5V:Co=4.7μF,Vo≤2.9V:Co=10μF), Ta=25°C)

PARAMETER	SYMBOL	TEST CONDITION	MIN	TYP	MAX	UNIT	
Output Voltage	Vo	Io=30mA	-1.0%	-	+1.0%	V	
Quiescent Current	I <sub>Q</sub>	Io=0mA	Vo≤5V Version	-	200	300	μA
			5V<Vo≤10V Version	-	215	315	μA
			10V<Vo≤15V Version	-	230	330	μA
Quiescent Current at Control OFF	I <sub>Q(OFF)</sub>	V <sub>CONT</sub> =0V	-	-	100	nA	
Output Current	Io	Vo-0.3V	500	650	-	mA	
Line Regulation	ΔVo/ΔV <sub>IN</sub>	V <sub>IN</sub> =Vo+1V ~ Vo+6V (Vo≤12V), V <sub>IN</sub> =Vo+1V ~ 18V (Vo>12V), Io=30mA	-	-	0.10	%/V	
Load Regulation	ΔVo/ΔIo	Io=0 ~ 500mA	-	-	0.007	%/mA	
Dropout Voltage(*3)	ΔV <sub>I-O</sub>	Io=300mA	-	0.18	0.28	V	
Ripple Rejection	RR	ein=200mVrms, f=1kHz, Io=10mA Vo=3V Version	-	75	-	dB	
Average Temperature Coefficient of Output Voltage	ΔVo/ΔTa	Ta=0 ~ 85°C, Io=10mA	-	± 50	-	ppm/°C	
Output Noise Voltage	V <sub>NO</sub>	f=10Hz ~ 80kHz, Io=10mA, Vo=3V Version	-	45	-	μVrms	
Control Current	I <sub>CONT</sub>	V <sub>CONT</sub> =1.6V	-	3	12	μA	
Control Voltage for ON-state	V <sub>CONT(ON)</sub>		1.6	-	-	V	
Control Voltage for OFF-state	V <sub>CONT(OFF)</sub>		-	-	0.6	V	
Input Voltage	V <sub>IN</sub>		-	-	18	V	

(\*3): The above specification is a common specification for all output voltages.

Therefore, it may be different from the individual specification for a specific output voltage.

■ THERMAL CHARACTERISTICS

PARAMETER	SYMBOL	VALUE	UNIT
Junction-to-ambient thermal resistance	$\theta_{ja}$	105 (*3) 40 (*4)	°C/W
Junction-to-Top of package characterization parameter	$\psi_{jt}$	17 (*3) 12 (*4)	°C/W

(\*4): Mounted on glass epoxy board. (76.2 × 114.3 × 1.6mm:based on EIA/JDEC standard size, 2Layers, Cu area 100mm<sup>2</sup>)

(\*5): Mounted on glass epoxy board. (76.2 × 114.3 × 1.6mm:based on EIA/JDEC standard, 4Layers)

(For 4Layers: Applying 74.2 × 74.2mm inner Cu area and a thermal via hole to a board based on JEDEC standard JESD51-5)

■ POWER DISSIPATION vs. AMBIENT TEMPERATURE

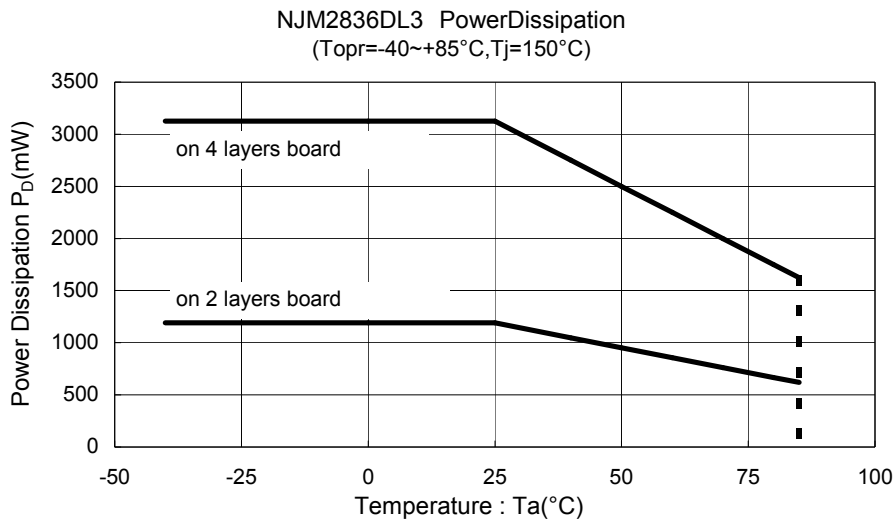

■ TEST CIRCUIT

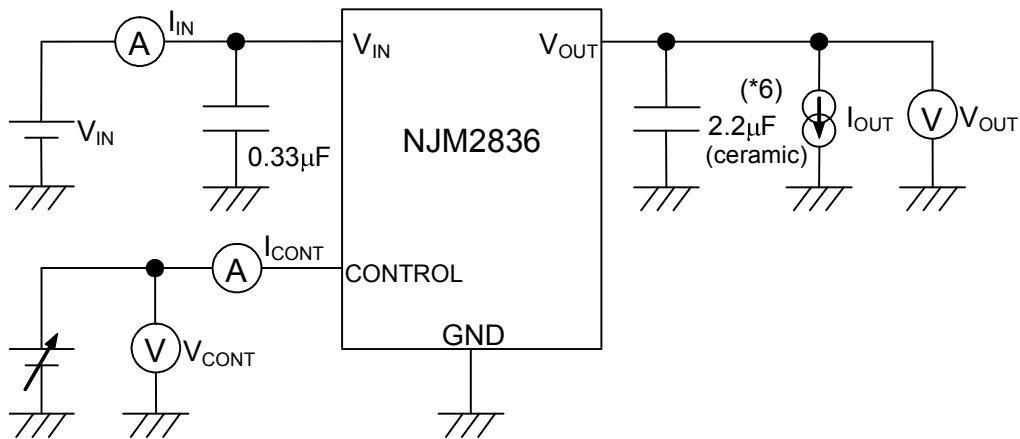

(\*6) 2.9V < V<sub>o</sub> ≤ 5V version : C<sub>o</sub> = 4.7µF (ceramic)

V<sub>o</sub> ≤ 2.9V version : C<sub>o</sub> = 10µF (ceramic)

■ TYPICAL APPLICATIONS

① In the case where ON/OFF Control is not required

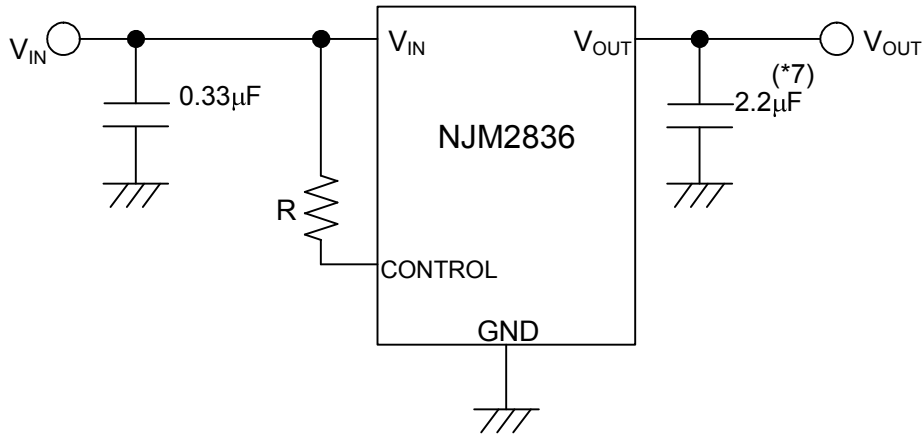

(\*7): 2.9V <  $V_o$  ≤ 5V version :  $C_o = 4.7\mu\text{F}$   
 $V_o \leq 2.9\text{V}$  version :  $C_o = 10\mu\text{F}$

Connect control pin to  $V_{IN}$  pin

② In use of ON/OFF CONTROL

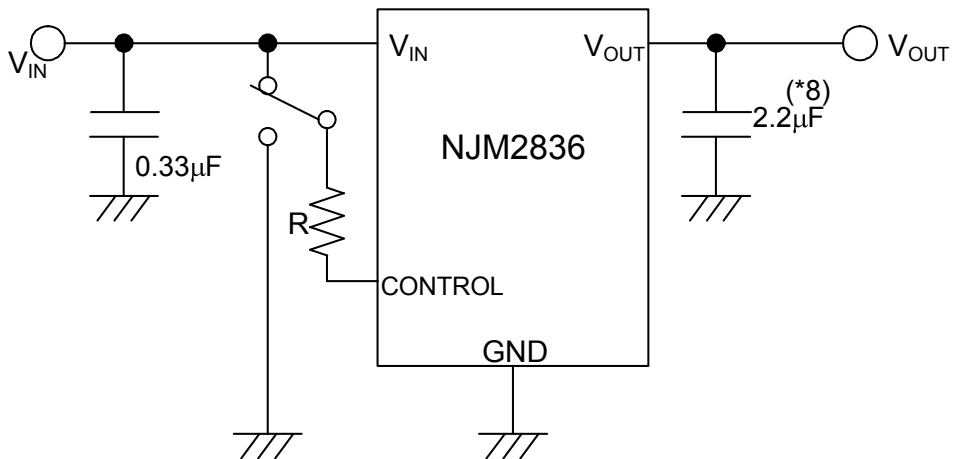

(\*8) : 2.9V <  $V_o$  ≤ 5V version :  $C_o = 4.7\mu\text{F}$   
 $V_o \leq 2.9\text{V}$  version :  $C_o = 10\mu\text{F}$

State of control pin:

- “H” → output is enabled.
- “L” or “open” → output is disabled.

\*In the case of using a resistor "R" between  $V_{IN}$  and control.

If this resistor is inserted, the control current could be reduced when the control voltage is high.

The applied voltage to control pin should set to consider voltage drop through the resistor "R" and the minimum control voltage for ON-state.

The  $V_{CONT(ON)}$  and  $I_{CONT}$  have temperature dependence as shown in the "Control Current vs. Temperature" and "Control Voltage vs. Temperature" characteristics. Therefore, the resistor "R" should be selected to consider the temperature characteristics.

\*Input Capacitor  $C_{IN}$

Input Capacitor  $C_{IN}$  is required to prevent oscillation and reduce power supply ripple for applications when high power supply impedance or a long power supply line.

Therefore, use the recommended  $C_{IN}$  value (refer to conditions of ELECTRIC CHARACTERISTIC) or larger and should connect between GND and  $V_{IN}$  as shortest path as possible to avoid the problem.

\*Output Capacitor  $C_O$

Output capacitor ( $C_O$ ) will be required for a phase compensation of the internal error amplifier.

The capacitance and the equivalent series resistance (ESR) influence to stable operation of the regulator.

Use of a smaller  $C_O$  may cause excess output noise or oscillation of the regulator due to lack of the phase compensation.

On the other hand, Use of a larger  $C_O$  reduces output noise and ripple output, and also improves output transient response when rapid load change.

Therefore, use the recommended  $C_O$  value (refer to conditions of ELECTRIC CHARACTERISTIC) or larger and should connect between GND and  $V_{OUT}$  as shortest path as possible for stable operation

The recommended capacitance depends on the output voltage rank. Especially, low voltage regulator requires larger  $C_O$  value.

In addition, you should consider varied characteristics of capacitor (a frequency characteristic, a temperature characteristic, a DC bias characteristic and so on) and unevenness peculiar to a capacitor supplier enough.

When selecting  $C_O$ , recommend that have withstand voltage margin against output voltage and superior temperature characteristic though this product is designed stability works with wide range ESR of capacitor including low ESR products.

## TYPICAL CHARACTERISTICS

NJM2836\_15V  
Output Voltage vs Input Voltage

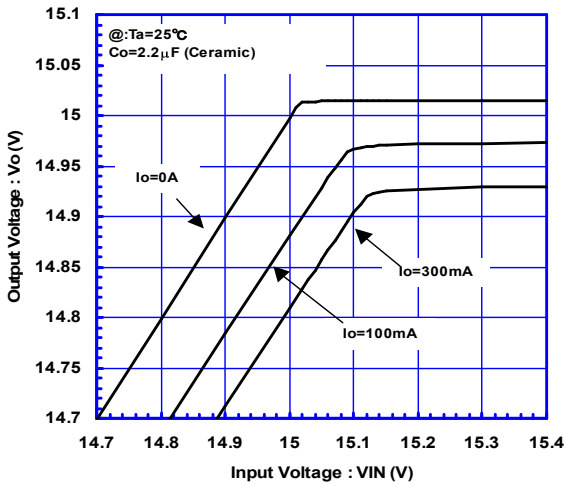

NJM2836\_15V  
Over Current Protection vs Output Current

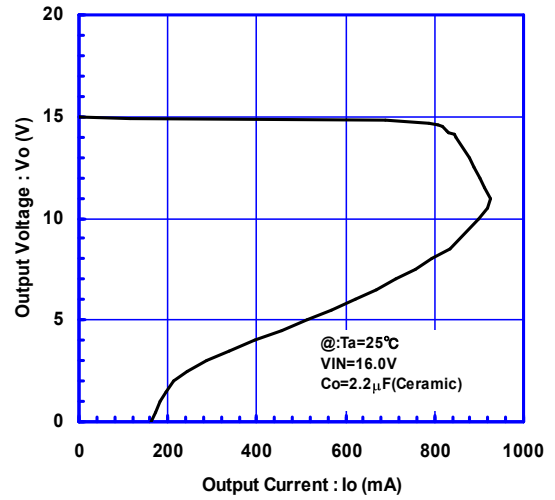

NJM2836\_15V  
Ground Current vs Output Current

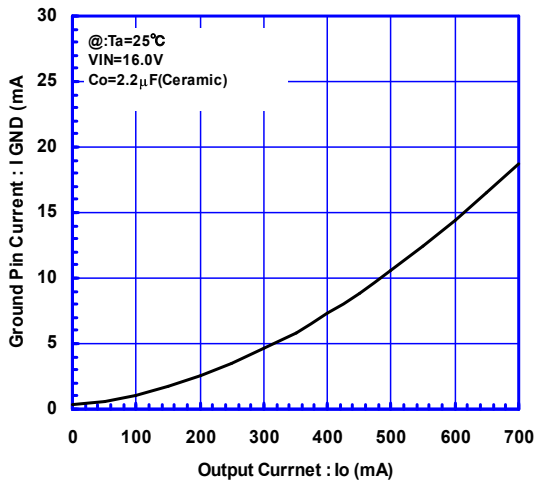

NJM2836\_15V  
Dropout Voltage VS Output Current

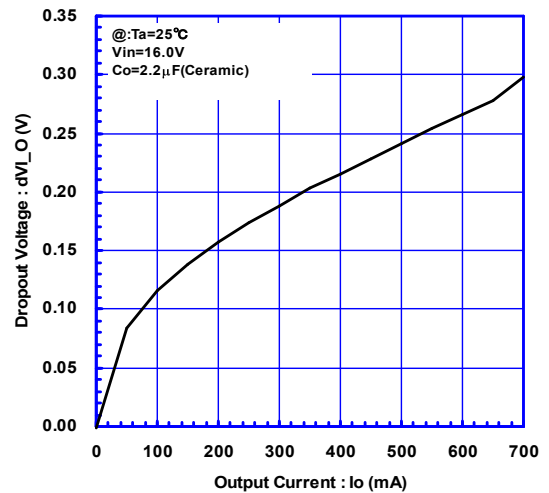

NJM2836\_15V  
Control Voltage vs Control Current

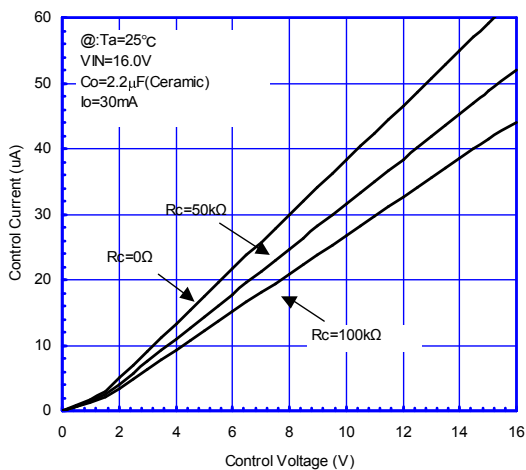

NJM2836\_15V  
Control Voltage vs Output Voltage

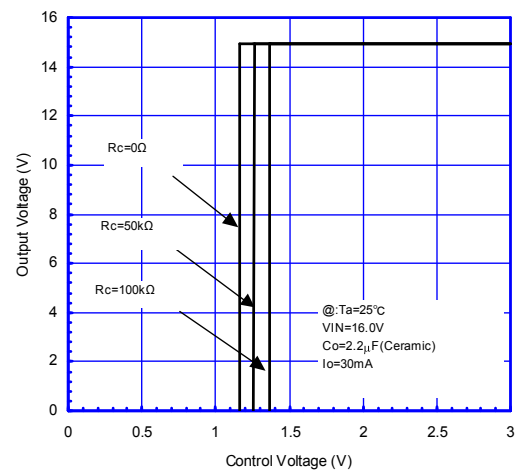

NJM2836\_15V  
Dropout Voltage VS Output Current

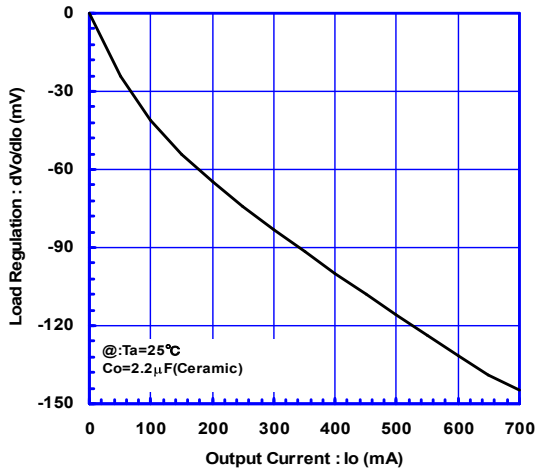

NJM2836\_15V  
Output Current vs Input Voltage

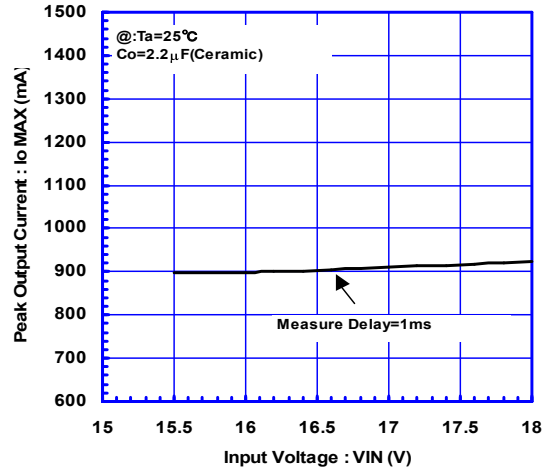

NJM2836\_15V  
Quiescent Current vs Input Voltage

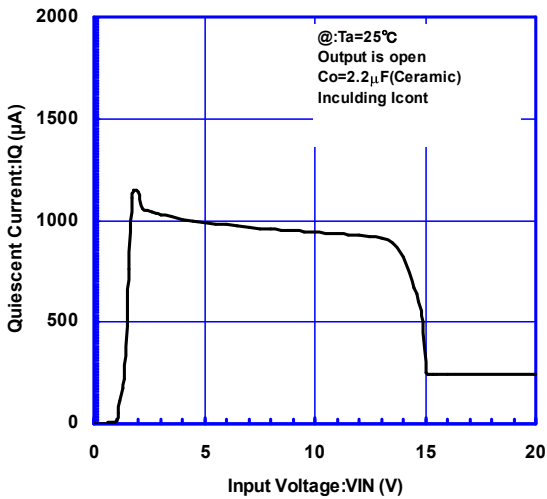

NJM2836\_15V  
Output Noise Voltage vs Output Current

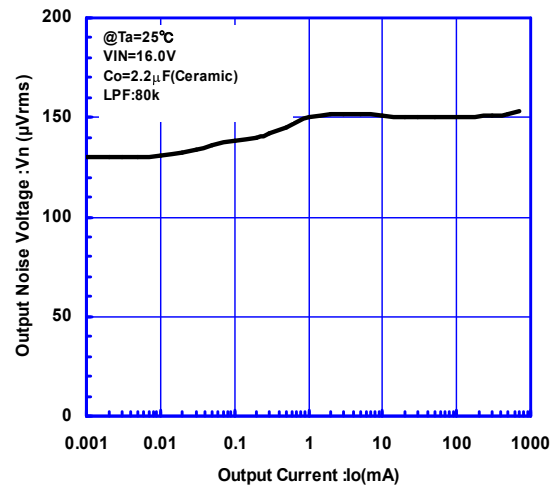

NJM2836\_15V  
Ripple Rejection

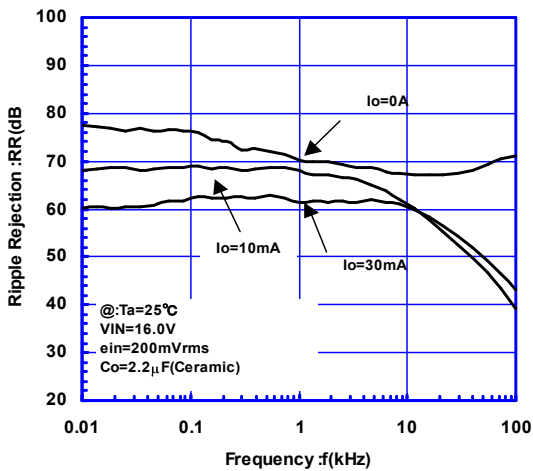

NJM2836\_15V  
Output Current vs Ripple Rejection

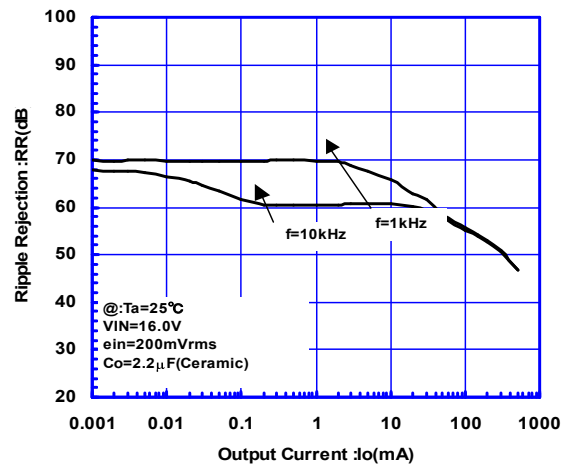



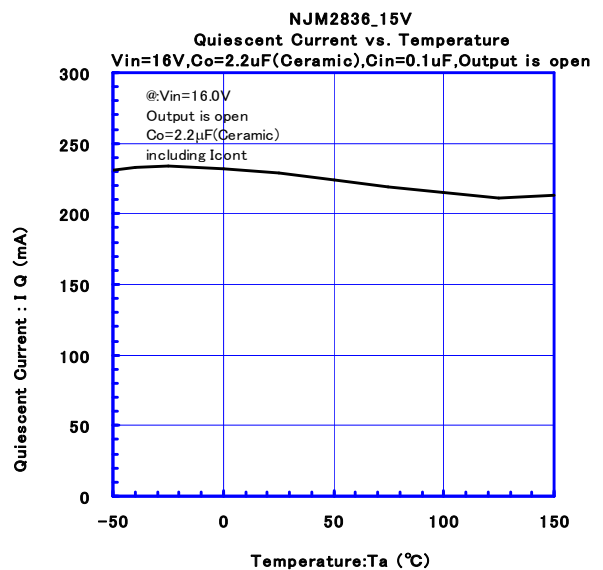
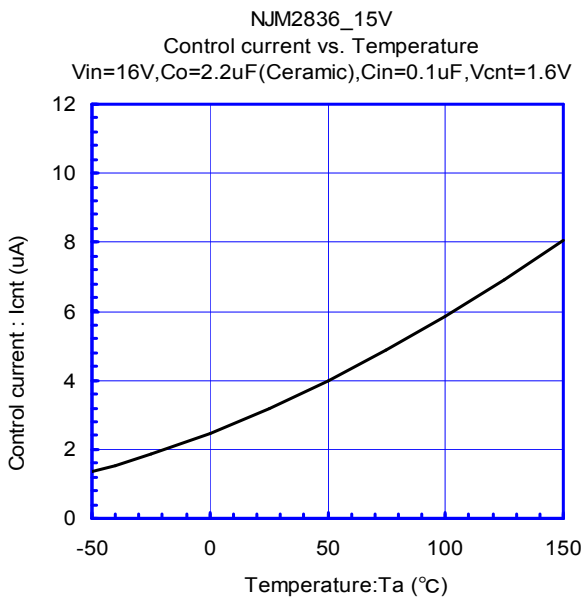
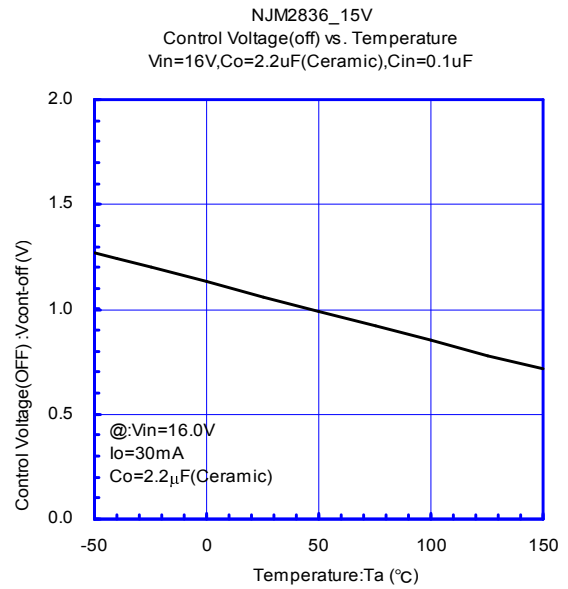
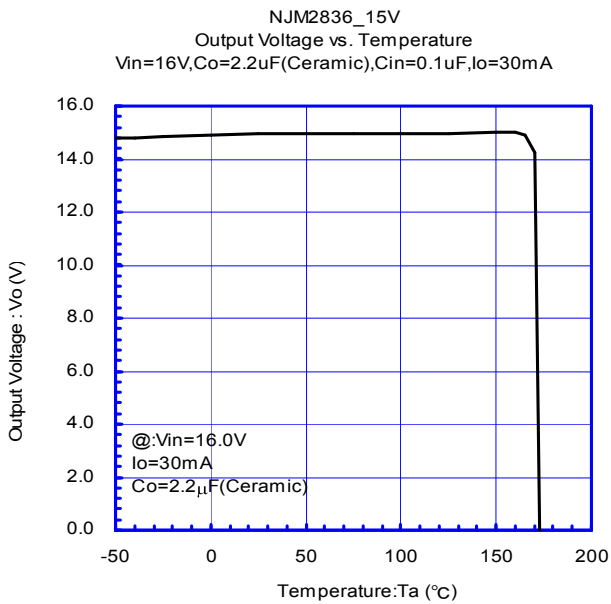
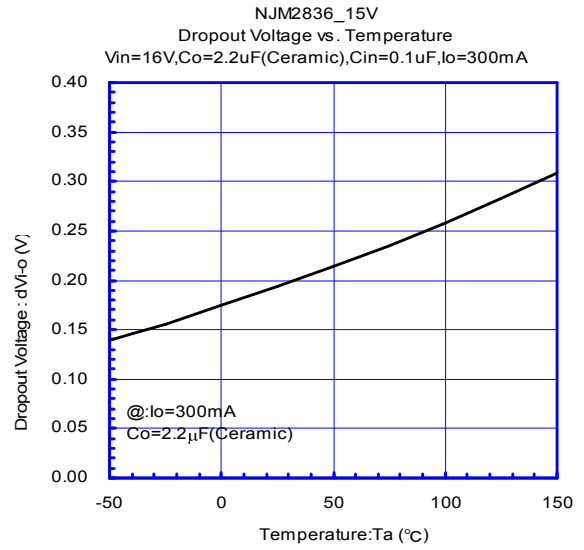
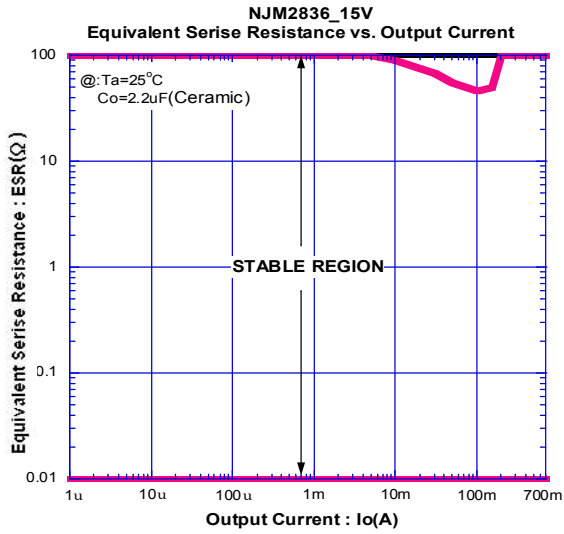

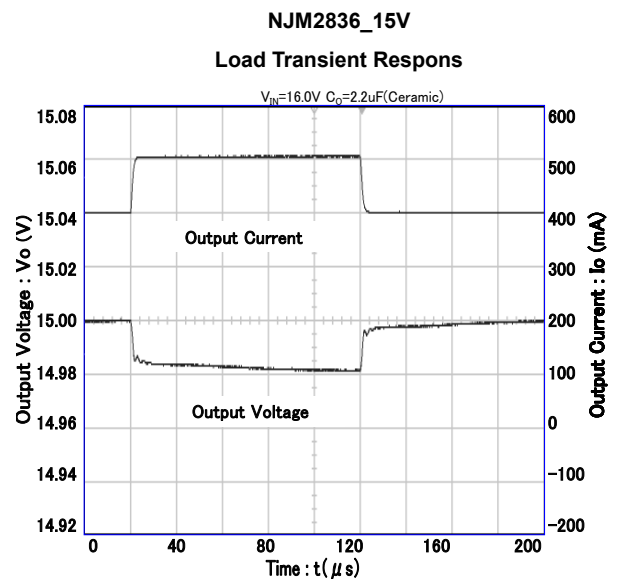
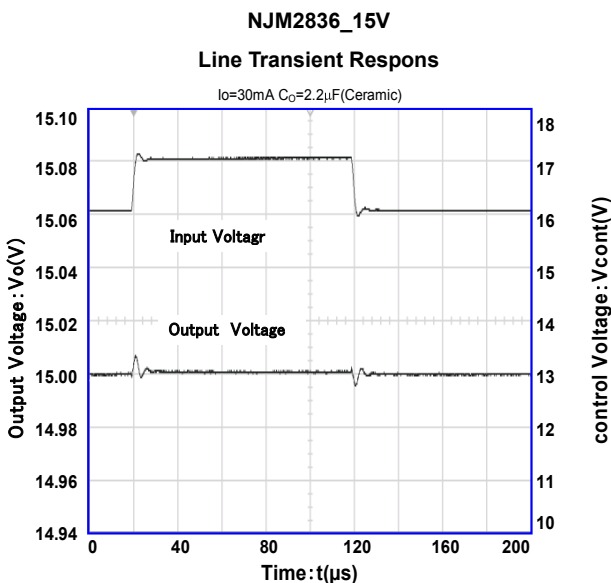
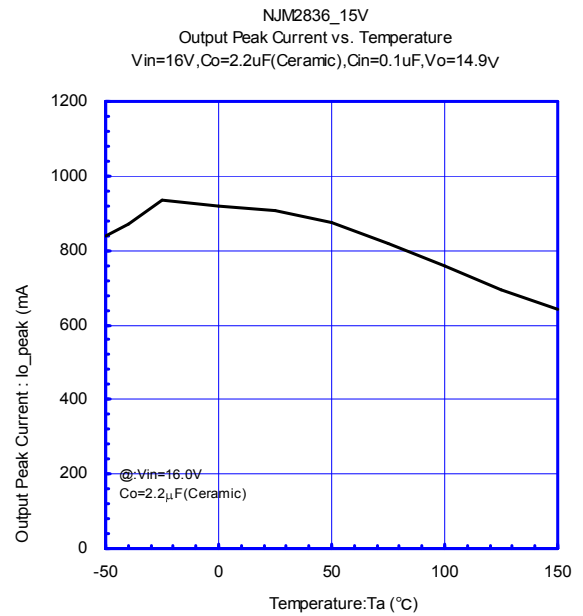
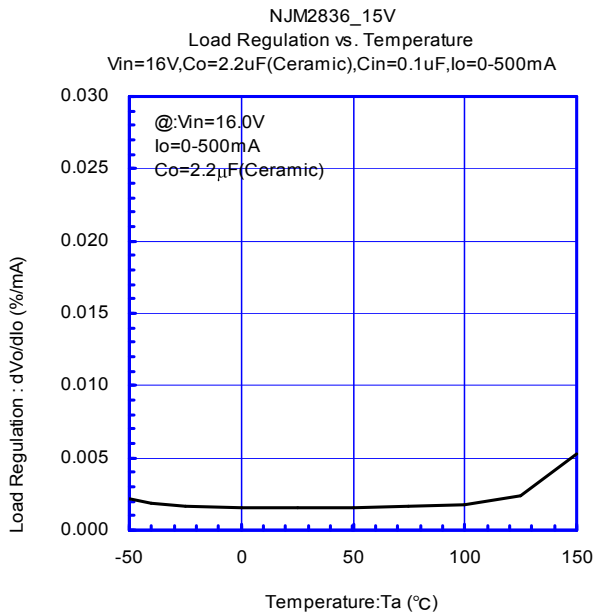
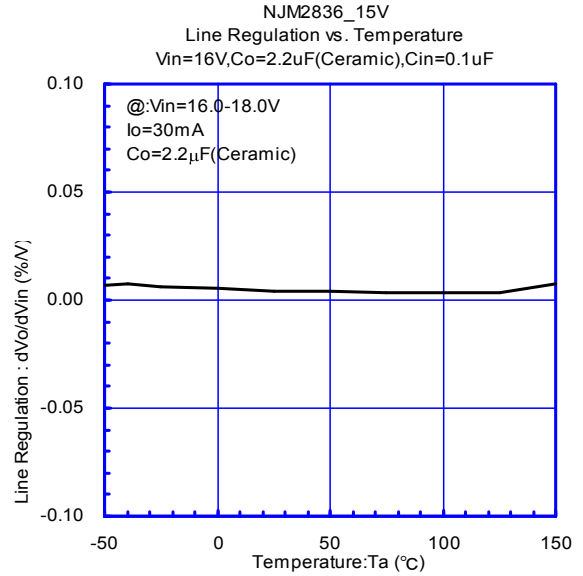
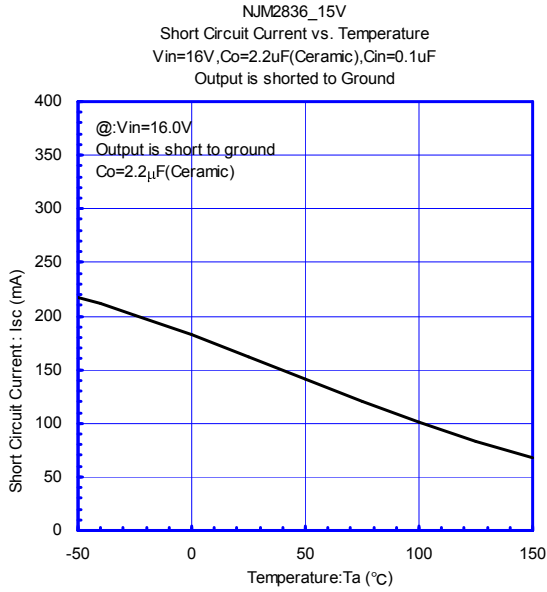

[CAUTION]  
The specifications on this databook are only given for information, without any guarantee as regards either mistakes or omissions. The application circuits in this databook are described only to show representative usages of the product and not intended for the guarantee or permission of any right including the industrial rights.