

EiceDRIVER™

High voltage gate driver IC

1EDS-SRC family

Real-time adjustable gate current control IC

1EDS20I12SV

1EDU20I12SV

1EDI20I12SV

EiceDRIVER™

Final datasheet

<Revision 2.3>, 31.1.2020

Industrial Power Control

Edition 31.1.2020

**Published by
Infineon Technologies AG
81726 Munich, Germany**

**© 2020 Infineon Technologies AG
All Rights Reserved.**

IMPORTANT NOTICE

The information given in this document shall in no event be regarded as a guarantee of conditions or characteristics ("Beschaffenheitsgarantie").

With respect to any examples, hints or any typical values stated herein and/or any information regarding the application of the product, Infineon Technologies hereby disclaims any and all warranties and liabilities of any kind, including without limitation warranties of non-infringement of intellectual property rights of any third party.

In addition, any information given in this document is subject to customer's compliance with its obligations stated in this document and any applicable legal requirements, norms and standards concerning customer's products and any use of the product of Infineon Technologies in customer's applications.

The data contained in this document is exclusively intended for technically trained staff. It is the responsibility of customer's technical departments to evaluate the suitability of the product for the intended application and the completeness of the product information given in this document with respect to such application.

Please note that this product is not qualified according to the AEC Q100 or AEC Q101 documents of the Automotive Electronics Council.

WARNINGS

Due to technical requirements products may contain dangerous substances. For information on the types in question please contact your nearest Infineon Technologies office.

Except as otherwise explicitly approved by Infineon Technologies in a written document signed by authorized representatives of Infineon Technologies, Infineon Technologies' products may not be used in any applications where a failure of the product or any consequences of the use thereof can reasonably be expected to result in personal injury.

Revision History

Page or Item	Subjects (major changes since previous revision)
<Revision 2.3>, 31.1.2020	
5.2	Added clause regarding VDE 0884-10 quarterly monitoring..
all	Changed isolation characteristics regarding VDE 0884-10 expiration date. Product and testing remain unchanged.

Trademarks of Infineon Technologies AG

AURIX™, BlueMoon™, C166™, CanPAK™, CIPOS™, CIPURSE™, COMNEON™, EconoPACK™, CoolMOS™, CoolSET™, CORECONTROL™, CROSSAVE™, DAVE™, EasyPIM™, EconoBRIDGE™, EconoDUAL™, EconoPIM™, EiceDRIVER™, eupec™, FCOS™, HITFET™, HybridPACK™, I²RF™, ISOFACE™, IsoPACK™, MIPAQ™, ModSTACK™, my-d™, NovalithIC™, OmniTune™, OptiMOS™, ORIGA™, PRIMARION™, PrimePACK™, PrimeSTACK™, PRO-SIL™, PROFET™, RASIC™, ReverSave™, SatRIC™, SIEGET™, SINDRION™, SIPMOS™, SMARTi™, SmartLEWIS™, SOLID FLASH™, TEMPFET™, thinQ!™, TRENCHSTOP™, TriCore™, X-GOLD™, X-PMU™, XMM™, XPOSYS™.

Other Trademarks

Advance Design System™ (ADS) of Agilent Technologies, AMBA™, ARM™, MULTI-ICE™, KEIL™, PRIMECELL™, REALVIEW™, THUMB™, μVision™ of ARM Limited, UK. AUTOSAR™ is licensed by AUTOSAR development partnership. Bluetooth™ of Bluetooth SIG Inc. CAT-iq™ of DECT Forum. COLOSSUS™, FirstGPS™ of Trimble Navigation Ltd. EMV™ of EMVCo, LLC (Visa Holdings Inc.). EPCOS™ of Epcos AG. FLEXGO™ of Microsoft Corporation. FlexRay™ is licensed by FlexRay Consortium. HYPERTERMINAL™ of Hilgraeve Incorporated. IEC™ of Commission Electrotechnique Internationale. IrDA™ of Infrared Data Association Corporation. ISO™ of INTERNATIONAL ORGANIZATION FOR STANDARDIZATION. MATLAB™ of MathWorks, Inc. MAXIM™ of Maxim Integrated Products, Inc. MICROTEC™, NUCLEUS™ of Mentor Graphics Corporation. Mifare™ of NXP. MIPI™ of MIPI Alliance, Inc. MIPS™ of MIPS Technologies, Inc., USA. muRata™ of MURATA MANUFACTURING CO., MICROWAVE OFFICE™ (MWO) of Applied Wave Research Inc., OmniVision™ of OmniVision Technologies, Inc. Openwave™ Openwave Systems Inc. RED HAT™ Red Hat, Inc. RFMD™ RF Micro Devices, Inc. SIRIUS™ of Sirius Satellite Radio Inc. SOLARIS™ of Sun Microsystems, Inc. SPANSION™ of Spansion LLC Ltd. Symbian™ of Symbian Software Limited. TAIYO YUDEN™ of Taiyo Yuden Co. TEAKLITE™ of CEVA, Inc. TEKTRONIX™ of Tektronix Inc. TOKO™ of TOKO KABUSHIKI KAISHA TA. UNIX™ of X/Open Company Limited. VERILOG™, PALLADIUM™ of Cadence Design Systems, Inc. VLYNQ™ of Texas Instruments Incorporated. VXWORKS™, WIND RIVER™ of WIND RIVER SYSTEMS, INC. ZETEX™ of Diodes Zetex Limited.

Last Trademarks Update 2010-10-26

Table of Contents

1	Block diagram	7
2	Pin configuration, description, and functionality	8
2.1	Terminal configuration	8
2.2	Terminal functionality	9
3	Functional description	13
3.1	Introduction.....	13
3.2	IC Supply.....	13
3.2.1	Input side.....	14
3.2.2	Output side	14
3.3	Non-inverting and inverting input terminals INP and INN	14
3.4	Driver output terminal ON	14
3.5	SPEED setting.....	15
3.6	Preboost setting	16
3.7	Gate turn-off terminal OFF	16
3.8	Terminal EN	17
3.9	Protection and diagnosis features.....	17
3.9.1	Undervoltage lockout (UVLO)	17
3.9.2	Ready and status output terminals.....	17
3.9.3	Fault indication (terminal /FLT)	18
3.9.4	Watchdog	18
3.9.5	I/O signature check	18
3.9.6	Two-level turn-off (TLTO).....	19
3.9.7	Desaturation shut down protection.....	19
3.9.8	IGBT overcurrent detection	19
3.9.9	Overcurrent protection ON/OFF	20
3.9.10	Soft turn-off.....	20
4	Electrical parameters	21
4.1	Absolute maximum ratings.....	21
4.2	Operating range	22
4.3	Electrical characteristics.....	23
4.3.1	Voltage supply.....	23
4.3.2	Logic input and output.....	24
4.3.3	Gate driver.....	24
4.3.4	Desaturation protection	26
4.3.5	Overcurrent protection disable	26
4.3.6	Current sense.....	26
4.3.7	Two-level turn-off.....	27
5	Insulation characteristics	28
5.1	Tested according to VDE 0884-10 (Standard expired on Dec. 31, 2019, 1EDS20I12SV only)	28
5.2	Recognized under UL 1577 (File E311313, 1EDS20I12SV and 1EDU20I12SV only)	28
6	Timing diagrams	29
7	Package	32
7.1	PG-DSO-36-64.....	32

List of Figures

Figure 1	Block diagram for the 1EDS-SRC family	7
Figure 2	Terminal configuration of the 1EDS-SRC family (Top View)	8
Figure 3	Typical application.....	13
Figure 4	Timing diagram for turn-on.....	15
Figure 5	External circuit for setting of preboost current (left: unipolar supply; right: bipolar supply)	16
Figure 6	I/O signature check	18
Figure 7	Timing of turn-on and turn-off propagation delay without two-level turn-off mode	29
Figure 8	Timing of EN turn-on and shut down propagation delay	29
Figure 9	Timing of short pulse suppression terminal INP and SIGI ($T_P < T_{FILIN}$).....	29
Figure 10	Timing of short pulse suppression terminal INN ($T_P < T_{FILIN}$).....	29
Figure 11	Timing of short pulse suppression terminal EN ($T_P < T_{FILIN}$)	30
Figure 12	Timing for fault reset at terminal EN.....	30
Figure 13	Timing of CS events incl. terminals SOFF, /FLT and EN.....	30
Figure 14	Timing for DESAT events incl. terminals SOFF, /FLT and EN (timing is same for related INN input signal).....	31
Figure 15	Timing for two-level turn-off incl. terminals CZ and OFF (top: $T_{TLSET} < T_{TLLIM}$, bottom: $T_{TLSET} > T_{TLLIM}$).....	31
Figure 16	Package drawing.....	32
Figure 17	PCB reference layout (left: top layer, right: bottom layer)	33

List of Tables

Table 1	Terminal Description	8
Table 2	Switching speed levels on input and output side	16
Table 3	Driver IC status for EN, INP, and INN	17
Table 4	Driver IC status UVLO at VCC1, VCC2 and PADP (EN = high)	18
Table 5	Abs. maximum ratings.....	21
Table 6	Operating parameters	22
Table 7	Voltage supply.....	23
Table 8	Logic input and output.....	24
Table 9	Gate driver.....	24
Table 10	Desaturation protection	26
Table 11	Overcurrent protection disable	26
Table 12	Current sense.....	26
Table 13	Two-level turn-off.....	27
Table 14	Insulation characteristics	28
Table 15	Tested for reinforced isolation limits according to VDE 0884-10 (Standard expired on Dec. 31, 2019, 1EDS20I12SV only)	28
Table 16	Recognized under UL 1577	28

EiceDRIVER™
Real-time adjustable gate current control IC
Main features

- Single-channel isolated IGBT Driver
- Supports IGBT up to 1200 V
- IGBT off-state: 2 A pull down to rail
- Overcurrent protection for sense IGBTs and conventional IGBTs
- Desaturation detection
- Soft turn-off shut down: 1 A pull down to rail
- Two-level turn-off
- Operation at high ambient temperature up to 105°C
- Compatible PWM inputs for 3.3 V, 5 V, and 15 V logic voltages

1EDS20I12SV
 1EDU20I12SV
 1EDI20I12SV

Product highlights

- Optimized short circuit control for 3-level inverters
- Online adjustable current source slew rate control during IGBT turn-on
- UL certification according UL1577 ($V_{ISO} = 5 \text{ kV}$, 1EDS20I12SV and 1EDU20I12SV only)
- Isolation tested according VDE 0884-10 (standard expired Dec. 31, 2019, $V_{IORM}=1420\text{V}$, 1EDS20I12SV only)

Potential applications

- AC and brushless DC motor drives
- High-voltage DC/DC converters
- UPS systems
- Welding
- Servo drives

Description

The 1EDS20I12SV is a single-channel IGBT driver in a PG-DSO-36-64 package with a galvanically isolated barrier according UL1577 and testing according to VDE0884-10. The driver IC controls three external p-channel MOSFET or even more as a controlled current source during turn-on. The IC is therefore able to control precisely the turn-on process in order to avoid excessive dV_{CE}/dt or dI_C/dt transients. The IC has a peak sinking capability of 2 A for turning off the IGBT. An external PNP transistor can be used to support IGBT with currents ratings higher than 75 A.

The 1EDU20I12SV offers the same set of function including a galvanically isolated barrier according to UL1577.

The 1EDI20I12SV offers the same set of functions including the unique slew rate control with the exception that its isolation barrier offers functional isolation.

All three devices together are the 1EDS-SRC family.

The logic input pins of the 1EDS-SRC family are 3.3 V, 5 V, and 15 V CMOS-compatible. The data transfer across the galvanic isolation barrier is accomplished with the integrated coreless transformer technology. The 1EDS-SRC family provides several protection features such as IGBT desaturation shut down protection for IGBT, overcurrent protection for sense IGBT, soft turn-off shut down, and two-level turn-off.

1 Block diagram

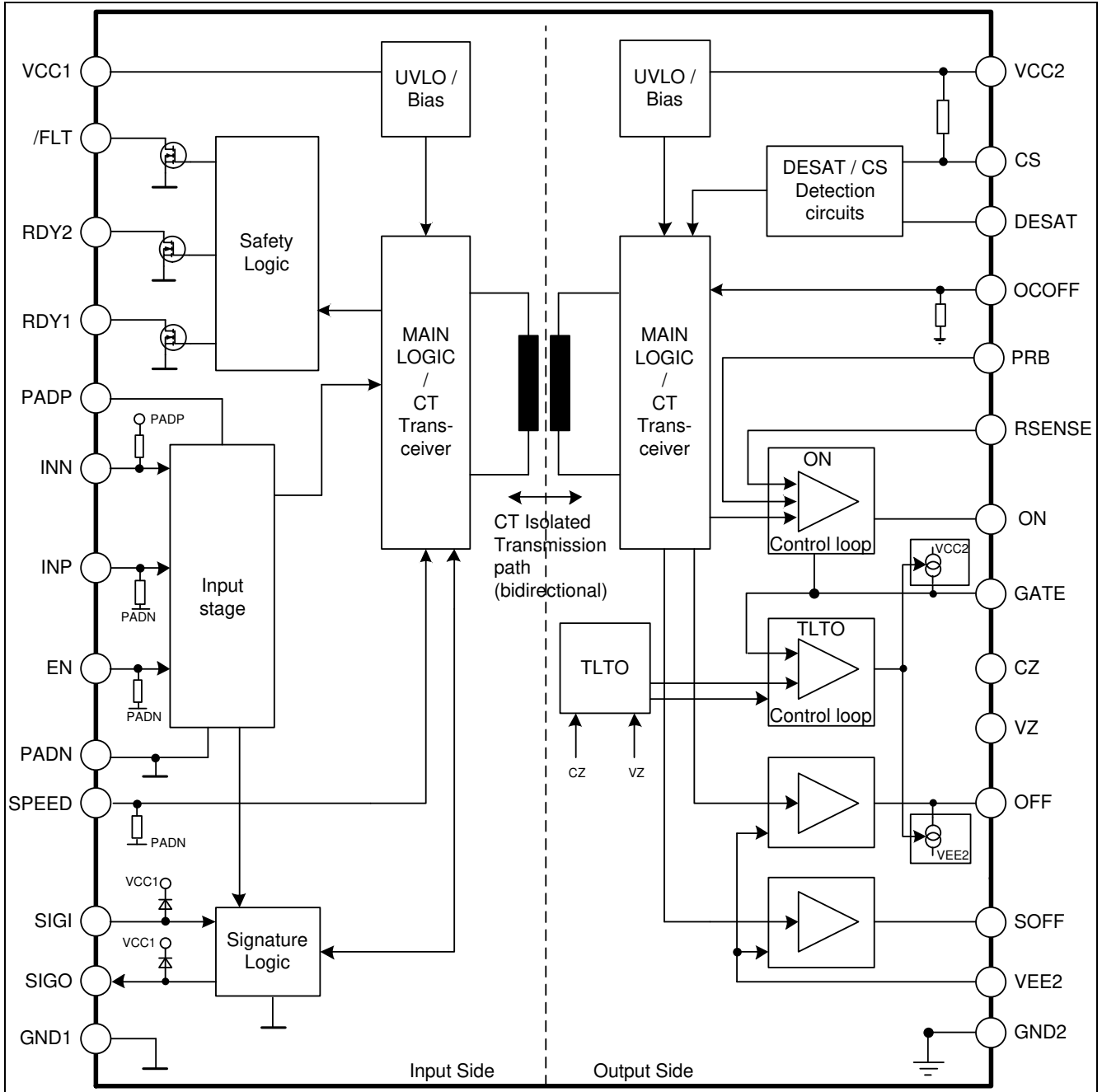

Figure 1 Block diagram for the 1EDS-SRC family

2 Pin configuration, description, and functionality

2.1 Terminal configuration

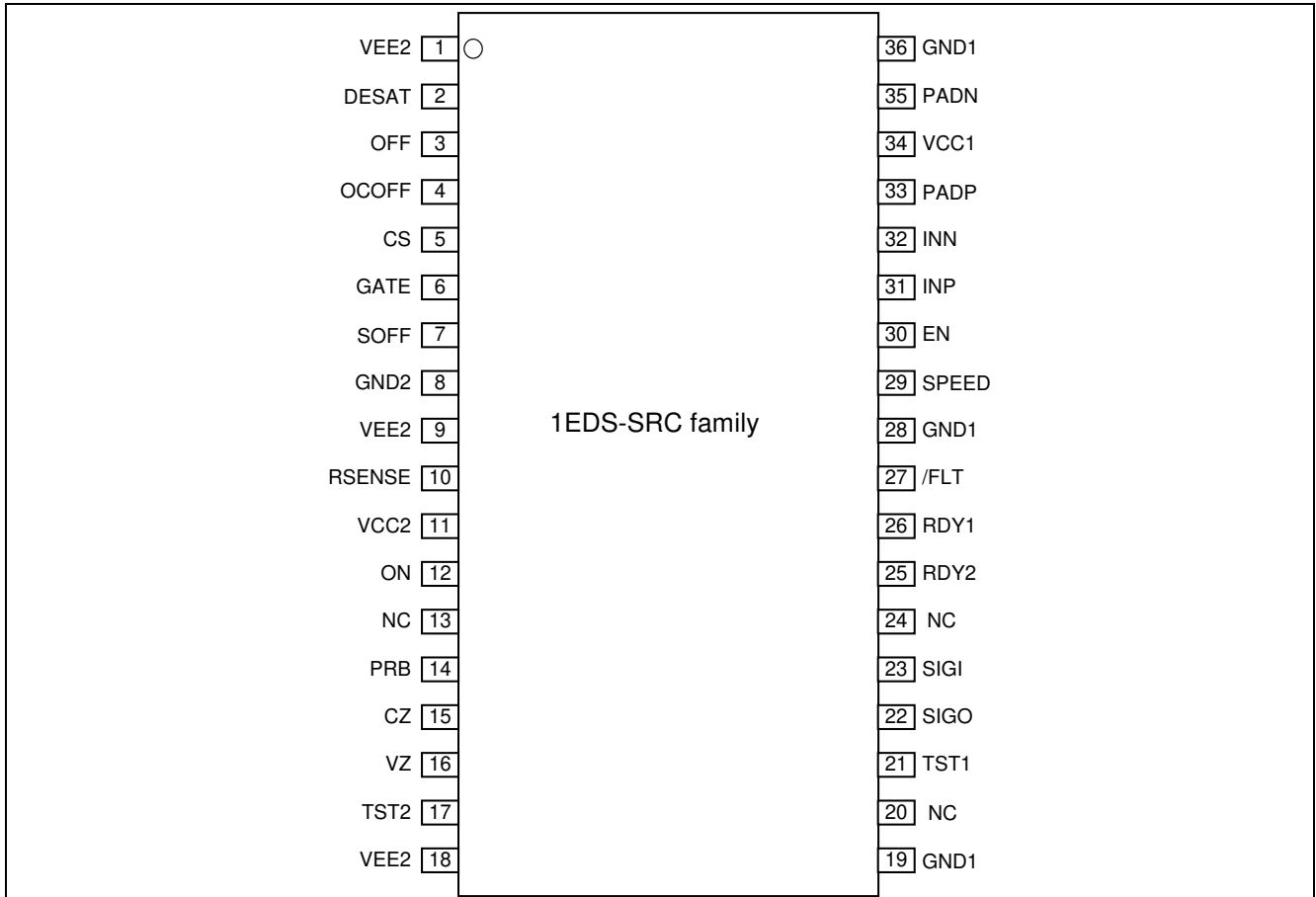

Figure 2 Terminal configuration of the 1EDS-SRC family (Top View)

Table 1 Terminal Description

Terminal number	Terminal name	Description
1	VEE2	Negative power supply, output side
2	DESAT	Desaturation shut down protection
3	OFF	Gate turn-off
4	OCOFF	Overcurrent protection on/off
5	CS	Sense IGBT overcurrent
6	GATE	Gate voltage sense
7	SOFF	Gate soft turn-off
8	GND2	Signal ground, output side
9	VEE2	Negative power supply, output side
10	RSENSE	Sense resistor input
11	VCC2	Positive power supply, output side

Table 1 Terminal Description

Terminal number	Terminal name	Description
12	ON	Gate control for external p-channel MOSFET
13	NC	Not connected, connection to GND2 recommended
14	PRB	Preboost current adjustment
15	CZ	Two-level turn-off time set
16	VZ	Two-level turn-off voltage set
17	TST2	Reserved terminal, to be connected to VEE2
18	VEE2	Negative power supply, output side
19	GND1	Ground, input side
20	NC	Not connected, connection to GND1 recommended
21	TST1	Reserved terminal, to be connected to GND1
22	SIGO	Signature test output
23	SIGI	Signature test input
24	NC	Not connected, connection to GND1 recommended
25	RDY2	Ready signal, monitoring the output side
26	RDY1	Ready signal, monitoring the input side
27	/FLT	Fault output
28	GND1	Ground, input side
29	SPEED	Setting of IGBT gate current level (analog)
30	EN	Enable, shutdown, and fault reset input
31	INP	Non-inverting driver input
32	INN	Inverting driver input
33	PADP	Input side logic reference voltage
34	VCC1	Positive power supply, input side
35	PADN	Input side logic reference ground
36	GND1	Ground, input side

2.2 Terminal functionality

GND1

Logic ground terminal of the input side.

PADN

Input side logic reference ground. Direct connection to GND1 is required.

VCC1

5 V power supply for the input side.

The reference terminal for VCC1 is GND1.

PADP

3.3 V, 5 V or 15 V input side logic reference voltage.

The reference terminal for PADP is PADN.

INN inverting driver input

INN control signal for the driver output while INP is set to high. The IGBT is turned on, if INN is set to low, and is turned off, if INN is set to high, respectively. A minimum pulse width is required to prevent from glitches while controlling the IGBT. An internal pull-up resistor ensures that the IGBT is kept in off-state, if terminal INN is left unconnected.

The reference terminal for INN is PADN.

INP non-inverting driver input

INP control signal for the driver output while INN is set to low. The IGBT is turned on, if INP is set to high, and is turned off, if INP is set to low, respectively. A minimum pulse width is required to suppress glitches while controlling the IGBT. An internal pull-down resistor ensures that the IGBT is kept in off-state, if terminal INP is left unconnected.

The reference terminal for INP is PADN.

EN input

Terminal EN needs to be set high for INP and INN to control the IGBT switching.

The EN input terminal serves two purposes:

Feature 1: Enable / shutdown of the output side. The IGBT is turned off by a soft turn-off, if terminal EN is set to low. A minimum pulse width is defined to help suppress glitches on terminal EN.

The IGBT is switched on without preboost on the rising edge of terminal EN, if terminal INP is set high and terminal INN is set low before activating EN.

Feature 2: Resets the desaturation or overcurrent condition signaled on terminal /FLT, if terminal EN is set to low for more than 870 ns. A reset of signal /FLT is asserted at the rising edge of terminal EN.

The reference terminal for EN is PADN.

SPEED

IGBT on-state gate current setting sent from input side. This is an analog input terminal. The reference voltage of the internal ADC is PADP. The reference terminal for SPEED is PADN.

/FLT fault output

Open-drain output terminal to signal desaturation of conventional IGBTs or overcurrent of sense IGBTs. Terminal /FLT is set low, if desaturation or overcurrent occurs. The /FLT terminal has to be connected via a pull-up resistor to PADP.

The reference terminal for /FLT is GND1.

RDY1 ready status

Open-drain output to signal the proper operation of the input side. RDY1 is set to high if the input side terminals VCC1 and PADP are above their respective undervoltage thresholds. The RDY1 terminal should be connected via a pull-up resistor to PADP.

The reference ground terminal for RDY1 is GND1.

RDY2 ready status

Open-drain output to signal the proper operation of the output side. RDY2 is set to high, if the output side supply is above the UVLO2 level and the internal chip data transmission is operating properly. The RDY2 terminal should be connected via a pull-up resistor to PADP.

The reference ground terminal for RDY2 is GND1.

SIGI

I/O signature check input terminal.

The reference terminal for SIGI is GND1.

SIGO

I/O signature check output terminal

The reference terminal for SIGO is GND1.

TST1

Terminal TST1 is a reserved terminal and has to be connected to GND1.

TST2

TST2 is a reserved terminal and has to be connected to VEE2.

VEE2

Negative power supply terminal for the output side: All VEE2 terminals must be connected to GND2, if no separate negative supply voltage is used.

DESAT

Monitoring of the IGBT saturation voltage $V_{CE(sat)}$ to detect desaturation caused by a short: The IGBT is shut down by activating soft turn-off, if the voltage at this pin is above a given threshold. Two additional filters provide a large robustness against noise and coupling effects. One of these filters is adjustable in terms of the filter time.

The reference terminal for DESAT is GND2.

OFF

Gate turn-off terminal in normal operation mode

The reference terminal for OFF is VEE2.

OCOFF

Input terminal to inhibit the automatic turn-off of the IGBT in case of a desaturation or current sense failure. The fault status continues to be signaled on terminal /FLT. This feature is deactivated by an internal pull-down resistor to GND2, if the terminal is left open.

The reference terminal for OCOFF is GND2

CS

Current sense comparator input terminal for sense IGBTs or standard IGBTs with external emitter shunts.

The reference terminal for CS is GND2. This feature is deactivated, if terminal CS is connected to GND2.

GATE

Input terminal for sensing the gate voltage at resistor ROFF, for example according to Figure 3.

The reference terminal for GATE is GND2.

PRB

The preboost current is adjusted by means of a voltage divider between GND2 and VEE2 for a bipolar supply. The voltage divider is connected to VCC2 and VEE2 for unipolar supply.

The reference terminal for PRB is VEE2.

SOFF

Output terminal for IGBT soft turn-off in case of short circuit or overcurrent events

The reference terminal for SOFF is VEE2.

GND2

Reference ground terminal of the output side.

RSENSE

Current sense feedback input of the turn-on gate current control loop.
The reference terminal for RSENSE is VCC2.

VCC2

Positive power supply terminal of the output side.

ON

Terminal for the connection to the gate terminal of an external p-channel MOSFET, such as OptiMOS™ BSD314SPE. This transistor is used to control the IGBT turn-on gate current.

The reference terminal for ON is VCC2.

CZ

This terminal sets the two-level turn-off timing via an external capacitor against VEE2. A short between terminals CZ and VEE2 deactivates the two-level turn-off.

The reference terminal for CZ is VEE2.

VZ

Voltage adjustment terminal for the two-level turn-off feature: This terminal can be connected to VEE2 via a resistor of 27 kΩ ($V_{TLTO} = 9.3$ V), shorted against VEE2 ($V_{TLTO} = 11.4$ V), or left floating ($V_{TLTO} = 10.3$ V).

The reference terminal for VZ is VEE2.

3 Functional description

3.1 Introduction

The 1EDS-SRC family is an advanced IGBT gate driver family with various control and protection features to allow the design of highly reliable systems. The integrated circuit consists of two galvanically isolated sides, called input side and output side. The input side is typically interfaced with a CMOS-compatible DSP or a microcontroller. The galvanically isolated output side is connected to the high voltage domain. The adjustable gate current source allows the tuning of the IGBT turn-on slew rate to control the EMI of power electronic systems.

The turn-off process is accomplished with an internal MOSFET stage capable of driving 2 A. An internal MOSFET switch capable of driving 1 A could be connected to an external gate resistor with higher resistance to prevent from an overvoltage at the IGBT in case of a short circuit or an overcurrent shut down.

The driver also includes IGBT desaturation protection for conventional IGBTs and overcurrent protection for sense IGBTs with the fault status signal at the input side. Two ready status output terminals indicate whether the driver is properly supplied and operates normally. A two-level turn-off feature with adjustable delay protects against excessive overvoltage at turn-off in case of an overcurrent or a short. The same delay is applied at turn-on to prevent pulse width distortions.

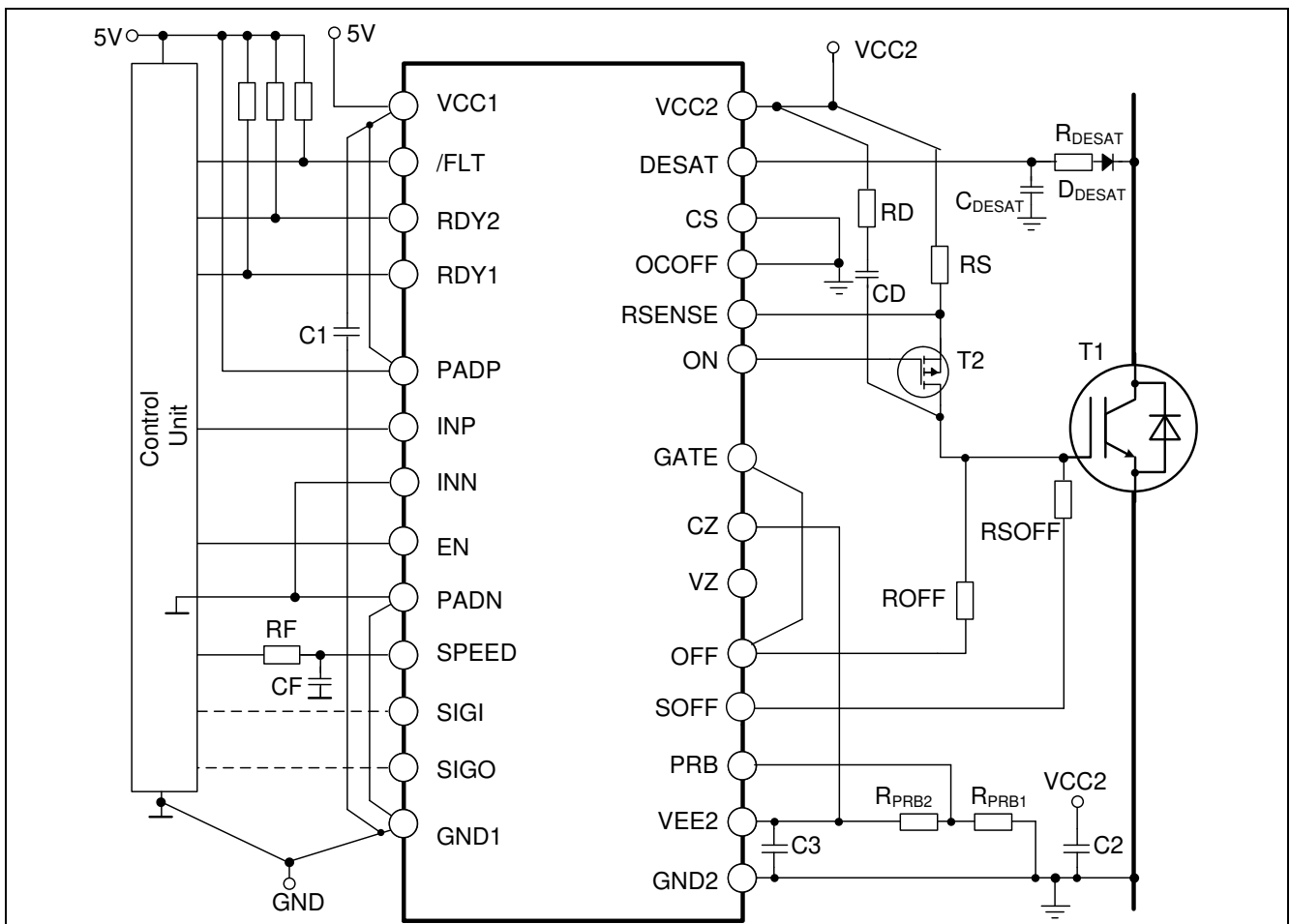

Figure 3 Typical application

3.2 IC Supply

There are three supply voltage domains available having individual undervoltage lockout levels. The IC is in a safe state during undervoltage lockout of any domain under all circumstances, meaning that the gate drive outputs are never activated before each part of the IC is ready to operate.

3.2.1 Input side

The driver is supplied with 5 V between terminals VCC1 to GND1. This supply voltage manages the basic functions of the input side. The input side contains a second voltage domain for the logic input signals INP, INN, and EN. This special voltage domain is supplied by the terminals PADP and PADN and can range from 3.3V over 5V to 15V. It is mandatory to connect directly the terminals PADN and GND1. It is important to note, that the voltage domains VCC1 and PADP have independent undervoltage lockout levels and both domains must be supplied appropriately for operation.

VCC1 can be shorted to GND1 in order to deactivate the driver. No turn-on signals will be transmitted from the input to the output side even if terminal VCC1 is left floating. Therefore, the IGBT won't be turned on.

3.2.2 Output side

The EiceDRIVER™ 1EDS-SRC family is designed to support both bipolar and unipolar power supply configurations. The driver IC is typically supplied with a positive voltage of 15 V on terminal VCC2 and a negative voltage of -8 V on terminal VEE2, if configured for bipolar supply. The driver IC is typically supplied with a positive voltage of 15 V on terminal VCC2 for a unipolar supply configuration. VEE2 and GND2 have to be connected together as short as possible for unipolar supply.

3.3 Non-inverting and inverting input terminals INP and INN

There are two input modes to control the IGBT. In non-inverting mode, terminal INP controls the driver output while terminal INN is set to low. In inverting mode, terminal INN controls the driver output while terminal INP is set to high. A low signal at terminal INN will activate the output ON. A minimum input pulse width is defined to suppress potential glitches.

3.4 Driver output terminal ON

The output side contains an integrated feedback control for the IGBT gate current. The gate current control is completed by the external current sense resistor and a p-channel MOSFET. Several resistors and MOSFETs can be placed in parallel in order to limit the individual power dissipation. The recommended P-channel transistor is BSD314SPE (OptiMOS™-P 3, 30 V, 140 mΩ).

The entire turn-on procedure of an IGBT is separated into three phases according to Figure 4: the preboost, the turn-on, and the VCC2 clamping phase.

The preboost phase controls a high current to drive the gate of the IGBT. The gate voltage is increased from its starting point to a voltage lower than the gate-emitter threshold voltage of the IGBT, i.e. $V_{GATE} < V_{GE(th)}$, within a period of typ. 135 ns. It is important that the IGBT is not turned on during the preboost phase. The value of the preboost current I_{PRB} is proportional to the voltage V_{PRB} at terminal PRB. The preboost current I_{PRB} is defined as:

$$I_{PRB} = \left| \frac{2 \cdot V_{PRB}}{3 \cdot R_S} \right| \quad (1)$$

The change from the preboost phase into the turn-on phase needs less than typically 25 ns. This time must be considered for the setting of the preboost current amplitude in order not to overcharge the gate during the preboost phase.

The gate current during the turn-on phase can be selected out of 11 levels for the proper adjustment of the turn-on transition. The fine granularity between levels 1 and 10 allows accurate slope control. It behaves similar as a traditional driver at level 11. The driver controls the voltage drop across the sense resistor R_S . The corresponding gate current I_{gg} is

$$I_{gg} = \frac{V_{RSENSE}}{R_{SENSE}} \quad (2)$$

The selection of the gate current for the turn-on phase is accomplished with terminal SPEED on the input side. Terminal SPEED is an input terminal with voltage levels between 0 V and 3.3 V. The lowest voltage at terminal SPEED corresponds with the highest gate current level, e.g. by connecting SPEED to GND1.

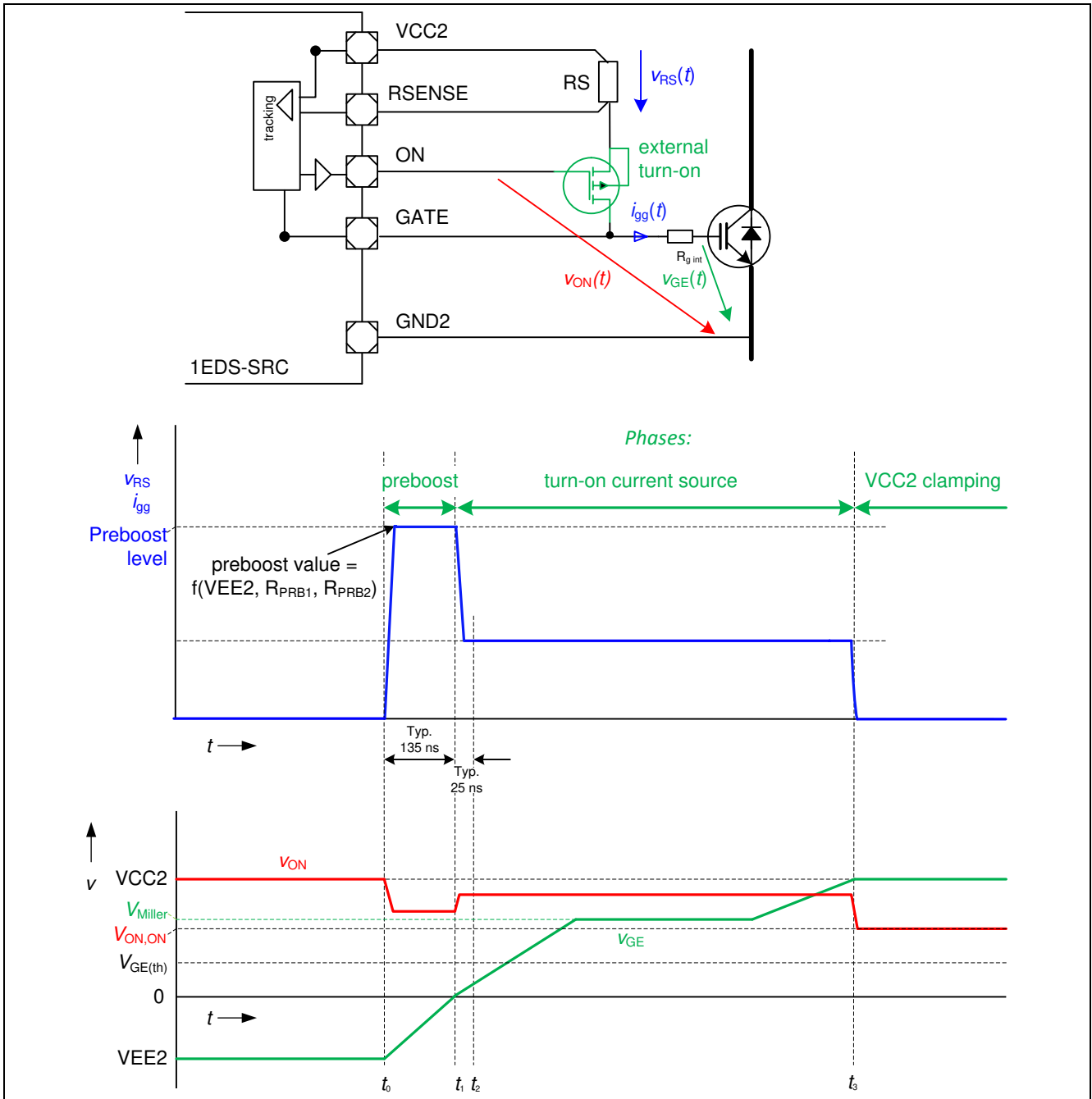

Figure 4 Timing diagram for turn-on

Finally, the IGBT gate voltage saturates at VCC2 in the VCC2 clamping phase. The driver clamps the gate voltage of the external P-channel transistor 6 V below VCC2 according to Figure 4. This provides a low-resistive connection between the gate of the IGBT and terminal VCC2

It is good board layout engineering to keep tightest proximity of the control loop consisting of driver IC, sense resistor, p-channel MOSFET, and the VCC2 / VEE2 blocking capacitors to avoid oscillations.

3.5 SPEED setting

The 11 levels of gate current can be selected by applying an analog voltage V_{SPEED} at terminal SPEED according to the table below.

Table 2 Switching speed levels on input and output side

	Voltage at terminal SPEED	Typ. reference V_{RSENSE}	% of turn-on gate current amplitude
Level 1	3.3 V	$V_{VCC2}-0.197$	20%
Level 2	2.91 V	$V_{VCC2}-0.287$	29%
Level 3	2.63 V	$V_{VCC2}-0.376$	38%
Level 4	2.35 V	$V_{VCC2}-0.466$	46%
Level 5	2.08 V	$V_{VCC2}-0.556$	56%
Level 6	1.80 V	$V_{VCC2}-0.645$	64%
Level 7	1.52 V	$V_{VCC2}-0.735$	73%
Level 8	1.25 V	$V_{VCC2}-0.825$	82%
Level 9	0.97 V	$V_{VCC2}-0.912$	91%
Level 10	0.69 V	$V_{VCC2}-1.003$	100%
Level 11	0	$V_{VCC2}-1.543$	154%

3.6 Preboost setting

The preboost control is always active, both in bipolar or unipolar power supply configuration. The only exception is, if the IGBT is turned on via EN according to section 3.8

The preboost current may be set by a simple voltage divider for bipolar gate supply as well as for unipolar supply. In case of bipolar power supply, connect the voltage divider between GND2, PRB, and VEE2. In case of a unipolar power supply, use VCC2, PRB, and VEE2 according to Figure 5.

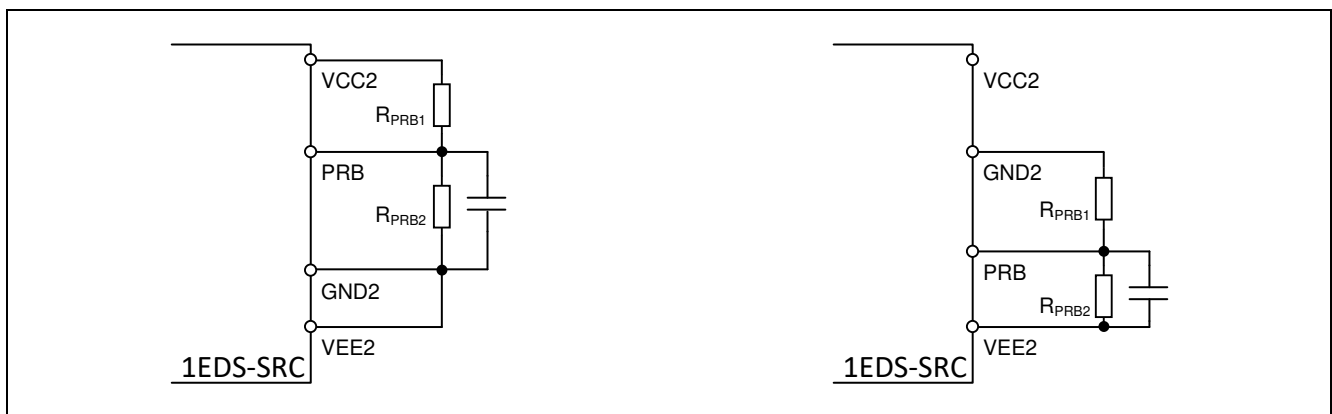

Figure 5 External circuit for setting of preboost current (left: unipolar supply; right: bipolar supply)

The selected preboost current amplitude should charge the IGBT gate from the negative voltage VEE2 to a value between 0 V and $V_{GE(th)}$ of the IGBT within 135 ns. The corresponding IGBT gate charge curves should be consulted for the various collector-emitter voltages V_{CE} for best accuracy.

3.7 Gate turn-off terminal OFF

The driver IC is able to sink a minimum gate current of 2 A peak. The closed loop controlled sink MOSFET establishes the two-level turn-off function according to section 3.9.6 by controlling the second level during the turn-off process for an adjustable time period T_{TLSET} . An external turn-off boost transistor is recommended for larger sink current capability.

3.8 Terminal EN

Terminal EN is used to enable the input side for normal operation. A soft turn-off is initiated, when the signal at terminal EN is logic low regardless of the status of signals at terminals INP and INN. The status of EN is dominant over all communications over the insulation barrier. If therefore a shutdown is initiated via terminal EN during normal operation and an overcurrent is detected simultaneously, the IGBT is turned off via soft turn-off. However, /FLT is not activated as the chip is already being reset. /FLT will be activated after IC enable, if the overcurrent still exists on the next IGBT turn-on command.

Signals on terminal EN have also priority over INN and INP. The signals at terminal EN have to pass a noise filter. The EN signal is suppressed, if the pulse duration is shorter than the filter time and the driver reacts as described in Table 3.

Table 3 Driver IC status for EN, INP, and INN

EN	INP	INN	Result
high	high	high	regular turn-off / soft off*
high	low	low	regular turn-off / soft off*
high	high ↑	low	turn-on
high	high	low ↓	turn-on
high ↑	high	low	turn-on without preboost
low ↓	high	low	Soft off

* soft turn-off only in case of simultaneous CS / DESAT event

A second function of the EN terminal is to reset the driver IC after an overcurrent event, which was triggered by the DESAT or CS function. The IC is reset by holding EN low. The fault indication at terminal /FLT follows on the next rising edge of signal EN

3.9 Protection and diagnosis features

3.9.1 Undervoltage lockout (UVLO)

The device is equipped with a system of defined undervoltage lockout (UVLO) levels on both the input and output side to ensure proper operation of the IGBT.

Any triggering of UVLO will turn-off the IGBT by means of the soft turn-off function. All signals at INP and INN are ignored until the voltage at terminals VCC1 recovers above V_{UVLOH1} at terminals VCC1 and V_{UVLOH3} at terminal PADP.

The IGBT is switched off via terminal OFF in case of an UVLO event at pin VCC2. Signals from the input side are ignored until VCC2 recovers to the power-up level of V_{UVLOH2} . The IC will perform an immediate turn-on after recovery of VCC2 according to Table 4.

3.9.2 Ready and status output terminals

The ready signal RDY1 for the input side covers the following conditions:

- UVLO status of the input side supply voltage domains at terminals VCC1 and PADP
- Establishment of correct signal transmission from input side to output side across the insulation barrier

The ready signal RDY2 for the output side indicates after a short delay:

- UVLO status of the output side supply voltage VCC2
- Establishment of bidirectional signal transmission across the insulation barrier

Both signals are monitoring signals only and need not to be reset actively.

Table 4 Driver IC status UVLO at VCC1, VCC2 and PADP (EN = high)

VCC1	VCC2	PADP	RDY1	RDY2	Result
UVLO ↓	good	good	low	X	SOFF and 5μs watchdog
UVLO ↑	good	good	high	high	acc. INP / INN (turn-on with preboost)
UVLO ↑	good	UVLO	low	high	OFF
good	UVLO ↓	good	high	low	activate OFF and SOFF simultaneously
good	UVLO ↑	good	high	high	acc. INP / INN (turn-on with preboost)
UVLO	UVLO ↑	good	low	high	OFF
X	X	UVLO ↓	low	high	SOFF and 5μs watchdog
good	good	UVLO ↑	high	high	acc. INP / INN (turn-on with preboost)

3.9.3 Fault indication (terminal /FLT)

Terminal /FLT is the indicator for a triggered DESAT or CS event. It is pulled low by an internal FET. The /FLT function is reset by means of a low signal at terminal EN.

3.9.4 Watchdog

The bidirectional signal transmission across the insulation barrier is monitored by watchdogs on the input and output side. These are the most important ones:

- The IGBT is switched off via terminal SOFF and additionally switched off via terminal OFF, if the transmission fails for a given duration.
- A watchdog activates the terminal OFF after typically 5 μs in any case of a soft turn-off event.

3.9.5 I/O signature check

The I/O signature check is a feature that allows the confirmation of switching commands sent by the microcontroller to the driver IC. The SIGO output terminal is an exclusive-or (XOR) combination of the terminals INN, INP, and EN according to Figure 6. The desaturation status on terminal DESAT and the correct voltage at terminal PADP are also monitored.

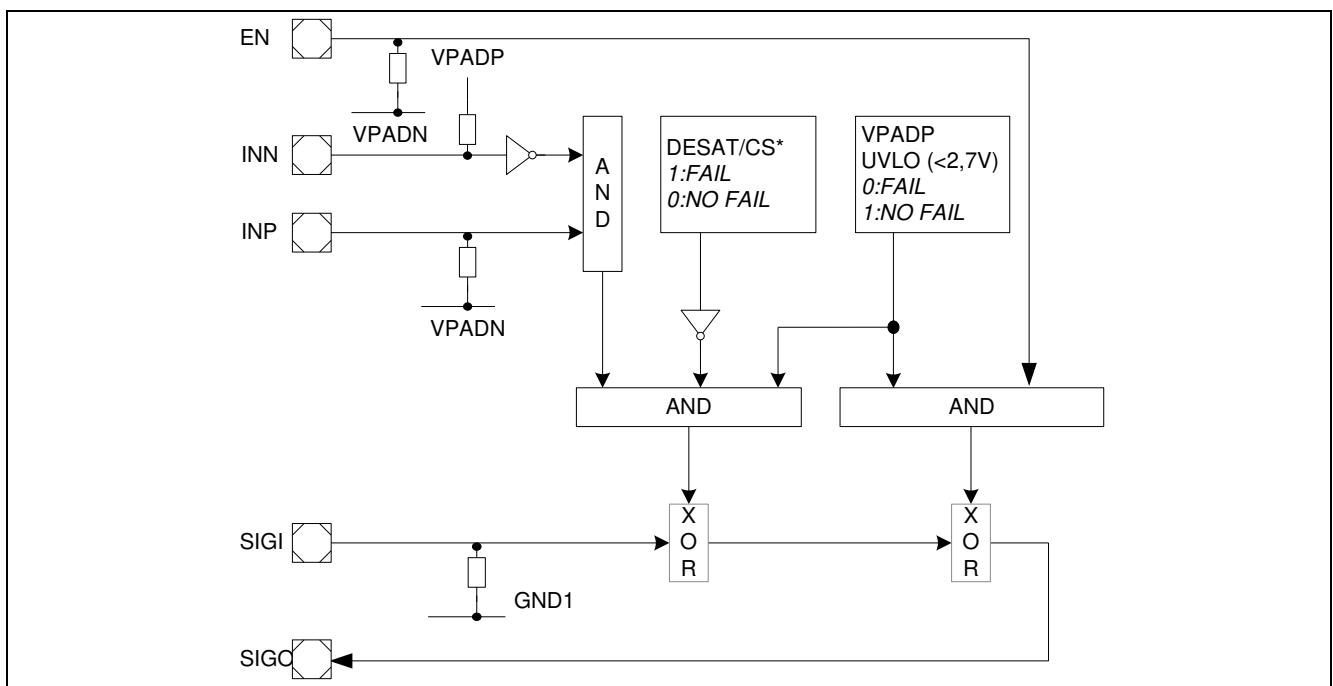

Figure 6 I/O signature check

To save PCB space, the SIGI and SIGO terminals of a series of drivers can be interconnected via a daisy chain. In this case, terminal SIGI of the first driver in the daisy chain should be connected to VCC1 or GND1. Terminal SIGI of the next driver should be connected to terminal SIGO of the previous driver. Terminal SIGO of the last driver in the daisy chain should be connected to the microcontroller.

The I/O signature check does not monitor the status of the IGBT.

Monitored status

- INN / INP and EN
- DESAT
- PADP undervoltage

The reference terminals are VCC1 and GND1.

3.9.6 Two-level turn-off (TLTO)

The TLTO function is activated, if a capacitor is applied between terminal CZ and terminal VEE2. It affects any turn-on and turn-off process, which is either initiated by the input signals INP, INN or EN or by any protection function on the output side. Connecting terminal CZ with terminal VEE2 will deactivate the two-level turn-off function.

The two-level turn-off introduces a second (lower) gate voltage level during the turn-off process according to Figure 15. This additional level ensures lower collector-emitter voltage overshoots during turn-off. The second gate voltage level reduces the collector current of the IGBT when reaching this level. The obtained di_c/dt is therefore slower and generates less induced overvoltage. The required timing, which can be adjusted by the capacitance value at terminal CZ, depends on stray inductance and overcurrent at the beginning of the two-level turn-off period.

Three voltage levels are available:

- The voltage level is set to 11.4 V, if terminal VZ is connected to VEE2,
- the voltage level is set to 10.3 V, if terminal VZ is floating,
- the voltage level is set to 9.3 V, if terminal VZ is connected to VEE2 via a 27 kΩ resistor

The second voltage level is set in a way that turn-off losses are the same as during normal turn-off for nominal current values. The turn-on signal is delayed by the duration of the two-level turn-off in order to achieve identical pulse lengths.

The duration of the plateau is set by the capacitor connected between terminals CZ and VEE2.

The IC starts charging the capacitance on CZ for obtaining the two-level set time T_{TLSET} , when a turn-on signal is given. The IC starts the turn-on sequence and resets the capacitor at terminal CZ as soon as the voltage at terminal CZ exceeds 2.5 V.

The IC activates additionally a soft turn-off sequence, if a turn-off is initiated due to a desaturation condition on terminal DESAT.

3.9.7 Desaturation shut down protection

Desaturation protection ensures the protection of the IGBT in case of a short. When the desaturation voltage on terminal DESAT rises and reaches 9 V, the output is driven low by soft turn-off and the /FLT output terminal is activated. The blanking time is determined by the combination of the highly precise internal current source and an external capacitor. Desaturation protection is only set active at $T_{DESATleb} = 400\text{ns}$ after the preboost phase.

3.9.8 IGBT overcurrent detection

The IGBT overcurrent detection is a protection feature that senses the emitter current on current-sense IGBTs or standard IGBTs via using an emitter shunt resistor. The voltage is measured by a comparator that triggers at 0.35 V. The current sense signal at terminal CS is ignored while the IGBT is off. An external blanking circuit is necessary to prevent false tripping during turn-on. With non-sensing IGBT types, a low resistance shunt is used to sense the emitter current. When a short is detected, the IGBT is switched off by a soft turn-off. Both the desaturation and the current sense features can be used at the same time. This function is therefore not limited to current sensing. It can be used for any shut down condition as well. The fault status is signaled on terminal

/FLT. The fault status has to be reset via terminal EN. IGBT overcurrent detection is only active 400ns after the preboost phase.

3.9.9 Overcurrent protection ON/OFF

The IGBT is switched off via a soft turn-off in case of a CS or DESAT event, if terminal OCOFF is connected to GND2 or left unconnected. If terminal OCOFF is connected to VCC2, the IGBT is not switched off in such cases. However, the signaling of CS or DESAT events to output /FLT is done in any case. The IGBT can be turned off externally instead, e.g. via control input EN.

3.9.10 Soft turn-off

The IGBT can be turned off smoothly via an external higher-ohmic gate resistor attached to terminal SOFF. The soft turn-off speed can be adjusted by selecting the appropriate resistor value. The soft turn-off reduces the voltage overshoot considerably and may be used in combination with the two-level turn-off function of the IC. The regular turn-off function at terminal OFF supports the soft turn-off as soon as the voltage between terminals GATE and VEE2 drops below 3 V. An additional safety feature is installed by means of a watchdog timer, which starts at the same time the soft turn-off is triggered. The watchdog turns off the IGBT in any case via terminal OFF after 5 μ s. If the soft-off function is not used, both the terminals SOFF and OFF can be combined to increase the turn-off current capability of the IC.

Trigger conditions for a soft turn-off:

- Desaturation condition at terminal DESAT
- Overcurrent condition at terminal CS
- Driver Enable OFF (EN equals GND1)
- UVLO1 of the input side supply VCC1
- UVLO of the input side logic reference PADP
- Internal signal transmission error

4 Electrical parameters

4.1 Absolute maximum ratings

Note: Absolute maximum ratings are defined as ratings, which may lead to destruction of the integrated circuit when being exceeded. Unless otherwise noted all parameters refer to GND1 and to $T_A = 25^\circ\text{C}$.

Table 5 Abs. maximum ratings

Parameter	Symbol	Min.	Max.	Unit
Offset voltage $V_{\text{GND1}} - V_{\text{VEE2}}$ 1EDI20I12SV and 1EDU20I12SV only	V_{OFFSET}	-1200	1200	V
Positive power supply input side	V_{VCC1}	-0.3	6.5	
PADP voltage	V_{PADP}	-0.3	16.05	
PADN voltage	V_{PADN}	-0.3	0.3	
Positive power supply output side ¹	V_{VCC2}	-0.3	20.3	
Negative power supply output side ¹	V_{VEE2}	-12	0.3	
Maximum power supply voltage output side ($V_{\text{VCC2}} - V_{\text{VEE2}}$)	V_{max2}	–	28	
Voltage at terminals INN, INP, EN, RDY1, RDY2, /FLT	V_{TERMINAL}	-0.3	V_{PADP}	
Voltage at terminals SIGI, SIGO, SPEED		-0.3	V_{VCC1}	
Voltage at terminal DESAT ¹		-5	V_{VCC2}	
Voltage at terminals OCOFF ¹ , GATE ² , OFF ² , SOFF ²		-0.3	V_{VCC2}	
Voltage at terminal GATE ³		-0.3	5.5	
Voltage at terminals CS ¹ , VZ ² , CZ ² , PRB ²		-0.3	5.5	
Voltage at terminal RSENSE, ON ⁴		-7	V_{VCC2}	
Open drain output current (/FLT, RDY2, RDY1)	I_{OD}	–	10	mA
Output current at terminals SIGO	I_{SIGO}	-6	6	
DC output current at terminal ON ($V_{\text{VCC2}} - V_{\text{VEE2}} = 20\text{ V}$)	$I_{\text{ON,DC}}$	–	10	
Peak output current at terminal OFF ($t_p = 2\ \mu\text{s}$, $f = 20\ \text{kHz}$)	I_{OFF}	–	2.4	A
Peak output current at terminal SOFF ($t_p = 2\ \mu\text{s}$, $f = 20\ \text{kHz}$)	I_{SOFF}	–	1.05	
Junction temperature	T_J	1EDS20I12SV 1EDI20I12SV	125 150	$^\circ\text{C}$
Storage temperature		T_S	-55	125
Total power dissipation ⁵	$P_{\text{D,tot}}$	–	980	mW
Thermal resistance (Both chips active), $T_A = 25\ ^\circ\text{C}$	$R_{\text{th(j-a)}}$	–	102	K/W
Ψ value	$\Psi_{\text{th(j-top)}}$	–	6.69	

¹ with respect to terminal GND2

² with respect to terminal VEE2

³ with respect to terminal OFF

⁴ with respect to terminal VCC2

⁵ Power dissipation is derated linearly with 9.8 mW/ $^\circ\text{C}$ above an ambient temperature of $T_A = 25^\circ\text{C}$. See Figure 17 for reference layouts for these thermal data. Thermal performance may change significantly with layout and heat dissipation of components in close proximity.

Table 5 Abs. maximum ratings

Parameter		Symbol	Min.	Max.	Unit
ESD Capability	HBM ¹	V_{ESD}	–	750	V
	CDM ²			1000	
Common mode transient immunity		$ dV_{ISO}/dt $	–	50	kV/ μ s

4.2 Operating range

Note: The IC operates as described in the functional description within the operating range. Unless otherwise noted all parameters refer to terminal GND1 and $T_A = 25^\circ\text{C}$.

Table 6 Operating parameters

Parameter	Symbol	Min.	Typ.	Max.	Unit
Positive power supply input side	V_{VCC1}	4.85	5	5.5	V
Input side logic reference voltage ranges $V_{PADP} - V_{PADN}$	ΔV_{PAD}	3	3.3	5.5	
		7	15	15.75	
Control voltage by terminal SPEED at terminal RSENSE	$V_{IN,RSENSE}$	$V_{VCC2} - 1.7$	–	$V_{VCC2} - 0.2\text{V}$	
Voltage at terminal SPEED ³	V_{SPEED}	0	–	3.3	
Positive power supply output side ⁴	V_{VCC2}	0	15	20	
Negative power supply output side ⁴	V_{VEE2}	-12	-8	0	
Power supply voltage output side ($V_{VCC2} - V_{VEE2}$)	V_{max2}	–	–	25	
Output current at terminal SIGO	I_{SIGO}	-3	–	3	mA
Ambient temperature	T_A	-40	–	105	$^\circ\text{C}$

¹ According to EIA/JESD22-A114-B

² According to EIA/JESD22-C101

³ With respect to voltage V_{PADN}

⁴ With respect to voltage V_{GND2}

4.3 Electrical characteristics

Note: The electrical characteristics given below include the spread of values for the junction temperature range of $-40^{\circ}\text{C} \leq T_j \leq 125^{\circ}\text{C}$. All values refer to the supply condition of $V_{VCC1} = V_{PADP} = 5\text{ V}$, $V_{PADN} = V_{GND1} = 0\text{ V}$, $V_{VCC2} = 15\text{ V}$, $V_{VEE2} = -8\text{ V}$ and the given test conditions. Typical values represent the median values at $T_A = 25^{\circ}\text{C}$ under the above mentioned supply conditions. Unless otherwise noted all voltages are given with respect to their respective reference terminal (GND1 for terminals 19 to 36, GND2 for terminals 1 to 18).

4.3.1 Voltage supply

Table 7 Voltage supply

Parameter	Symbol	Values			Unit	Test condition
		Min.	Typ.	Max.		
UVLO threshold for VCC1	power up	V_{UVLOH1}	–	4.63	4.85	V
	power down	V_{UVLOL1}	3.5	4.47	–	
UVLO hysteresis VCC1 ($V_{UVLOH1} - V_{UVLOL1}$)	$V_{UVLO1,hys}$	0.08	–	–		
UVLO threshold VCC2	power up	V_{UVLOH2}	–	11.9	12.6	
	power down	V_{UVLOL2}	10.4	11.0	–	
UVLO hysteresis VCC2 ($V_{UVLOH2} - V_{UVLOL2}$)	$V_{UV,hys2}$	0.3	–	–		
UVLO threshold for PADP	power up	V_{UVLOH3}	–	–	2.95	
	power down	V_{UVLOL3}	1.6	–	–	
Quiescent current input side VCC1	I_{Q1}	–	9.6	13	mA	$V_{INP} = V_{PADP}$, $V_{INN} = V_{PADN}$ $V_{RDY1} = V_{RDY2} = V_{FLT} = V_{PADP}$
Quiescent current input side VCC1		–	9.6	13		$V_{INP} = V_{PADP} = 15\text{ V}$ $V_{FLT} = V_{RDY1} = V_{RDY2} = 5\text{ V}$, $V_{INN} = V_{PADN}$
Quiescent current output side VCC2	I_{Q2}	–	7.3	9.5		$V_{INP} = V_{PADP}$, $V_{INN} = V_{PADN}$ $V_{RDY1} = V_{RDY2} = V_{FLT} = V_{PADP}$
Quiescent current output side in UVLO mode	$I_{Q2,UVLO}$	–	4.5	6		$V_{VCC2} = 10.4\text{ V}$
Quiescent current output side VEE2	I_{Q3}	–	4.7	–		$V_{INP} = V_{PADP}$, $V_{INN} = V_{PADN}$ $V_{RDY1} = V_{RDY2} = V_{FLT} = V_{PADP}$
Quiescent current PADP	I_{Q4}	–	1	–		$V_{INP} = V_{PADP}$, $V_{INN} = V_{PADN}$ $V_{RDY1} = V_{RDY2} = 5\text{ V}$ $V_{FLT} = 5\text{ V}$

4.3.2 Logic input and output

Table 8 Logic input and output

Parameter	Symbol	Values			Unit	Test condition
		Min.	Typ.	Max.		
Low level input voltage terminals INP, INN, EN	V_{IL}	1.5	–	–	V	
High level input voltage terminals INP, INN, EN	V_{IH}	–	–	3.5		
Low level input voltage terminal SIGI	$V_{IL,SIGI}$	1.5	–	–		
High level input voltage terminal SIGI	$V_{IH,SIGI}$	–	–	3.5		
Low level output voltage terminal SIGO	$V_{OL,SIGO}$	V_{GND1}	0.1	0.3		$I_{IL,SIGO} = 3 \text{ mA}$
High level output voltage terminal SIGO	$V_{OH,SIGO}$	4.3	4.7	V_{VCC1}		$I_{IH,SIGO} = -3 \text{ mA}$
Low level output voltage terminal /FLT	$V_{OL,FLT}$	–	0.08	0.3		$I_{IL,pin} = 3 \text{ mA}$
Low level output voltage terminals RDY1, RDY2	$V_{OL,RDY1}$, $V_{OL,RDY2}$	–	0.1	0.3		$I_{IL,pin} = 3 \text{ mA}$
Input bias current INP	$I_{IH,INP}$	30	60	100	μA	$V_{INP} = 5 \text{ V}$
Input bias current EN	$I_{IH,EN}$	30	60	100		$V_{EN} = 5 \text{ V}$
Input bias current INN	$I_{IL,INN}$	-1200	-700	-350		$V_{INN} = 0\text{V}$
Input bias current SPEED	$I_{IH,SPEED}$	6	10	16		$V_{SPEED} = 5 \text{ V}$
Input filter time terminals INP, INN, SIGI	T_{FILIN}	22	–	–	ns	$V_{TERMINAL} = 5 \text{ V}$
Input filter time terminal EN	T_{FILEN}	45	–	–		$V_{EN} = 5 \text{ V}$
Fault reset duration terminal EN	$T_{EN,RST}$	870	–	–		$V_{EN} = 0\text{V}, V_{VEE2}=0\text{V}$
Propagation delay EN to ON (Turn-On)	$T_{EN,ON}$	–	530	–		
Shut down propagation delay EN to SOFF (Turn-Off)	$T_{EN,SOFF}$	–	530	680		$V_{VEE2} = 0 \text{ V}$

4.3.3 Gate driver

Table 9 Gate driver

Parameter	Symbol	Values			Unit	Test condition
		Min.	Typ.	Max.		
Voltage of sense resistor for gate current level 1	V_{RSNSE}	V_{VCC2} - 0.165	V_{VCC2} - 0.197	V_{VCC2} - 0.230	V	$V_{SPEED} = 3.3 \text{ V}$
Voltage of sense resistor for gate current level 2		V_{VCC2} - 0.250	V_{VCC2} - 0.287	V_{VCC2} - 0.324		$V_{SPEED} = 2.91 \text{ V}$
Voltage of sense resistor for gate current level 3		V_{VCC2} - 0.340	V_{VCC2} - 0.376	V_{VCC2} - 0.413		$V_{SPEED} = 2.63 \text{ V}$
Voltage of sense resistor for gate current level 4 ¹		V_{VCC2} - 0.420	V_{VCC2} - 0.466	V_{VCC2} - 0.512		$V_{SPEED} = 2.35 \text{ V}$
Voltage of sense resistor for gate current level 5		V_{VCC2} - 0.510	V_{VCC2} - 0.556	V_{VCC2} - 0.601		$V_{SPEED} = 2.08 \text{ V}$

¹ Default state after power on ($V_{VCC1} > V_{UVLOH1}$)

Voltage of sense resistor for gate current level 6	V _{RSENSE}	V _{VCC2-}	V _{VCC2-}	V _{VCC2-}	V	V _{SPEED} = 1.80 V
Voltage of sense resistor for gate current level 7		0.600	0.645	0.691		V _{SPEED} = 1.52 V
Voltage of sense resistor for gate current level 8		0.680	0.735	0.790		V _{SPEED} = 1.25 V
Voltage of sense resistor for gate current level 9		0.770	0.825	0.880		V _{SPEED} = 0.97 V
Voltage of sense resistor for gate current level 10		0.825	0.912	0.999		V _{SPEED} = 0.69 V
Voltage of sense resistor for gate current level 11		0.910	1.003	1.095		V _{SPEED} = 0 V
V _{SPEED} hysteresis	V _{SPEED,hys}	–	–	60	mV	
Low level output voltage terminal OFF	V _{OFFL}	–	V _{VEE2}	V _{VEE2+}	V	I _{OFFL} = 20 mA
		–	+0.03	0.09		I _{OFFL} = 200 mA
		–	V _{VEE2}	V _{VEE2+}		I _{OFFL} = 1 A
		–	+0.3	0.85		I _{OFFL} = 2 A ¹
Low level output voltage terminal SOFF	V _{SOFFL}	–	V _{VEE2}	V _{VEE2+}	V	I _{SOFFL} = 20 mA
		–	+0.06	0.18		I _{SOFFL} = 200 mA
		–	V _{VEE2}	V _{VEE2+}		I _{SOFFL} = 500 mA
		–	+0.6	1.7		I _{SOFFL} = 1 A ¹
Turn-on clamping voltage terminal ON	V _{ON,ON}	–	V _{VCC2-}	V _{VCC2-}	V	
		–	6.5	5.0		
Turn-off threshold voltage terminal GATE ²	V _{GATE,th}	–	3	–		
Active Shut Down Voltage (VCC2 open)	V _{ACTSD}	–	1.4	2.4		I _{OFF} = 200 mA, V _{VEE2} = 0 V,
Output current of terminal ON	I _{ON+}	50	–	–	mA	t _p = 2 μs
Output current of terminal ON	I _{ON-}	–	–	-50		
Preboost time	T _{PRB}	–	135	180	ns	
Speed setting propagation delay ¹	T _{SPEED}	–	–	120	μs	IGBT is turn on
Fall time ¹	T _{FALL}	–	8	–	ns	C _{LOAD} = 1 nF
Turn-on propagation delay without PMOS	T _{PDON}	–	500	540		T _A = 25°C, V _{VEE2} = 0V
Turn-on propagation delay over junction temperature ¹	T _{PDONt}	–	–	570		V _{VEE2} = 0V
Turn-off propagation delay	T _{PDOFF}	–	485	535		T _A = 25°C, V _{VEE2} = 0V
Turn-off propagation delay over junction temperature ¹	T _{PDOFFt}	–	–	565		V _{VEE2} = 0 V
Matching delay (T _{PDON} - T _{PDOFF})	MT	–	15	30		V _{VEE2} = 0 V

¹ The Parameter is not subject to production test - verified by design / characterization

² Reference to V_{VEE2}

4.3.4 Desaturation protection

Table 10 Desaturation protection

Parameter	Symbol	Values			Unit	Test condition
		Min.	Typ.	Max.		
Desaturation trigger level	V_{DESAT}	8.4	9	9.4	V	
Blanking capacitor charge current	$I_{DESAT,C}$	450	500	550	μA	$V_{DESAT} = 2 V$
Blanking capacitor discharge current	$I_{DESAT,D}$	–	12.5	–	mA	$V_{DESAT} = 6 V$
Desaturation leading edge blanking time ¹	$T_{DESATleb}$	–	400	–	ns	
Desaturation filter time ¹	$T_{DESATFIL}$	–	230	–		
DESAT to /FLT propagation delay	$T_{DESATFLT}$	–	760	995		$V_{VEE2} = 0 V$
DESAT shut down propagation delay to SOFF	T_{SOFF}	–	360	540		$V_{VEE2} = 0 V$
DESAT shut down watch dog	$T_{DESATOFF}$	–	5.2	8	μs	OCOFF = low, $V_{VEE2} = 0 V$

4.3.5 Overcurrent protection disable

Table 11 Overcurrent protection disable

Parameter	Symbol	Values			Unit	Test condition
		Min.	Typ.	Max.		
High level input voltage terminal OCOFF	$V_{IH,OCOFF}$	11.4	12.5	13	V	
Low level input voltage terminal OCOFF	$V_{IL,OCOFF}$	7	7.5	8.2		
Input bias current OCOFF	$I_{IH,OCOFF}$	–	150	250	μA	$V_{OCOFF} = 15 V$

4.3.6 Current sense

Table 12 Current sense

Parameter	Symbol	Values			Unit	Test condition
		Min.	Typ.	Max.		
Current sense trigger threshold	V_{CS}	320	350	380	mV	$V_{SOFF} < 5 V$
Input bias current CS	$I_{IH,CS}$	-200	-125	-45	μA	$V_{CS} = 0 V$
Over current detection blanking time ¹	$T_{CS,blank}$	–	420	–	ns	
Shut down propagation delay CS to SOFF ¹	T_{CS}	–	280	540		
Propagation delay CS to /FLT ¹	$T_{CS,FLT}$	–	760	995		

¹ The Parameter is not subject to production test

4.3.7 Two-level turn-off

Table 13 Two-level turn-off

Parameter	Symbol	Values			Unit	Test condition
		Min.	Typ.	Max.		
Two-level voltage terminal VZ	V_{TLTO}	10.7	11.4	12.1	V	Terminal VZ connected to VEE2
		9.6	10.3	11.0		VZ open
		8.6	9.3	10.0		$R_{VZ} = 27\text{ k}\Omega$
Two-level turn-off threshold voltage ¹	$V_{TLTO,th}$	–	2.5	–		
Two-level turn-off charging current	I_{CZ}	-1150	-950	-750	μA	$V_{CZ} = V_{EE2} + 1\text{V}$
Two-level turn-off time limitation	T_{TLLIM}	3	5	7	μs	$V_{VEE2} = 0\text{ V}$
Two-level voltage slope ²	dV_{TLTO}/dt	–	20	–	$\text{V}/\mu\text{s}$	$C_{LOAD} = 10\text{ nF}$

¹ Referenced to V_{VEE2}

² The parameter is not subject to production test - verified by design / characterization

5 Insulation characteristics

Insulation characteristics are guaranteed only within the safety maximum ratings which must be ensured by protective circuits in application. Surface mount classification is class A in accordance with CECC00802.

Table 14 Insulation characteristics

Parameter	Symbol	Characteristic	Unit
Installation classification per EN 60664-1, Table 1		Overvoltage categories	
For rated mains voltage $\leq 150 V_{rms}$		I-IV	
For rated mains voltage $\leq 300 V_{rms}$		I-IV	
For rated mains voltage $\leq 600 V_{rms}$		I-III	
For rated mains voltage $\leq 1000 V_{rms}$		I-II	
Climatic Classification according to IEC 68		40 / 105 / 21	
Pollution degree (EN 60664-1)		2	
Minimum external clearance	<i>CLR</i>	8.5	mm
Minimum external creepage	<i>CPG</i>	8.5	
Minimum Comparative Tracking Index	<i>CTI</i>	>400	

5.1 Tested according to VDE 0884-10 (Standard expired on Dec. 31, 2019, 1EDS20I12SV only)

While the standard has expired on Dec. 31, 2019, the 100% testing is continued although there is no continued quarterly monitoring.

Table 15 Tested for reinforced isolation limits according to VDE 0884-10 (Standard expired on Dec. 31, 2019, 1EDS20I12SV only)

Parameter	Symbol	Characteristic	Unit
Maximum Repetitive Insulation Voltage	V_{IORM}	1420	V
Input to output test voltage, method b	$V_{pd(m)}$	2662	(peak)
$V_{pd(m)} = V_{IORM} * 1.875$, productive test, $t_m = 1$ sec, Partial discharge < 5 pC			
Highest allowable overvoltage	V_{IOTM}	8000	
Maximum Surge Isolation Voltage	V_{IOSM}	>6000	
Insulation resistance at T_s , $V_{IO} = 500$ V	R_{IO}	$> 10^9$	Ω

Notes

This coupler is suitable-only within the safety ratings. Compliance with the safety ratings shall be ensured by means of suitable protective circuits.

5.2 Recognized under UL 1577 (File E311313, 1EDS20I12SV and 1EDU20I12SV only)

Table 16 Recognized under UL 1577

Parameter	Symbol	Characteristic	Unit
Insulation withstand voltage / 1 min	V_{ISO}	5000	V (rms)
Insulation test voltage / 1 s	V_{ISO}	≥ 6000	V (rms)

6 Timing diagrams

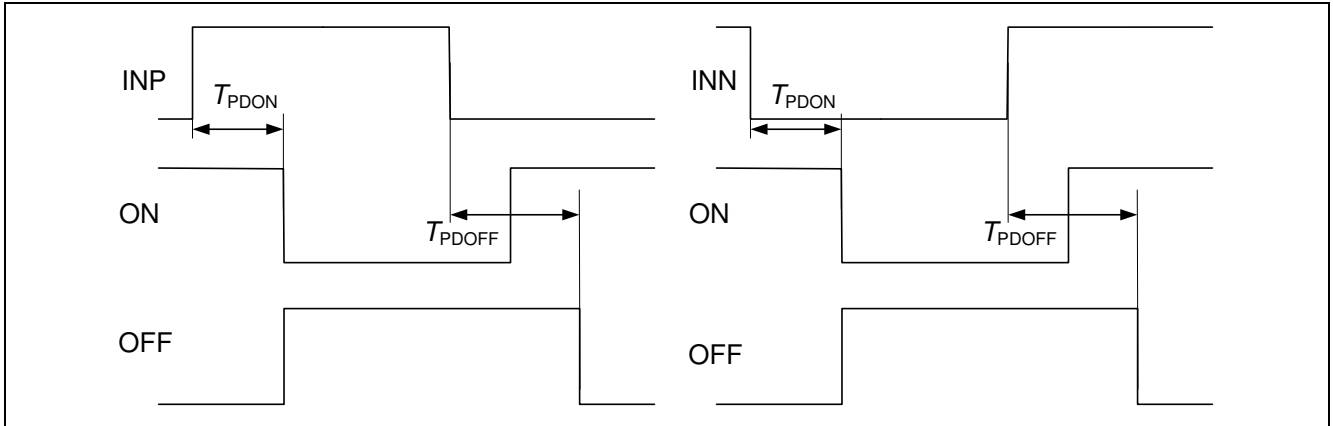

Figure 7 Timing of turn-on and turn-off propagation delay without two-level turn-off mode

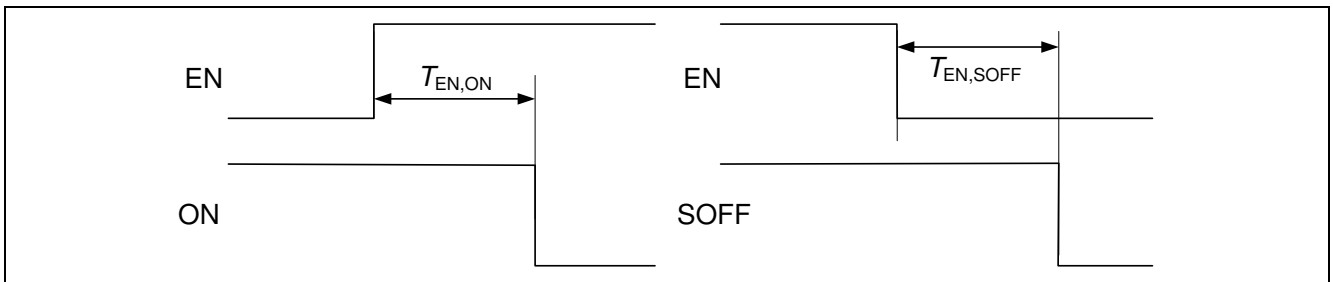

Figure 8 Timing of EN turn-on and shut down propagation delay



Figure 9 Timing of short pulse suppression terminal INP and SIGI ($T_P < T_{FILIN}$)

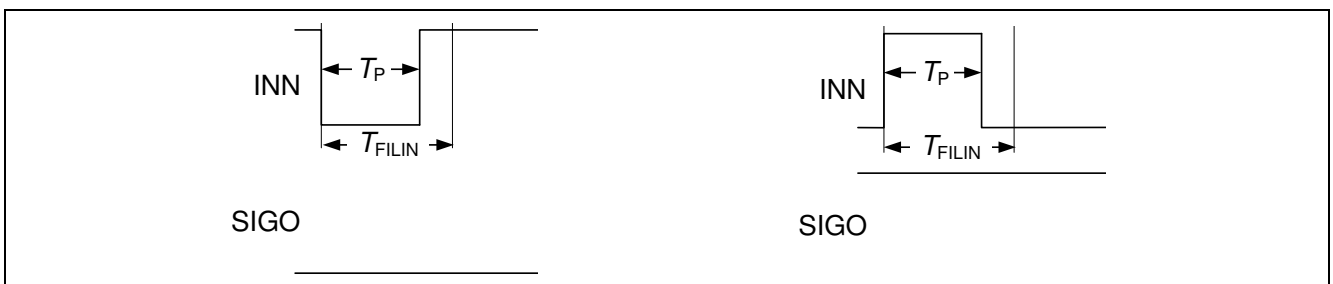

Figure 10 Timing of short pulse suppression terminal INN ($T_P < T_{FILIN}$)

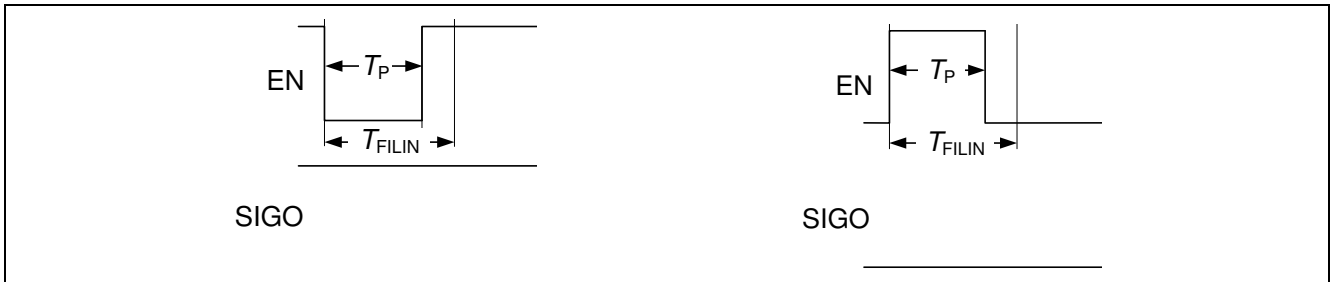

Figure 11 Timing of short pulse suppression terminal EN ($T_P < T_{FILIN}$)

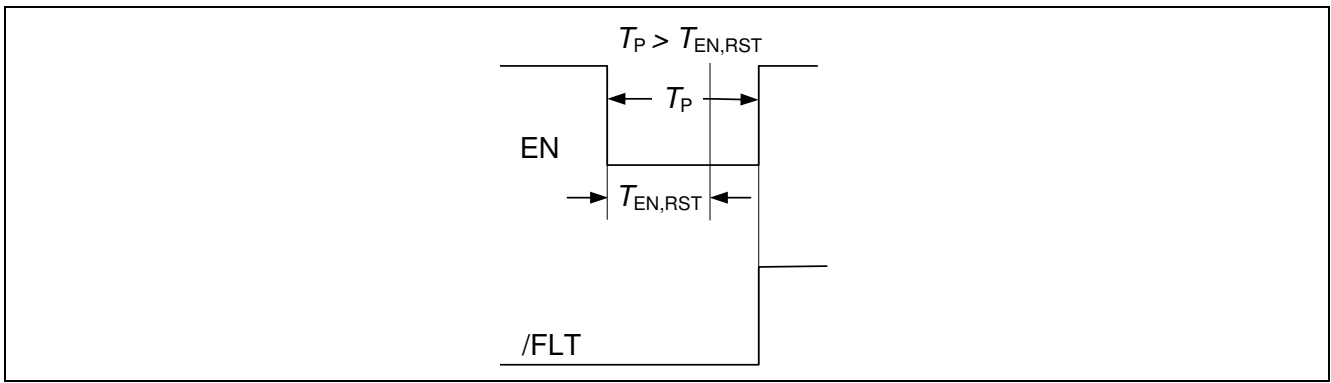

Figure 12 Timing for fault reset at terminal EN

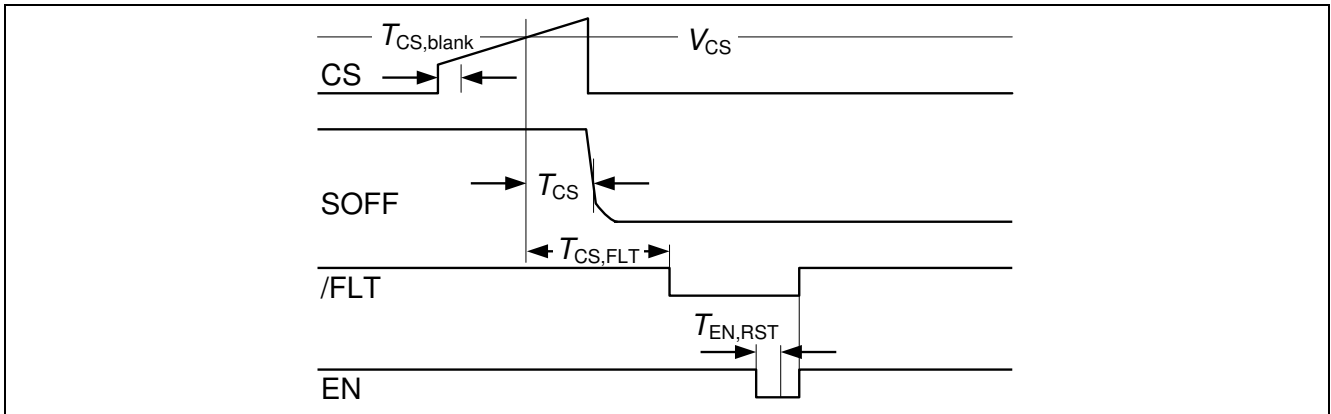

Figure 13 Timing of CS events incl. terminals SOFF, /FLT and EN

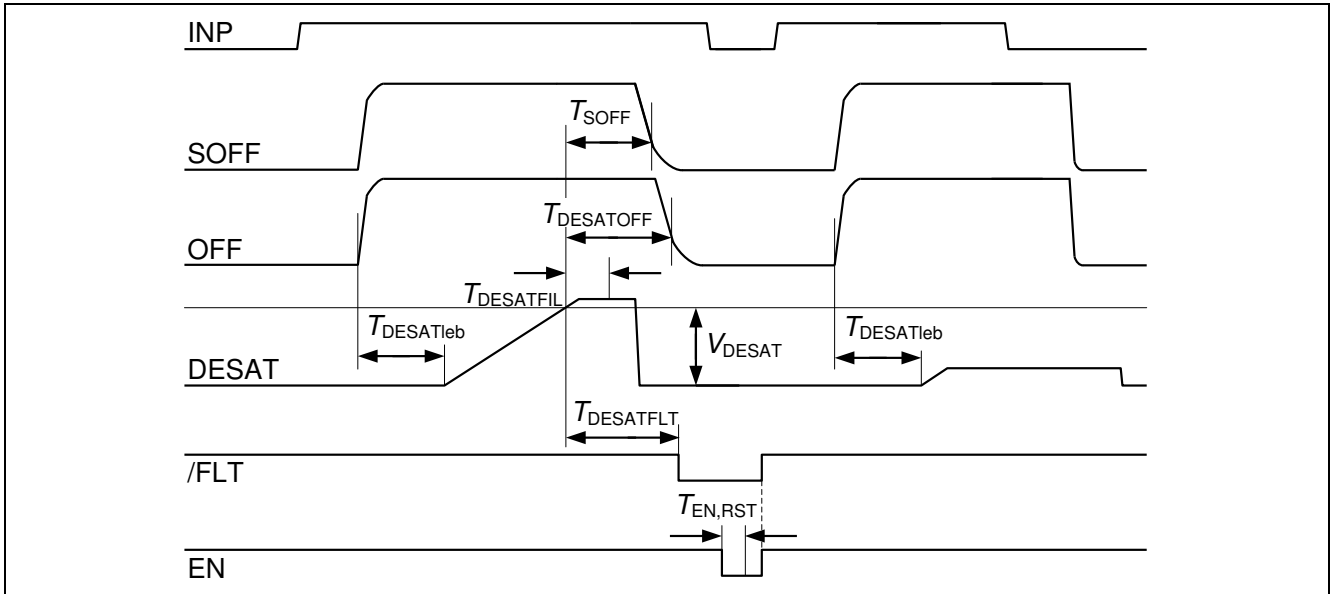

Figure 14 Timing for DESAT events incl. terminals SOFF, /FLT and EN (timing is same for related INN input signal)

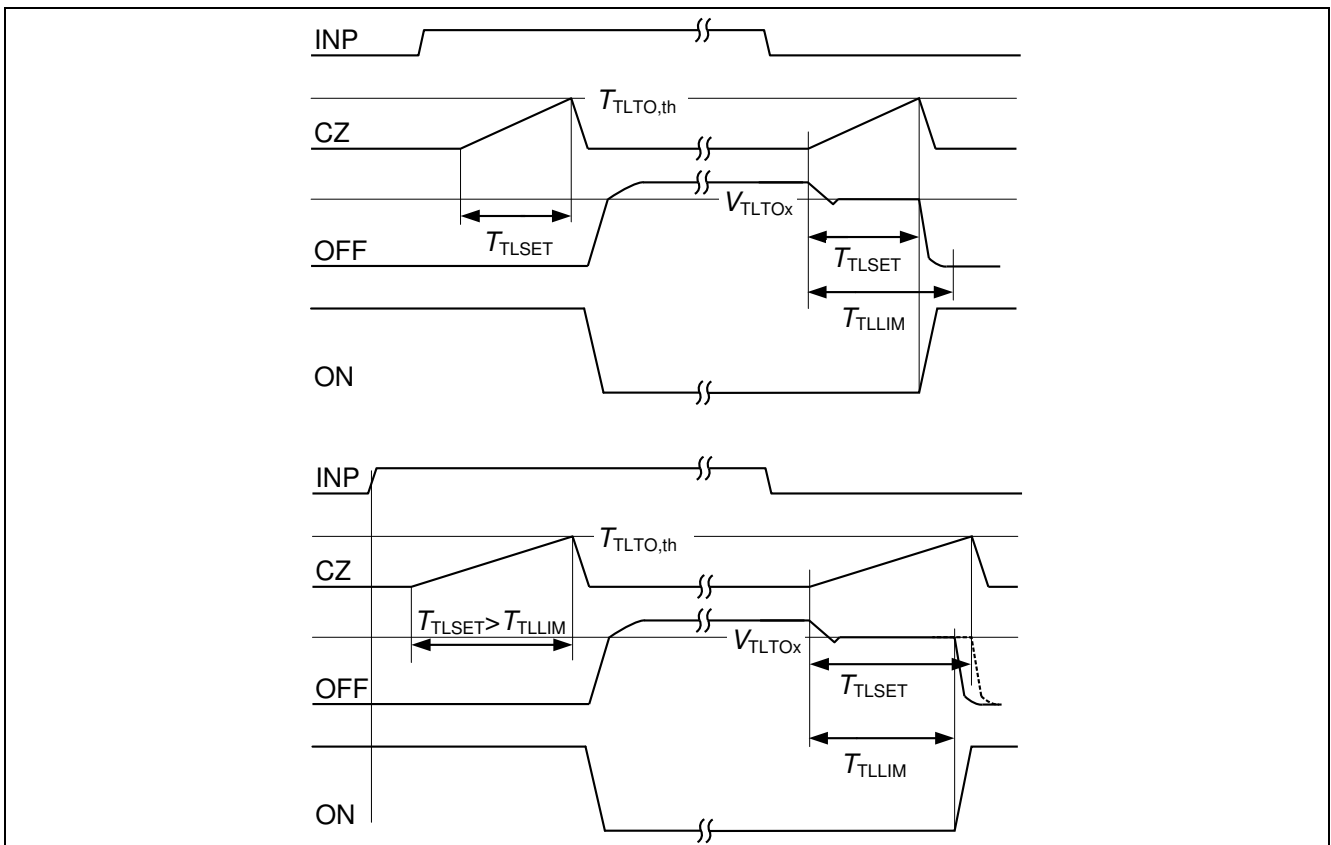

Figure 15 Timing for two-level turn-off incl. terminals CZ and OFF
(top: $T_{\text{TLSET}} < T_{\text{TLLIM}}$, bottom: $T_{\text{TLSET}} > T_{\text{TLLIM}}$)

7 Package

7.1 PG-DSO-36-64

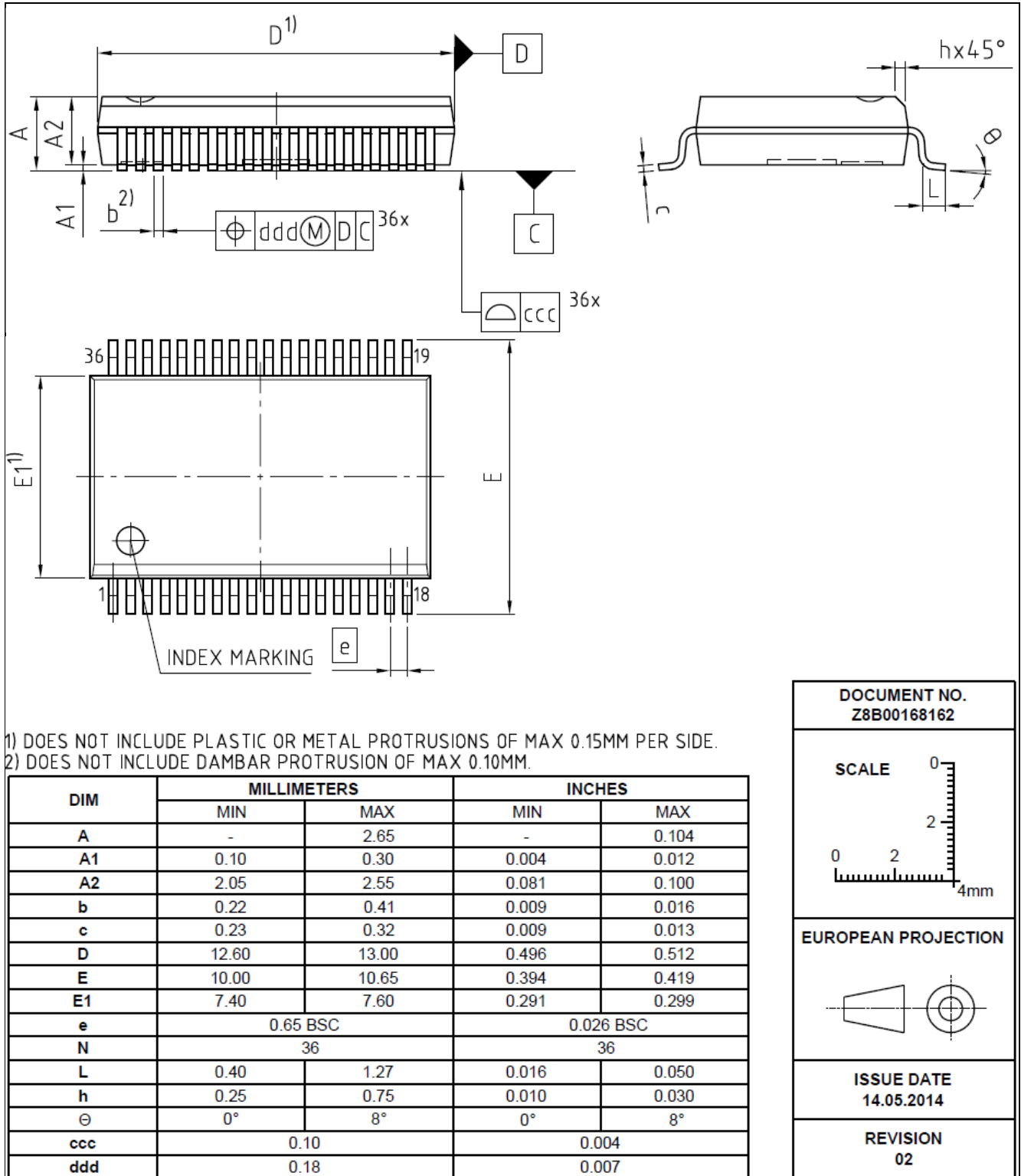

Figure 16 Package drawing

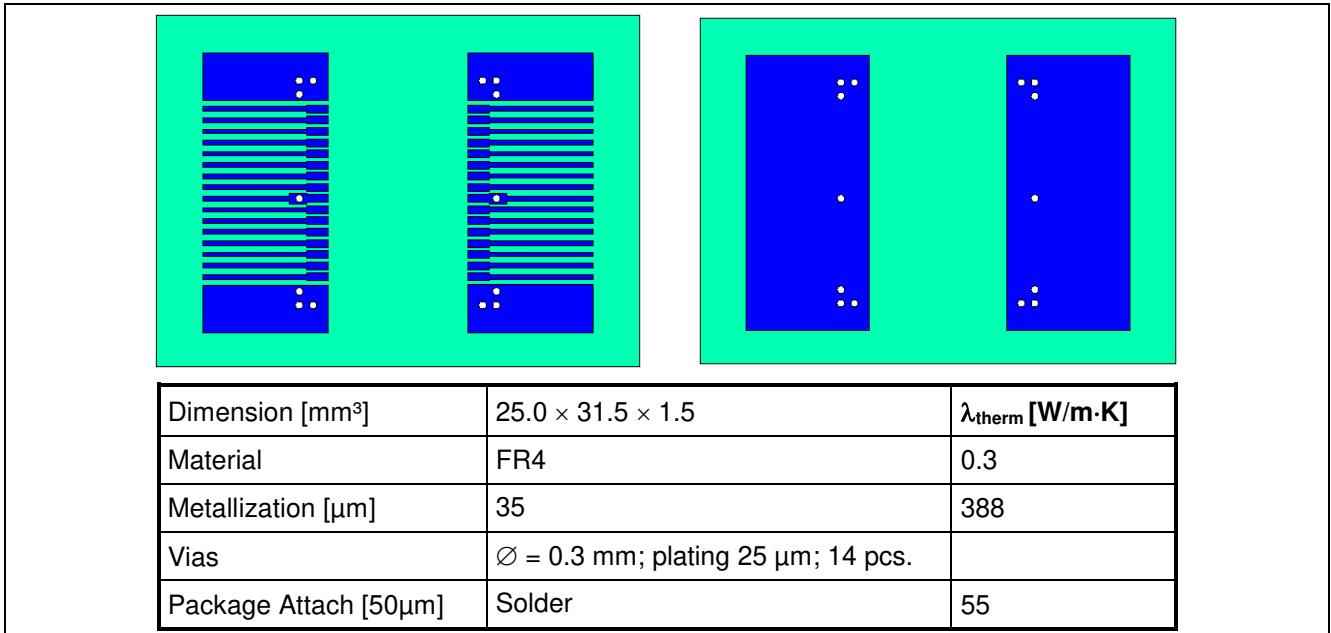

Figure 17 PCB reference layout (left: top layer, right: bottom layer)

Thermal performance may change significantly with layout and heat dissipation of components in close proximity.

www.infineon.com

Published by Infineon Technologies AG