

B202000N2**

SERIES _____
 B20= FORM A BASE SERIES
 POLES _____
 2= 2 POLE & 3= 3 POLE
 CURVED BASE DIAMETER _____
 000 = FLAT
 MATERIAL AND HOUSING COLOR _____
 G= PA6 GRAY, N= PA6 BLACK, W= PA6 BLACK V0
 GASKET & SCREWS _____
 1= NBR INTEGRATED GASKET & SCREWS
 2= NBR FLAT GASKET & SCREWS
 4= SILICON FLAT GASKET & SCREWS
 0= WITHOUT GASKET AND SCREWS
 ADDITIONAL INFORMATION _____
 UR= UL APPROVED
 SA= UL LISTED

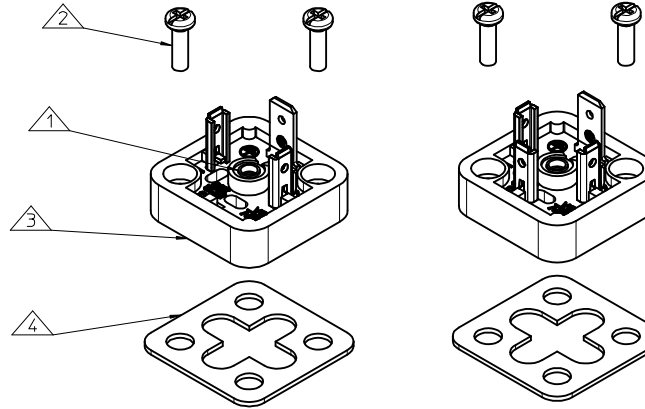

B202 SERIES BASE

B203 SERIES BASE

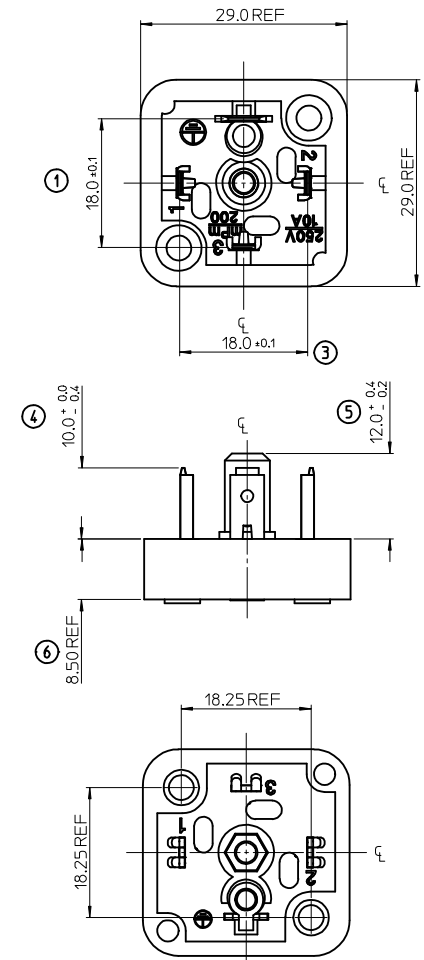

NOTES

- FOR SPECIFIC PART NUMBERS PLEASE CONTACT SALES OR CONSULT THE INTELLIGENT PART NUMBERS IN THE TABLE ATTACHED
- PRODUCT SPEC: SEE PS-121201-001
- PACKAGING SPEC: SEE PK-121012-B20

LAST INSPECTION NUMBER USED 5

Part No	MPM Part No	DESCRIPTION	BEND ANGLE
1210120013	B202000N2	PLATTE 2+ERDE 2-DIAGONAL	180°
1210120161	B202000G2	BAS QUAD.202 GRIGIA 2P+T	180°
1210120168	B202000W2SA	BAS202 NERA UL94 V0 UL LISTED	180°
1210120169	B203000W2SA	BAS203 NERA UL94 V0 UL	180°
1210120019	B203000N2	STD. BASE 3 POLE+EARTH FLAT	180°

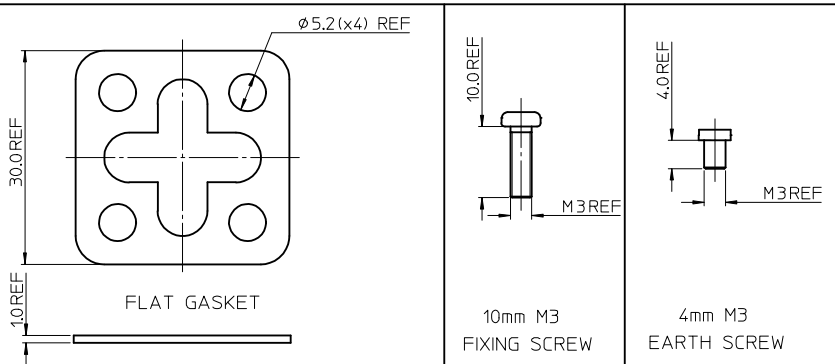

ITEM	DESCRIPTION
1	CENTRE SCREW
2	FIXING SCREWS
3	BASE
4	GASKET

ADDED PART NUMBER	DESCRIPTION	QUALITY SYMBOLS		GENERAL TOLERANCES (UNLESS SPECIFIED)		DIMENSION STYLE		SCALE	DESIGN UNITS	THIRD ANGLE PROJECTION
		mm	INCH	mm	INCH	MM ONLY	1:1	METRIC	THIRD ANGLE PROJECTION	
IPG2014-053Z	2013/09/17	4 PLACES	± ---	± ---	± ---	MM ONLY	1:1	METRIC	THIRD ANGLE PROJECTION	B20 SERIES BASES
DRWN:KORNOYLE	2013-10-23	3 PLACES	± ---	± ---	± ---	DRAWN BY	DATE	TITLE		
CHKD:OSHEA	2013-10-23	2 PLACES	± 0.10	± ---	± ---	DMAHER_WEU	2010/03/18			
APPR:STGR/FFIN	2013/11/11	1 PLACE	± 0.20	± ---	± ---	CHECKED BY	DATE			
		ANGULAR ± 2°		DRAFT WHERE APPLICABLE MUST REMAIN WITHIN DIMENSIONS		APPROVED BY	DATE	Molex		MOLEX INCORPORATED
		SEE TABLE		MATERIAL NO.		JWALLACE	2010/03/24	DOCUMENT NO.		SD-121012-013
		SIZE A2		THIS DRAWING CONTAINS INFORMATION THAT IS PROPRIETARY TO MOLEX INCORPORATED AND SHOULD NOT BE USED WITHOUT WRITTEN PERMISSION						SHEET NO. 1 OF 1