

LCD-CM2B

Dual Small Flat Panel Ceiling Mount Adaptor

Product Features:

Adapts an LCD-1CB to accommodate two flat panels

Holds 10" – 23" flat panels

Accommodates flat panels with 75 or 100mm
VESA hole patterns

Adjustable -5° to +30° tilt /Rotates 240° (panel)

LCD-CM2B and LCD-1CB combined load capacity - 50 lbs

Black powder coat finish

Product Specifications:

(for Architects & Engineers)

The adaptor which will allow two ceiling mounted flat panels shall be the Video Mount Products (VMP) model LCD-CM2B. The adaptor shall be used with one LCD-1CB to mount LCD displays to the ceiling or other suitable support surface. The adaptor shall be constructed primarily of formed steel and shall incorporate nylon filled nuts and arc welds. The load capacity of the combined LCD-CM2B and LCD-1CB shall be 50 lbs.

Video Mount Products

345 Log Canoe Circle

Stevensville, MD 21666

Toll Free: 877.281.2169

Telephone: 410.643.6390

Facsimile: 410.643.6615

www.videomount.com



* LCD-CM2B shown assembled with LCD-1CB (not included)

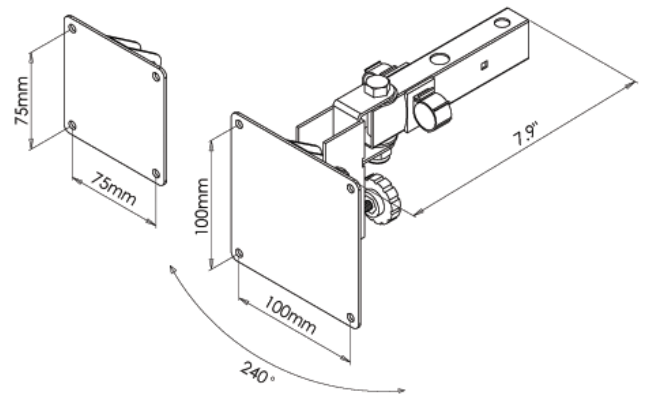

VMP
VIDEO MOUNT PRODUCTS