

DIODE MODULE (F.R.D.)

FDF25CA100/120

UL;E76102(M)

Power Diode Module **FDF25CA** is designed for single phase full wave rectification, which has four fast recovery diodes connected in a single phase bridge configuration. **FDF25CA** is suitable for high frequency application requiring low loss and high speed control.

- High Speed $t_{rr} \leq 200\text{ns}$
- $I_D = 25\text{A}$
- Isolated mounting construction.
- High Surge Capability

(Applications)

Switching Power Supply, Inverter Welding Power Supply
Power Supply for Telecommunication

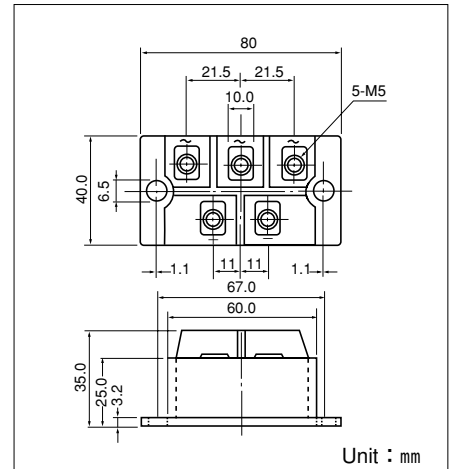
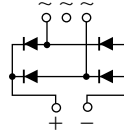

Maximum Ratings

($T_j = 25^\circ\text{C}$ unless otherwise specified)

Symbol	Item	Ratings		Unit
		FDF25CA100	FDF25CA120	
V_{RRM}	Repetitive Peak Reverse Voltage	1000	1200	V
$V_{R(DC)}$	D.C. Reverse Voltage	800	960	V

Symbol	Item	Conditions	Ratings	Unit	
I_D	Output Current (D.C.)	D.C. current. $T_c : 114^\circ\text{C}$	25	A	
I_{FSM}	Surge Forward Current	$\frac{1}{2}$ cycle, 60Hz, peak value, non-repetitive	400	A	
I_t^2	I_t^2	Value for one cycle of surge current	660	A^2S	
T_j	Operating Junction Temperature		-40 to +150	$^\circ\text{C}$	
T_{stg}	Storage Temperature		-40 to +125	$^\circ\text{C}$	
V_{ISO}	Isolation Breakdown Voltage (R.M.S.)	A.C. 1 minute	2500	V	
	Mounting Torque	Muonting(M6)	Recommended Value 2.5-3.9 (25-40)	4.7 (48)	N·m (kgf·cm)
		Terminal (M5)	Recommended Value 1.5-2.5 (15-25)	2.7 (28)	
	Mass	Typical Value	200	g	

Electrical Characteristics

Symbol	Item	Conditions	Ratings			Unit
			Min.	Typ.	Max.	
I_{RRM}	Repetitive Peak Reverse Current	$V_R = V_{RRM}, T_j = 150^\circ\text{C}$			2.0	mA
V_{FM}	Forward Voltage Drop	$I_F = 25\text{A}$, Inst. measurement			1.8	V
t_{rr}	Reverse Recovery Time, (Max.)	$I_F = 25\text{A}, -di/dt = 100\text{A}/\mu\text{s}$			200	ns
$R_{th(j-c)}$	Thermal Impedance	Junction to case			0.4	$^\circ\text{C}/\text{W}$

Forward Characteristics

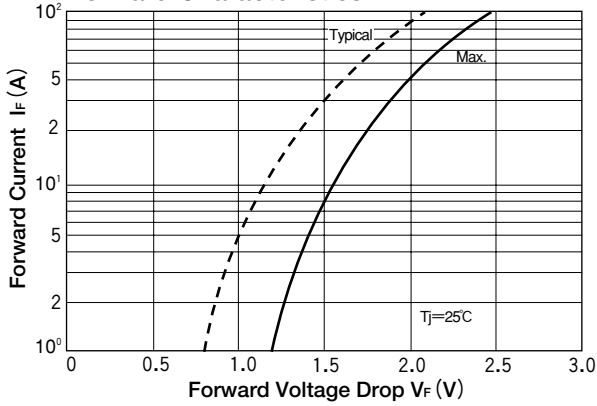

Reverse Recovery Characteristics

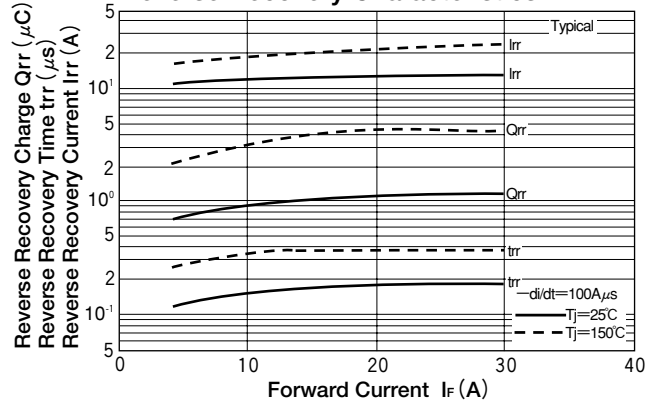

Transient Thermal Impedance

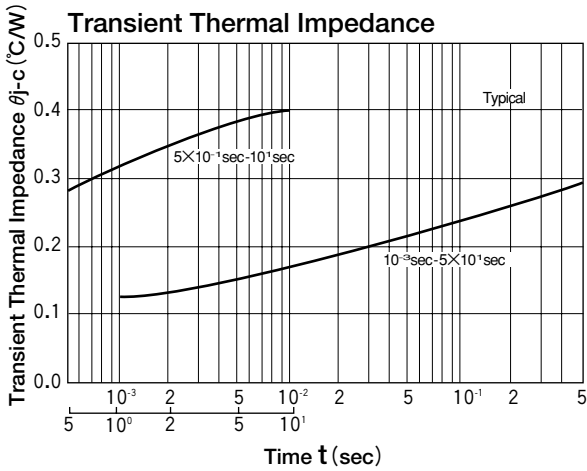

Reverse Recovery Characteristics

