

REVISONS		DATE	OWN	APVD
LOC	DIST	DESCRIPTION		
D		REV PER CEO-07-019089	14SEP07	PY DE

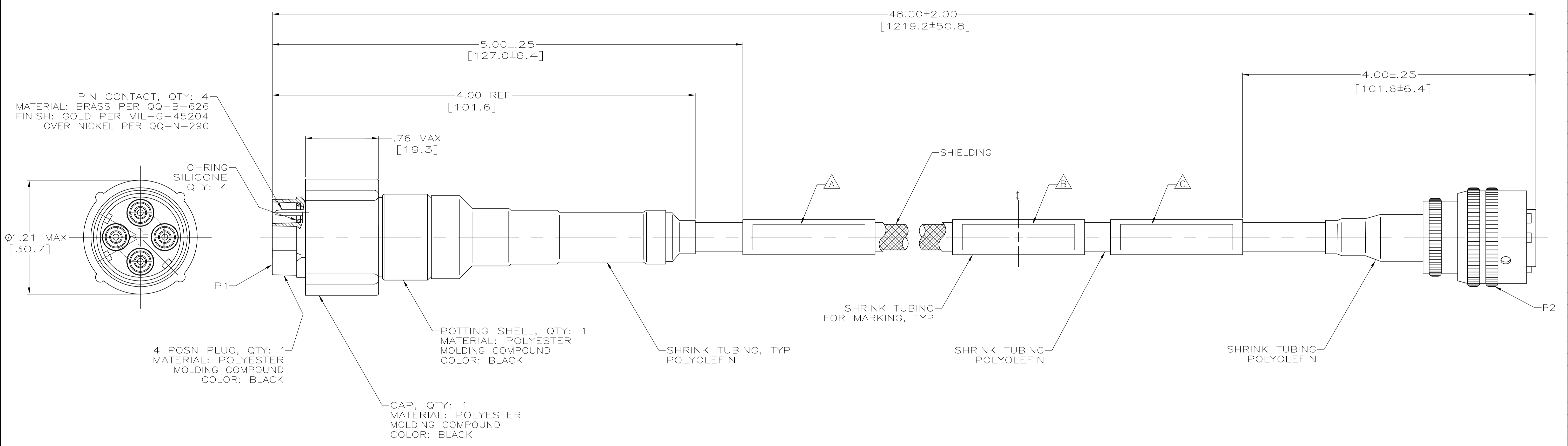

- SPECIAL MARKING PER MIL-STD-130.
- OPERATING VOLTAGE: 5 KVDC.

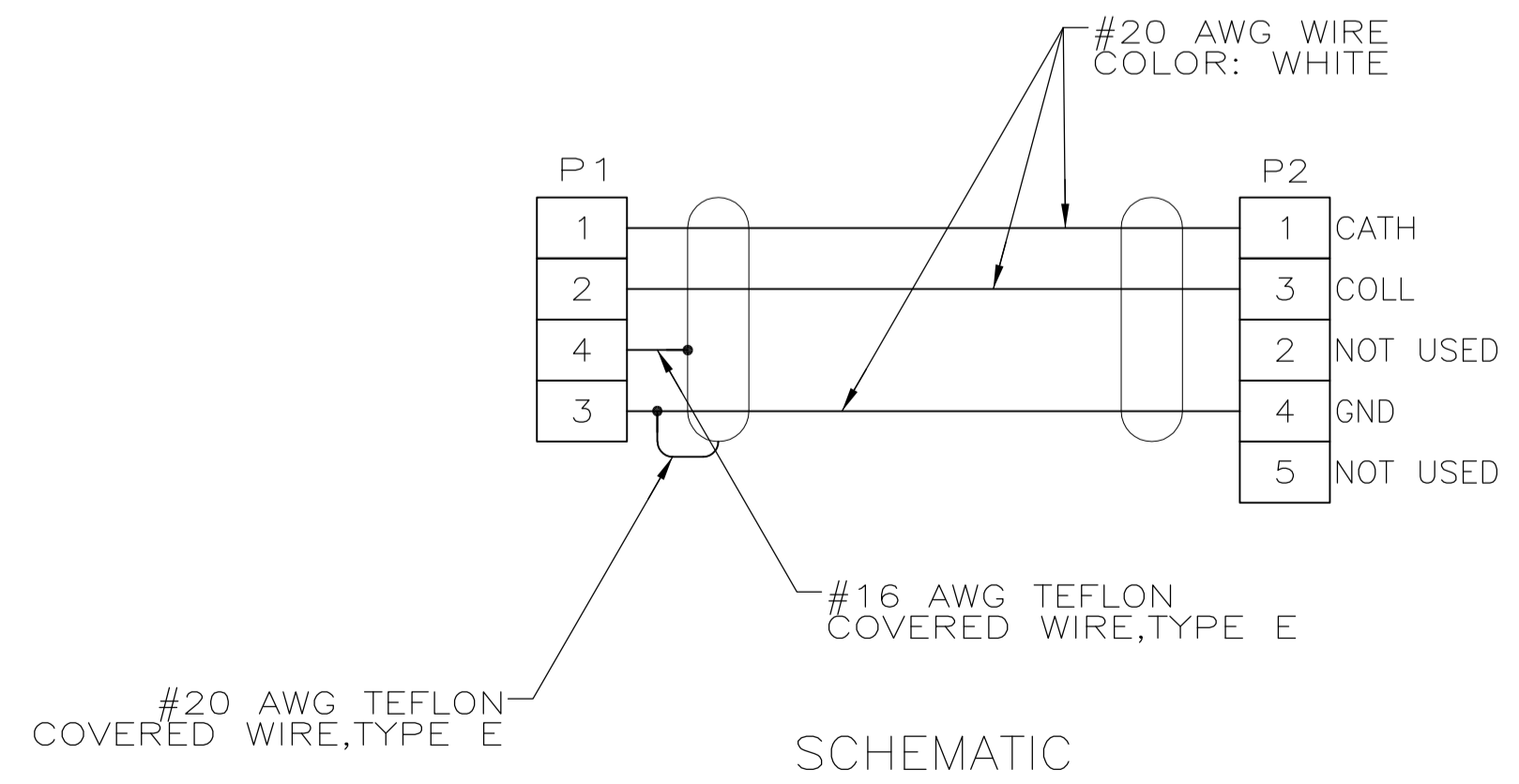

SCHEMATIC

P2 MATES WITH J2 ON UUT	HV CABLE ASSEMBLY 18323ASSY989C008H02 SER NO MFR AMP 00779	P1 MATES WITH DR TWT LOAD (J7) ON TEST INTERFACE PANEL	447324-1
\triangle	\triangle	\triangle	PART NO.
SPECIAL MARKING	SPECIAL MARKING	SPECIAL MARKING	

THIS DRAWING IS A CONTROLLED DOCUMENT.		DWN T. SHUEY 7-11-90	Tyco Electronics Corporation Tyco Electronics Corporation Harrisburg, PA 17105-3608	
DIMENSIONS: INCHES	TOLERANCES UNLESS OTHERWISE SPECIFIED:	CHK C. SHELLEY 7-11-90	APVD C. SHELLEY 7-11-90	NAME CABLE ASSEMBLY, PLUG 4 POSN, DOUBLE END, LGH
0 PLC ± -	1 PLC ± -	PRODUCT SPEC	APPLICATION SPEC	SIZE A1
2 PLC ± -	3 PLC ± -	WEIGHT	SCALE 2:1	RESTRICTED TO
4 PLC ± -	ANGLES ± -	CUSTOMER DRAWING	00779	447324
MATERIAL	FINISH	SCALE 2:1	SHEET 1 OF 1	REV D