



XE132 Evaluation Board Product Brief



XE132 Evaluation Board Product Brief

Proprietary and Confidential

Author: Acconeer

Version 1.2: 2021-04-21



Table of Contents

1	Introduction	4
2	XE132 Evaluation Board.....	5
2.1	Overview	5
2.2	Power.....	7
2.3	Not Mounted Components	7
2.4	Connectors.....	7
2.4.1	USB (J1).....	7
2.4.2	Power pin header (J3).....	8
2.4.3	2x5 JTAG/SWD pin header (J6)	8
2.4.4	2x10 pin header (J7)	8
2.4.5	Switches and buttons	9
2.5	Electrical Schematics	9
2.6	Component Placement Drawing.....	13
2.7	Bill of Material	14
3	References	16
4	Revision History.....	17
5	Disclaimer	18



1 Introduction

This document describes the Acconeer XE132 evaluation board containing the XM132 Entry module. The evaluation board provides access to the interfaces from the XM132 Entry module so that it can easily be flashed and debugged.

For More information please read:

- [XM132 Datasheet](#)
- [Acconeer Entry Module EVK HW User Guide](#)



2 XE132 Evaluation Board

2.1 Overview

The XE132 is an evaluation board including the XM132 Entry module. It makes the interfaces from the XM132 module accessible for evaluation and debug. It also enables flashing of the XM132 via USB-UART or SW-DP. The XM132 Entry module is included in the XE132 Evaluation board. In Picture 1 you will find the XE132 top side where the XM132 is mounted. Picture 2 shows the bottom side of XE132.

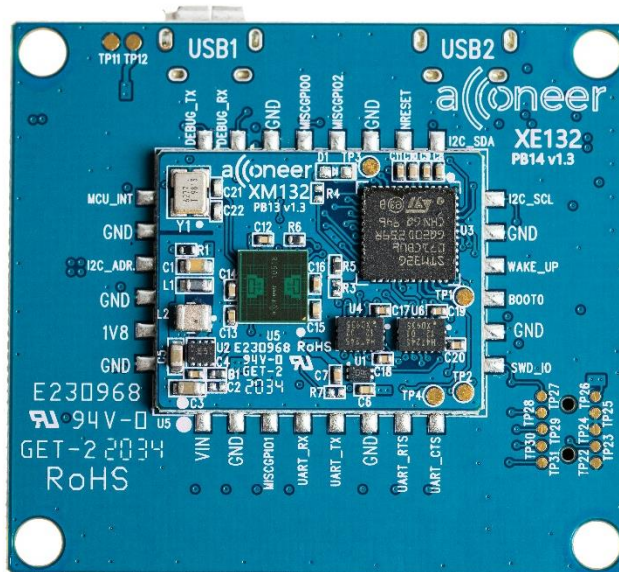

Picture 1. The XE132 top side where XM132 is mounted.

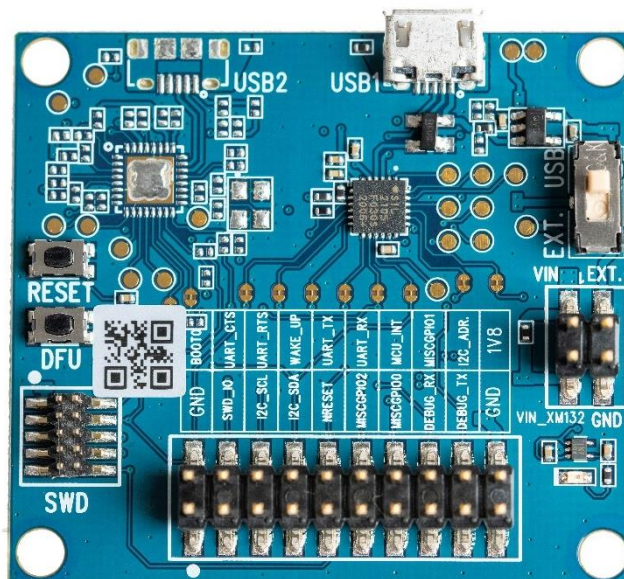

Picture 2. The XE132 bottom side.



The block diagram of XE132 is found in Figure 1 below.

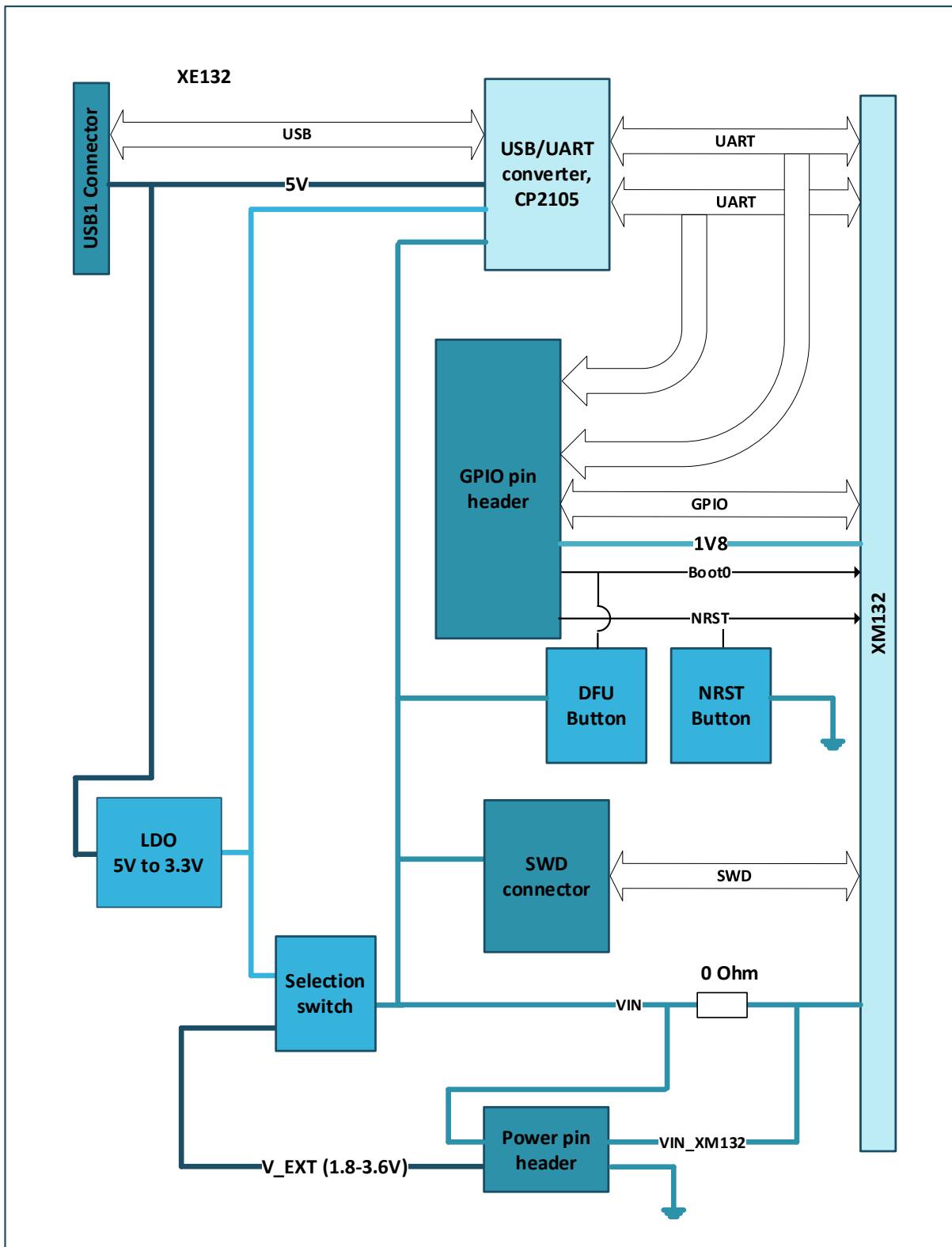

Figure 1. The block diagram of XE132.



2.2 Power

The XE132 is powered via the USB connector J1 and/or via the pin header J3. The USB 5V power domain supplies the USB-UART chip (U1). If the USB-UART interface is not used, a dedicated USB charger can be used.

The XM132 module mounted on the XE132 can be powered either from a 3.3V LDO (U4) which is supplied from the USB 5V power domain or from “V_EXT” in the J3 pin header. V_EXT should be between 1.8V to 3.6V. Typical value of V_EXT is 3.3V.

The power source for XM132 is determined by the setting of the switch “S1”. When the LED D1 on the XE132 is lit, the XM132 is powered. If power is supplied via V_EXT and the switch S1 is in position “V_EXT”, both the components on XE132 and XM132 are supplied from the external power supply.

It should be noted that regardless if “V_EXT” or “3.3V” is used to power XM132, the LED D1 will consume power since it is connected to “VIN”. If one wants to measure only the current consumed by XM132, power should be supplied to XM132 via the pin “VIN_XM132” in pin header J3. In this case, R25 should be unmounted and S1 should be placed in position “3.3V”. This way, all components on XE132 are supplied from the 3.3V LDO, but XM132 is supplied from the external power supply. D1 will not indicate if XM132 is powered after R25 has been removed.

The intention of the power pin header J3 is that it can be used both for supplying power to XM132 and for measuring current over a measurement resistor (R25). R25 is a 0 Ohm resistor, but the customer can change it to a low-value resistor with high accuracy in order to perform very accurate measurements of the XM132 current. See Table 2 for the pin assignment of pin header J3.

2.3 Not Mounted Components

As can be seen in the schematic in chapter 2.5, USB connector J2 and several other components are “No Mount”. These components are related to the FTDI I2C-USB bridge chip FT4222H which can be mounted on the PCB. It was added for internal Acconeer use, but customers are of course free to mount these components if they wish. The I2C interface is also accessible in pin header J7. Refer to Table 4.

2.4 Connectors

2.4.1 USB (J1)

USB is used as power supply for the XB132 as well as for flashing and communicating over UART. USB is connected to the Silicon Labs chip CP2105 which converts the UART interfaces from XM132 into USB data signals. The pinout of J1 is shown in Table 1.

Table 1. The pinout of J1.

Pin Number	Signal
1	VBUS
2	D-
3	D+



Pin Number	Signal
4	ID (GND)
5	GND

2.4.2 Power pin header (J3)

The power pin header J3 provides the possibility to supply the XM132 board with power from an external power supply. In Table 2, the pin assignment of J3 is shown:

Table 2. The pin assignment of the power pin header J3.

Pin Number	Signal	Pin Number	Signal
1	V_EXT	2	GND
3	VIN	4	VIN_XM132

2.4.3 2x5 JTAG/SWD pin header (J6)

The 2x5 JTAG/SWD pin header (1.27mm pitch) contains the signals needed for flashing the XM132 MCU via the SWD interface. The pinout matches that of the Cortex 10-pin JTAG/SWD Connector and is found in Table 3.

Table 3. The pinout of J6.

Pin Number	Signal	Pin Number	Signal
1	VIN_XM132	2	SWD_IO
3	GND	4	SWD_CLK_BOOT0
5	GND	6	NC (no TRACESWO available)
7	NC	8	NC
9	GND	10	NRESET

2.4.4 2x10 pin header (J7)

The 2x10 pin header (2.54mm pitch) contains miscellaneous GPIOs from the XM132 as well as 1V8 (output from switched power regulator on XM132). The pinout is found in Table 4.

Table 4. The pinout of J7.

Pin Number	Signal	Pin Number	Signal
1	GND	2	SWD_CLK_BOOT0
3	SWD_IO	4	UART_CTS
5	I2C_SCL	6	UART_RTS
7	I2C_SDA	8	WAKE_UP
9	NRESET	10	UART_TX
11	MISC_GPIO2	12	UART_RX
13	MISC_GPIO0	14	MCU_INT



Pin Number	Signal	Pin Number	Signal
15	DEBUG_UART_RX	16	MISC_GPIO1
17	DEBUG_UART_TX	18	I2C_ADDRESS
19	GND	20	1V8

2.4.5 Switches and buttons

There is one switch on XE132. S1 determines if XM132 is powered from the 3.3V LDO (U4) on XE132 or from an external power supply via pin header J3 (V_EXT).

There are two buttons on the XE132. J4, DFU (Device Firmware Upgrade), controls the signal “BOOT0” on the XM132. Button J5 controls the “NRESET” signal on XM132. In Table 5 the state of the buttons and the corresponding signal states are listed.

Table 5. The states of the buttons J4 and J5.

Button	Open (default)	Closed
J4	BOOT=0	BOOT0=1
J5	NRESET=1	NRESET=0

2.5 Electrical Schematics

The electrical schematics for the XE132 are found on the following pages:

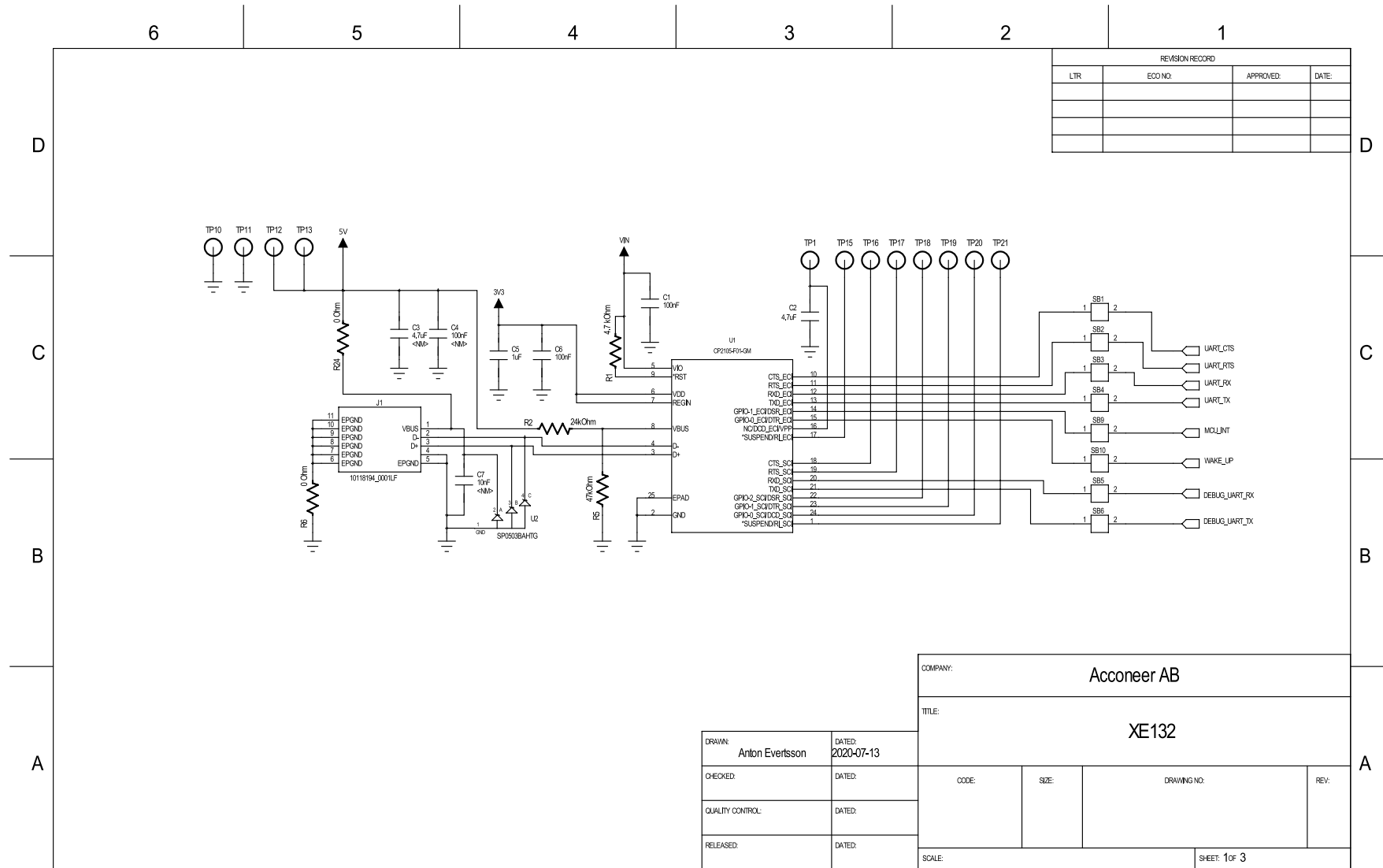

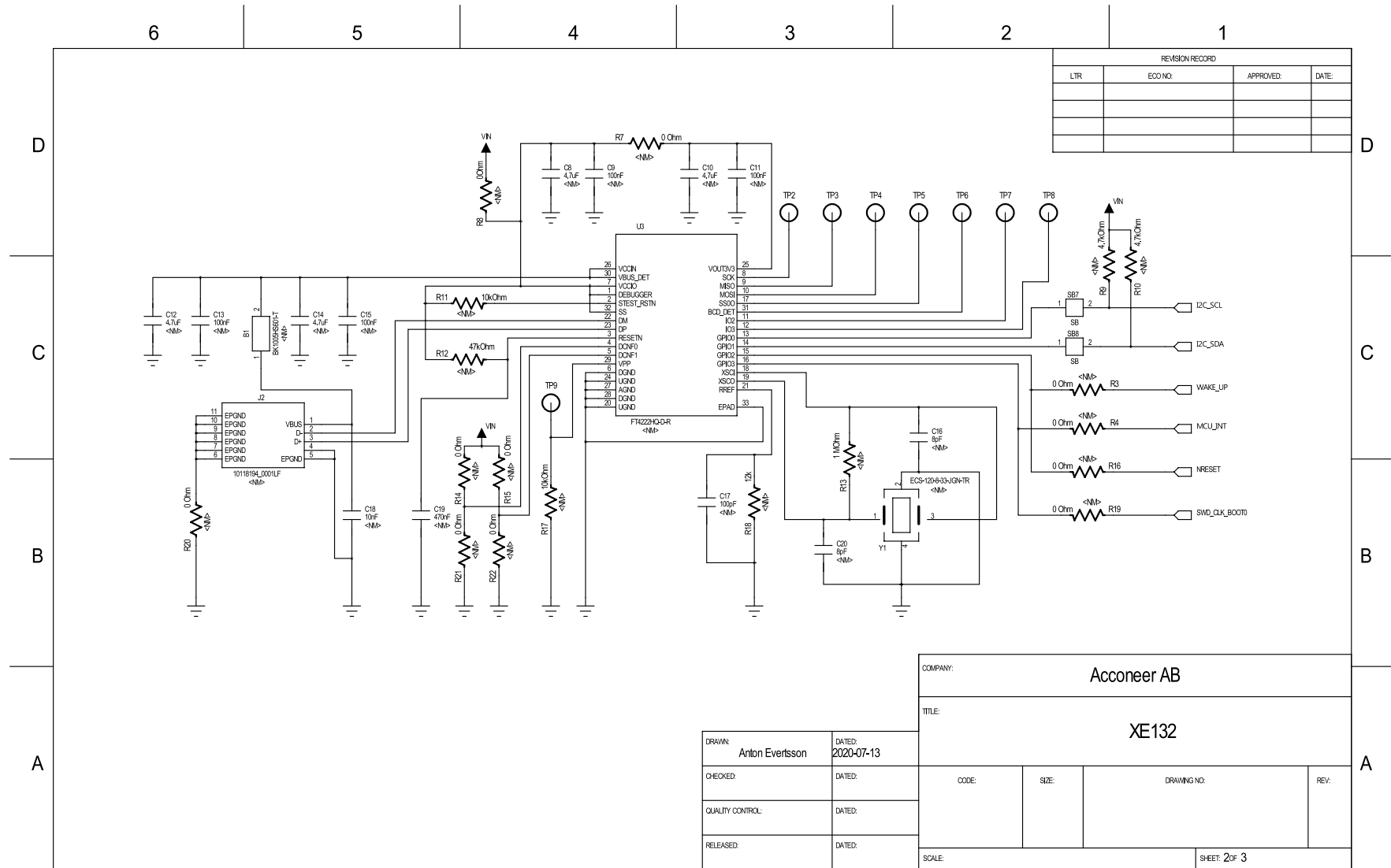

REVISION RECORD			
LTR	ECO NO.	APPROVED	DATE

COMPANY: Acconeer AB			
TITLE: XE132			
DRAWN: Anton Evertsson	DATED: 2020-07-13	CODE:	REV:
CHECKED:	DATED:	SIZE:	DRAWING NO.
QUALITY CONTROL:	DATED:	SCALE:	
RELEASED:	DATED:	SHEET: 2 of 3	

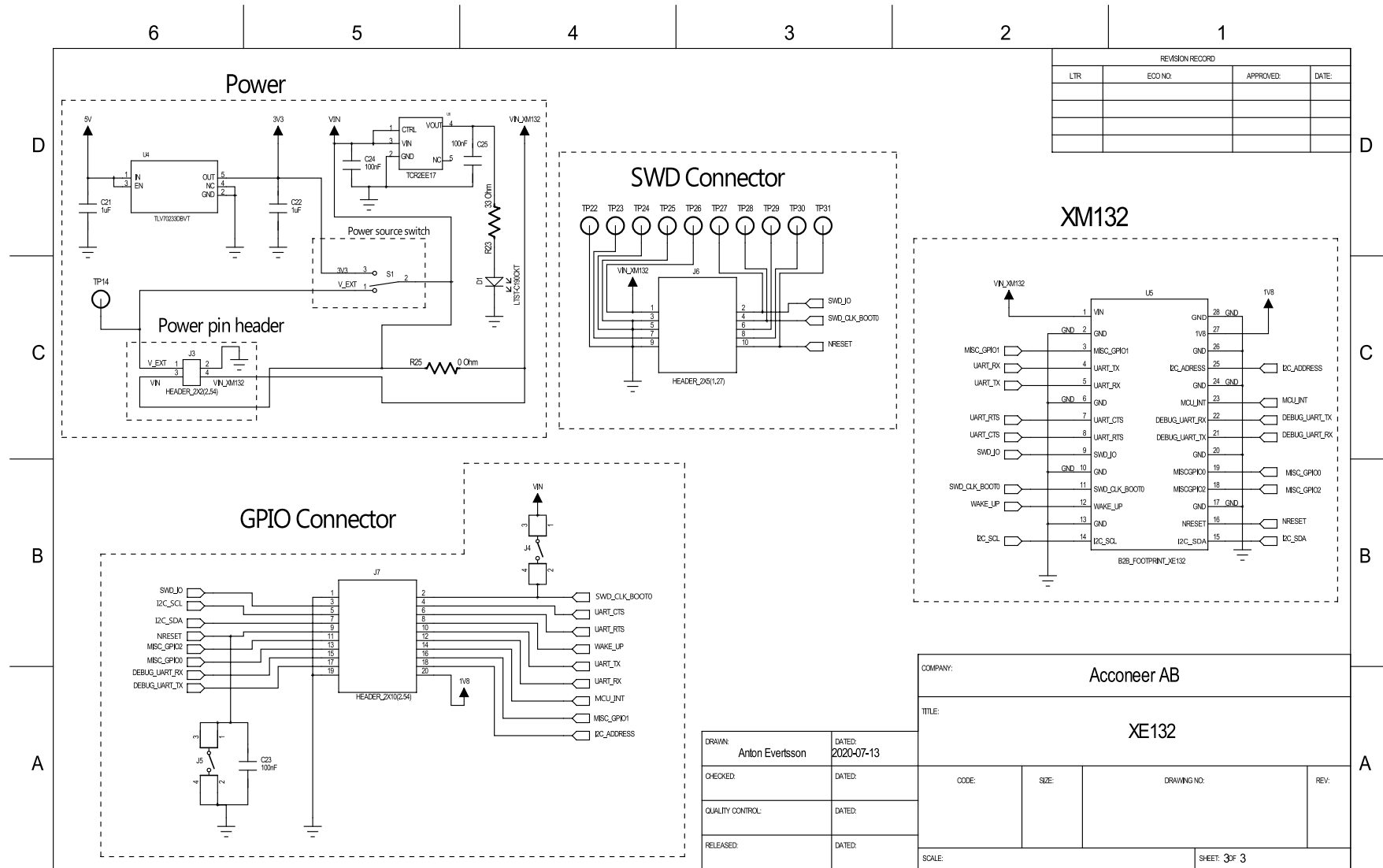



Bottom Side:

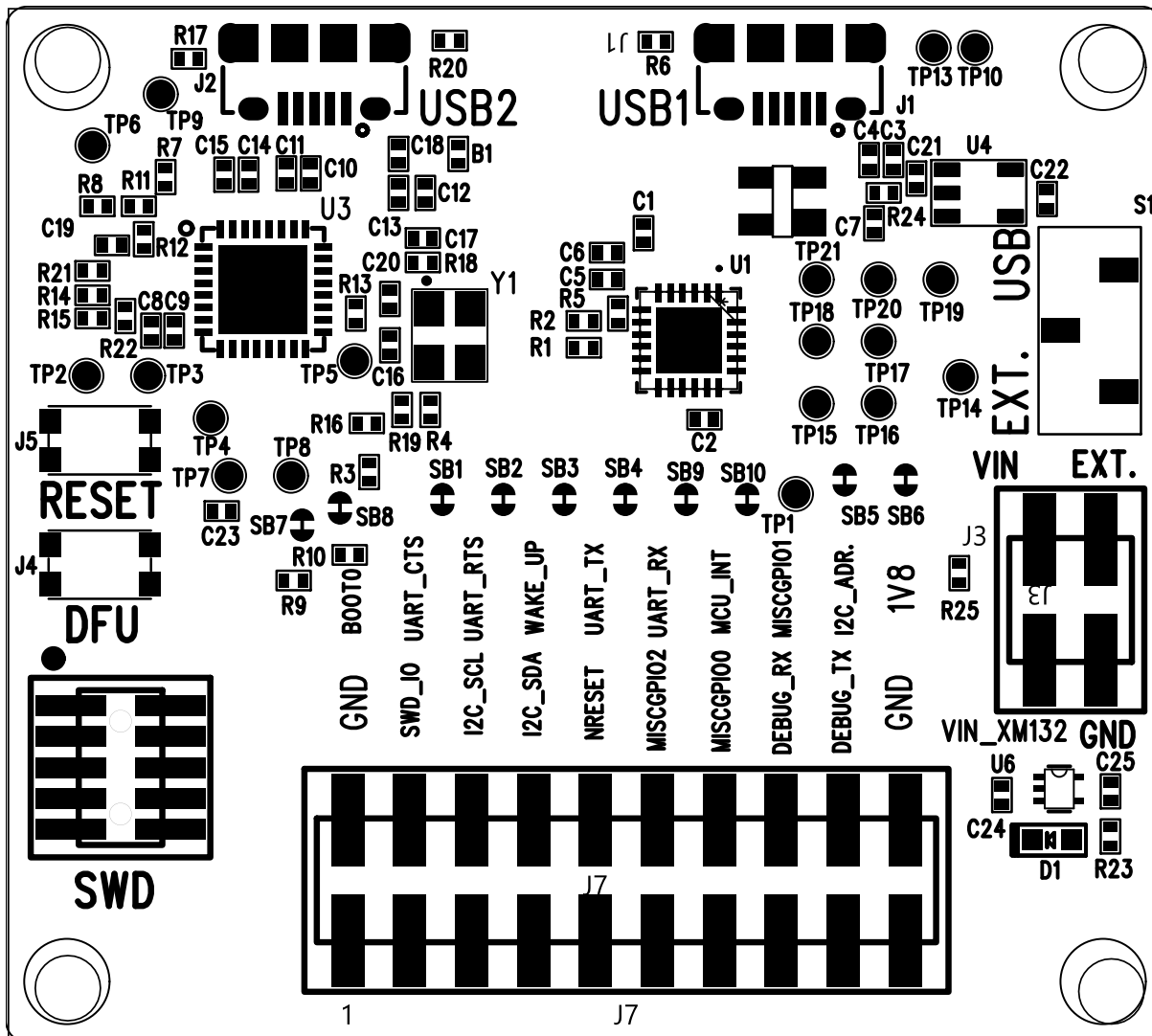

2.7 Bill of Material

Table 6 shows the BOM for the XE132

Table 6 The BOM for the XE132.

Component Ref.	Specification	QTY	Value	Comment
C1, C6, C23, C24, C25	Chip Capacitor 0402,X7R,100nF,10%,50V	5	100nF	
C2	Chip Capacitors 4.7uF 10V X5R 0402	1	4.7uF	



R6, R24, R25	Chip Resistor,0402,5%,0R	3	0Ohm	
C5, C21, C22	Chip Capacitors 0402 X5R 1UF 10% 10V	3	1uF	
R1	Chip Resistor 0402,5%,4.7K	1	4.7kOhm	
R5	Chip Resistor,0402,5%,47K	1	47kOhm	
J4, J5	Tactile switch: KMR741NG-ULC-LFS	2		Manufacturer: C&K
J1	Micro USB 2.0 B Receptacle STD 10118194-0001LF	1		Manufacturer: Amphenol
R23	Chip Resistor,0402,5%,33R	1	33Ohm	
R2	Chip Resistor,0402,5%,24K	1	24kOhm	
U2	TVS Diode 30kV SOT143-4 SP0503BAHTG	1		Manufacturer: Littelfuse Inc.
U1	IC USB-UART Transfer QFN-24 CP2105-F01-GM	1		Manufacturer: Silicon Labs
U4	IC LDO 3.3 V 100 Ma DBV TLV70233DBVT	1		Manufacturer: TI
U5	XM132 Entry Radar Sensor Module	1		Manufacturer: Acconeer AB
U6	IC LDO 1.8V 200mA TCR2EE17,LM(CT	1		Manufacturer: Toshiba
D1	LED red clear chip smd LTST-C190CKT	1		Manufacturer: Lite-On Inc
S1	JS102011JCQN, SWITCH SLIDE SPDT 300MA 6V	1		Manufacturer: C&K
J6	SMD HEADER 2X5 Pitch 1.27MM FTSH-105	1		Manufacturer: Samtec
J3	SMD HEADER 2X2 Pitch 2.54mm TSM-102	1		Manufacturer: Samtec
J7	SMD HEADER 2X10 Pitch 2.54MM TSM-110	1		Manufacturer: Samtec



3 References

1. XM132 datasheet:
<https://developer.acconeer.com/>
2. Acconeer Entry Module EVK HW User Guide
<https://developer.acconeer.com/>



4 Revision History

Date	Version	Changes
2020-09-25	1.0	Original Version
2021-02-05	1.1	Updated XE132 schematic, corrected naming in U2 B2B footprint.
2021-04-21	1.2	ISO 14001 updates



5 Disclaimer

The information herein is believed to be correct as of the date issued. Acconeer AB (“**Acconeer**”) will not be responsible for damages of any nature resulting from the use or reliance upon the information contained herein. Acconeer makes no warranties, expressed or implied, of merchantability or fitness for a particular purpose or course of performance or usage of trade. Therefore, it is the user’s responsibility to thoroughly test the product in their particular application to determine its performance, efficacy and safety. Users should obtain the latest relevant information before placing orders.

Unless Acconeer has explicitly designated an individual Acconeer product as meeting the requirement of a particular industry standard, Acconeer is not responsible for any failure to meet such industry standard requirements.

Unless explicitly stated herein this document Acconeer has not performed any regulatory conformity test. It is the user’s responsibility to assure that necessary regulatory conditions are met and approvals have been obtained when using the product. Regardless of whether the product has passed any conformity test, this document does not constitute any regulatory approval of the user’s product or application using Acconeer’s product.

Nothing contained herein is to be considered as permission or a recommendation to infringe any patent or any other intellectual property right. No license, express or implied, to any intellectual property right is granted by Acconeer herein.

Acconeer reserves the right to at any time correct, change, amend, enhance, modify, and improve this document and/or Acconeer products without notice.

This document supersedes and replaces all information supplied prior to the publication hereof.



Acconeer AB
IDEON Gateway
Scheelevägen 27
223 63 LUND
Sweden

www.acconeer.com
info@acconeer.com
+46 10 218 92 00