

REVISIONS					
REV	ECO	DESCRIPTION	DATE	BY	APPR
A1	-	FIRST RELEASE	Jun.27,2015	Drack	Tommy
A2	-	UPDATE THE SHAPE	APR.18,2016	Drack	Tommy

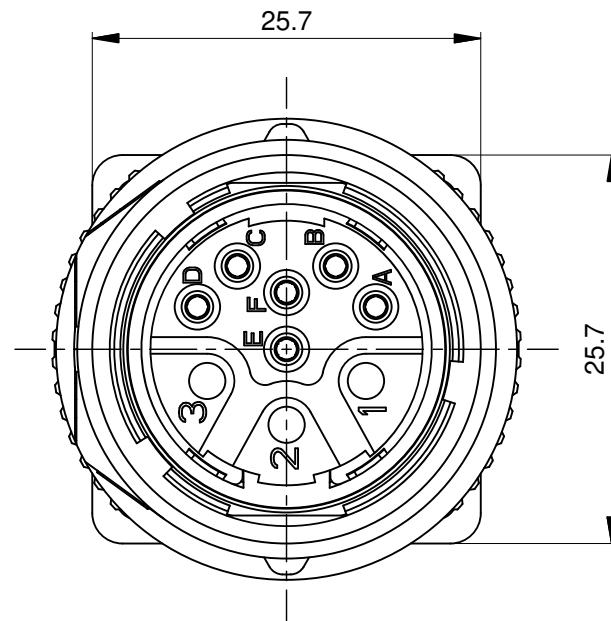
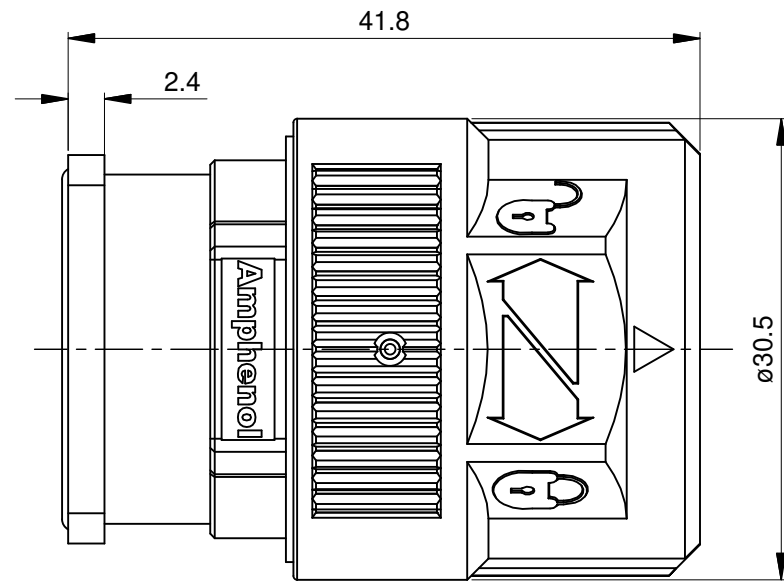

NOTES: UNLESS OTHERWISE SPECIFIED

- MATERIAL:
INSULATION INSERT: PA66, UL94 V0
SEAL: VITON
HOUSING BODY: ZINC DIE CAST, NICKEL PLATED
COUPLING NUT: ZINC DIE CAST, NICKEL PLATED
- SPECIFICATIONS:
2.1 CURRENT RATING: SIGNAL: 10 AMPS
POWER: 30AMPS
2.2 VOLTAGE RATING: SIGNAL: 250V AC/DC
POWER: 630V AC/DC
2.3 OPERATING TEMPERATURE: -20°C TO +130°C
2.4 DIELECTRIC WITHSTANDING VOLTAGE: LESS THAN 2 MILLIAMPS CURRENT LEAKAGE @ SIGNAL: 2500VOLTS AC.
POWER: 6000 VOLTS AC.
2.5 DEGREE OF PROTECTION: IP67 (MATED CONDITION)
2.6 DEGREE OF POLLUTION: 3 PER UL840
2.7 OVERVOLTAGE CATEGORY: III PER UL840
2.8 MATING CYCLE DURABILITY: >500 CYCLES
2.9 RoHS COMPLIANT

3. ALL DIMENSIONS ARE FOR REFERENCE USE ONLY.

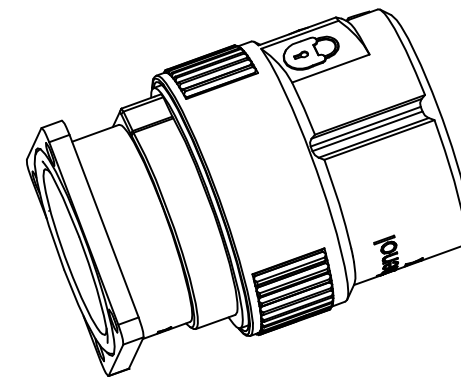
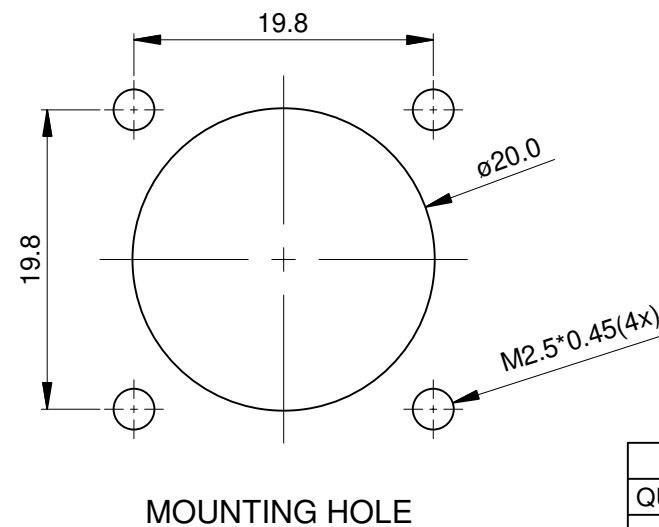
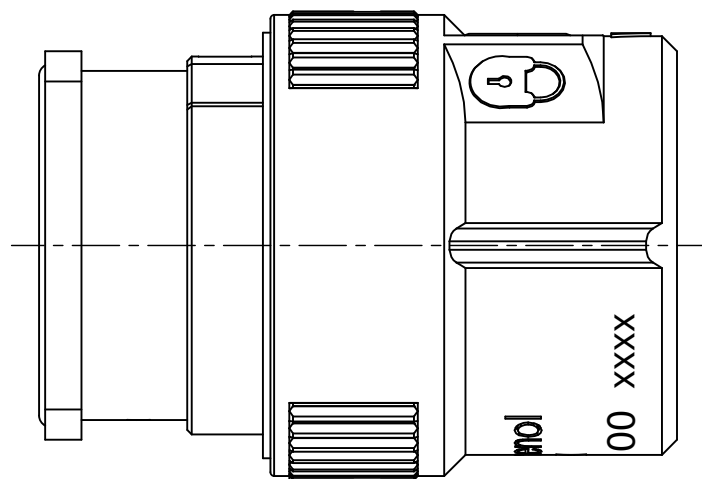

SEE PART NUMBER		CHART		DESCRIPTION		ITEM
QUANTITY	PART NUMBER					
MATERIALS LIST						
UNLESS OTHERWISE SPECIFIED 1) All dimensions are in metric (mm). 2) Tolerances are as follows: 1 PL DEC ±0.30 2 PL DEC ±0.15 3 PL DEC ±0.08 3) Note reference =		SIGNATURES DRAWN: Drack CHECKED: ENGINEER: APPROVAL:		DATE APR.18,2016		<h1>Amphenol</h1> Sine Systems - www.amphenol-sine.com 44724 Morley Drive Clinton Township, MI 48036
MATERIAL SPECIFICATIONS:		CUSTOMER:		THIS DRAWING IS SUPPLIED FOR INFORMATION ONLY. DESIGN FEATURES, SPECIFICATIONS AND PERFORMANCE DATA SHOWN HEREON ARE THE PROPERTY OF THE AMPHENOL CORPORATION. NO RIGHTS OF REPRODUCTION ARE IMPLIED. ALL DIMENSIONS ARE SUBJECT TO NORMAL MANUFACTURING VARIATIONS.		
PROCESS SPECIFICATIONS:		CUSTOMER:		SIZE B C-		DWG NO: MB2GJNNG36
NEXT ASSY:		SCALE: NONE		REVISION A2		SHEET 1 OF 1

TITLE: M23B,PLUG,STR,9POS(3+6),FLANGE,CHECKMATE
DWG NO: MB2GJNNG36
REV: A2
SH: 1
OF: 1