

ATLANTIC VERSION TERMINATOR INTERFACE ADAPTER	PART NUMBER	REVISION	DESCRIPTION	FEED TYPE	APPLICATOR STYLE CONVERSION CHART						
					CONVERT TO	PART NUMBERS REQUIRED					
	2151551-2	G	FINE CRIMP HEIGHT ADJUST	PNEUMATIC	-	-	-	-	-	-	
	2151551-5	G	FINE CRIMP HEIGHT ADJUST	SERVO LATCH PLATE	2119951-1	-	8-2151551-5	1901094-3	-	2168400-6 (QUANTITY 2)	
	2151551-6	G	NON-CRIMP HEIGHT ADJUST	SERVO LATCH PLATE	2161326-1	-	8-2151551-4	-	-	-	
	2151551-7	G	FINE CRIMP HEIGHT ADJUST	NONE	-	-	-	-	-	-	
	7-2151551-7	A	CRIMP TOOLING KIT	-	-	-	-	-	-	-	

APPLICATOR DATA		
CRIMP	SIZE	TYPE
WIRE	3.30 mm [.130]	F
INSUL	4.06 mm [.160]	F

APPLICATOR INSTRUCTIONS  
408-10389

TERMINAL DATA: TE TERMINAL		TE CRIMP SPECIFICATION	
TERMINAL NAME: AMP MCP 6.3/4.8 K LITEALUM CONTACT			
WIRE STRIP LENGTH		INSULATION DIAMETER RANGE	
3.40-4.00 mm [.134-.157 IN]		Ø 3.56-3.74mm [.140-.147 IN]	
TERMINAL APPLICATION SPECIFICATION	114-94204	-	-
TERMINALS APPLIED			
TE TERMINAL	TE TERMINAL	TE TERMINAL	TE TERMINAL
2-2177839-1	2-2177839-3		

WIRE SIZE	CRIMP HEIGHT mm [INCH]	CRIMP HEIGHT REFERENCE SETTING
4.00mm2	1.90±0.04 [.0748±.0016]	8.5

- 1. RECOMMENDED SPARE PARTS
- 2. GREASE BEARING SURFACES LIGHTLY
- 3. LUBRICATE DAILY PER THE APPLICATOR INSTRUCTION SHEET SUPPLIED WITH THE APPLICATOR.
- 4. APPLICATOR SPECIFIC DATA TO BE ENTERED INTO BLANK MEMORY CHIP AT ASSEMBLY. SEE BELOW FOR PART NUMBER:  
 PNEUMATIC FEED WITH "SMART APPLICATOR" CONVERSION: 8-2151551-4  
 SERVO FEED WITH "FINE CRIMP HEIGHT ADJUST": 8-2151551-5  
 SERVO FEED WITH "NON-CRIMP HEIGHT ADJUST": 8-2151551-6
- 5. ADJUSTMENT OF THE STRIPPER MAY BE REQUIRED WHEN MOVING THE APPLICATOR BETWEEN BENCH AND LEADMAKER APPLICATIONS.
- 6. APPLY PART NUMBER 1-23419-5 LOCTITE TO THREADS OF ITEMS 62. APPLY PART NUMBER 2-23419-6 LOCTITE TO THREADS OF ITEMS 99 & 242. FOR -6 ONLY APPLY PART NUMBER 1-23419-5 LOCTITE TO THREADS OF ITEMS 37.
- 7. GREASE THREADS, GROOVE AND O-RING ON ITEMS 35 & 252.
- 8. MAGNET, ITEM 166 MUST BE ORIENTED CORRECTLY IN ORDER TO PROPERLY ACTUATE THE COUNTER.
- 9. CRIMP HEIGHT REFERENCE SETTING WAS THE SETTING USED WHEN THE APPLICATOR WAS QUALIFIED AT THE FACTORY. ADJUSTMENT MAY BE NECESSARY WHEN RUNNING APPLICATOR IN THE FIELD.
- 10. TERMINAL PITCH NOT COMPATIBLE WITH MECHANICAL FEED.
- 11. TO CONVERT THE APPLICATOR TO A NON-CARRIER CUTTING STYLE, REMOVE ITEM 13 AND ATTACH TO THE LOCATION ON THE BACK SIDE OF THE HOUSING. REFER TO INSTRUCTION SHEET FOR ADDITIONAL INFORMATION.
- 12. WHEN ASSEMBLING A NON CRIMP HEIGHT ADJUST APPLICATOR (-6) USE SHIMS FROM ITEM 260 TO ACHIEVE A NOMINAL SHIM HEIGHT.
- 13. SET THE FINE CRIMP HEIGHT ADJUSTMENT HEAD TO PROPER CRIMP HEIGHT PRIOR TO TIGHTENING/LOCKING THE BRASS TIP SET SCREW, ITEM 99, AGAINST THE ADJUSTMENT BOLT THREADS.
- 14. APPLICATOR TO BE USED IN CONJUNCTION WITH LEADMAKER INTGRATION KIT, P/N 2280475-1 FOR CLAMPING AND SENSING OF FEED TRACK.

**\*WARNING**  
 ON INSTALLATION, SET WIRE DISC, ITEM 40 TO LARGEST WIRE SIZE SETTING. USE OF SETTINGS BELOW MINIMUM REQUIRED CRIMP HEIGHT SETTING WILL CAUSE DAMAGE TO CRIMP TOOLING.

-77	-7	-6	-5	-2	PART NO	DESCRIPTION	ITEM NO
-	1	1	1	1	2-1722335-1	THREAD BOLT GEWINDEBOLZEN	268
-	-	1	-	-	2119957-2	APPLICATOR SHIM PACK	260
-	1	-	1	1	8-21084-0	O-RING, .676 ID, .070 DIA. MAT.	252
-	-	-	-	1	2119640-1	PUSH ROD, AIR FEED	250
-	-	-	-	1	2079988-1	BUSHING, LCH5-12, MISUMI	249
-	-	-	-	1	2119641-1	FEED CAM, AIR FEED	248
-	1	-	1	1	2119798-1	DETENT PIN	247
-	1	-	1	1	1-22279-3	SPRING, COMPRESSION	246
-	-	1	-	-	2119758-1	RAM, AMP STYLE, SIDE FEED, NON-ADJ.	245
-	1	1	1	1	2119082-4	CAM, SNAIL, INSULATION ADJUSTMENT	244

**ATLANTIC VERSION**  
 Shown on sheets 1 of 4 & 2 of 4  
 (Pacific version shown on sheets 3 of 4 & 4 of 4)

SET UP GAUGE	LOC	DIST	REVISIONS					
2119599-1	A	66	P	LTN	DESCRIPTION	DATE	OWN	APVD
			D4		ECR-15-003249	3MAR15	RS	LZ
			E		ECR-15-015082	14OCT2015	DJG	DS
			F		ECR-16-002618	23FEB2016	KH	CT
			G		ECR-16-013608	23SEP2016	JH	CT

-	1	1	1	1	2079764-1	WASHER, WAVE SPRING, CREST-TO-CREST	243
-	1	1	1	1	2119083-1	RETAINER, INSULATION DIAL	242
-	1	1	1	1	7-18023-7	SCR, SKT HD CAP M3 X 4.0	241
-	-	2	2	-	2168400-6	SHCS, LOW HEAD, RoHS, M5 X 16	240
-	-	-	-	1	2063440-1	AIR FEED MODULE	238
-	-	1	1	-	2119740-2	TAG, IDENTIFICATION	213
-	-	1	1	-	1901094-3	SPACER, FEEDER	198
-	-	-	-	2	21045-3	RING, RETAIN, EXTERN, 3/16 CRESCENT	172
-	1	1	1	1	994969-1	MAGNET, RARE EARTH HIGH ENERGY	166
-	REF	REF	REF	REF	994970-2	COUNTER, MAGNETIC	164
-	-	-	-	1	240638-1	SPRING, FEED FINGER	163
-	-	-	-	1	3-23627-7	PIN, RETAIN, GRVD, 3/16 X .854	137
-	-	-	-	1	2119799-1	HOLDER, FEED FINGER, AF	136
-	-	REF	REF	-	SEE NOTE 4	MEMORY CHIP, PROGRAMMED	135
-	-	1	1	-	1633743-1	SERVO FEED LATCH ASM	133
-	1	1	1	1	1-22281-8	SPRING, COMPRESSION	121
-	1	1	1	1	1-18028-2	WASHER, FLAT, REG M4	119
-	-	REF	REF	-	2119944-1	FEED FINGER ASSEMBLY, SF	117
-	1	1	1	1	2256587-1	SCR, SET, SOFT TIP, M4	99
-	1	1	1	1	1-690438-0	FRONT STRIP GUIDE	96
-	2	2	2	2	2168083-1	SCR, SKT HD CAP, RoHS, M3 X 8.0	95
-	1	1	1	1	2168083-6	SCR, SKT HD CAP, RoHS, M5 X 65	93
-	1	1	1	1	455888-3	SPACER, CRIMPER	82
-	1	1	1	1	2119956-1	DOCUMENTATION PACKAGE	71
-	1	-	-	1	2119740-1	TAG, IDENTIFICATION	67
-	2	2	2	2	2168078-1	SCREW, DRIVE, RH, RoHS, 2 x .188	66
-	1	-	-	1	2119793-1	LIMITER, ADJUSTMENT BOLT	63
-	3	-	3	3	992763-5	SCR, SET, SOC, CONE POINT, M3 X 4.0	62
-	1	1	1	1	2-18032-5	SCR, SET, FLT POINT M5 X 20.0	61
-	1	1	1	1	2079383-4	SCR, BHSC, RoHS (M4 X 8)	60
-	-	-	-	1	5-18022-5	SCR, HEX HD CAP, M4 X 6.0	59
-	-	-	-	1	1338685-1	PAWL, FEED	56
-	4	4	4	4	2168400-1	SHCS, LOW HEAD, RoHS, M4 X 12	54
-	2	2	2	2	2168083-8	SCR, SKT HD CAP, RoHS, M4 X 16	53
-	1	1	1	1	5018030-1	NUT, HEX, REG, RoHS, M3	52
-	1	1	1	1	811242-5	BUMPER, HOLD DOWN	51
-	1	1	1	1	690753-2	SPACER, TONKER	50
-	-	-	-	1	18023-9	SCR, SKT HD CAP M4 X 6.0	49
-	1	1	1	1	2-2119656-3	APPLICATOR BASIC ASSEMBLY, SF	46
-	1	-	-	1	2119370-1	RAM, AMP STYLE, SIDE FEED	44
-	1	1	1	1	2079383-7	SCR, BHSC, RoHS (M8 X 25)	41
-	1	-	-	1	2119645-1	DISC, NUMBERED FA WIRE ADJUSTMENT	40
-	1	-	-	1	2119957-1	APPLICATOR SHIM PACK	39
-	1	1	1	1	2119644-2	RAM WASHER, PRECISION	38
-	1	1	1	1	2119085-1	FA HEAD, ATLANTIC STYLE	37
-	1	-	-	1	2119092-1	BOLT, ADJUSTMENT	35
-	1	1	1	1	1-1752356-2	SUPPORT, TERMINAL	34
-	2	2	2	2	2079383-5	SCR, BHSC, RoHS (M4 X 20)	33
-	1	1	1	1	2161328-1	HEX HEAD, FLANGED, M5 X 8mm LONG	32
-	1	1	1	1	1320908-7	SPACER, STRIP GUIDE	30
-	1	1	1	1	1901086-1	PLATE, STRIP GUIDE	29
-	1	1	1	1	1-455888-0	SPACER, CRIMPER	28
-	2	2	2	2	22283-1	SPRING, COMPRESSION	27
-	1	1	1	1	356835-1	LEVER, DRAG RELEASE	26
-	1	1	1	1	1803142-1	DRAG, TERMINAL	25
-	1	1	1	1	1320928-2	STRIP GUIDE	24
-	1	1	1	1	980371-4	SCR, SKT HD SHLDR 5.0 DIA X 6.0	23
-	1	1	1	1	2168083-2	SCR, SKT HD CAP, RoHS, M4 X 8.0	21
-	1	1	1	1	1-18028-2	WASHER, FLAT, REG M4	20
-	1	1	1	1	690472-2	STRIPPER	19
-	1	1	1	1	2119806-1	INSERT, SHEAR	13
-	1	1	1	1	3-22280-3	SPRING, COMPRESSION	12
-	1	1	1	1	1-356885-5	STOP, SHEAR	11
-	1	1	1	1	2119805-1	SHEAR HOLDER, FRONT	10
-	1	1	1	1	462006-6	FLOATING SHEAR, FRONT	9
-	1	1	1	1	2161316-2	ANVIL, COMBINATION	8
-	1	1	1	1	2-240641-9	SPACER	7
-	-	-	-	-	-	-	6
-	1	1	1	1	1-1722335-0	SHEAR DEPRESSOR ASSEMBLY	5
-	1	1	1	1	5-238011-2	BLOCK, CRIMPER SPACER	4
-	1	1	1	1	1722335-8	CRIMPER, INSULATION F	3
-	-	-	-	-	-	-	2
-	1	1	1	1	2217302-2	CRIMPER, WIRE, CONICAL BLEND	1

DIMENSIONS:		TOLERANCES UNLESS OTHERWISE SPECIFIED:		APPROVED:		NAME:	
mm	0 PLC ±	1 PLC ±	2 PLC ±	3 PLC ±	4 PLC ±	5 PLC ±	ANGLES ±
FINISH:		MATERIAL:		WEIGHT:		SCALE:	
-		-		-		-	

DATE	BY	CHK	APP'D	PRODUCT SPEC	APPLICATION SPEC	SIZE	CAGE CODE	DRAWING NO	RESTRICTED TO
18JAN2012	R. KNEPPER					A1	00779	2151551	REV G
18JAN2012	T. ELBIN								
18JAN2012	M. CLIFFORD								

Customer Accessible Production Drawing

LOC		DIST		REVISIONS			
A	66	P	LTM	DESCRIPTION	DATE	OWN	APVD
		-		SEE SHEET 1			

### FEED TYPE PNEUMATIC

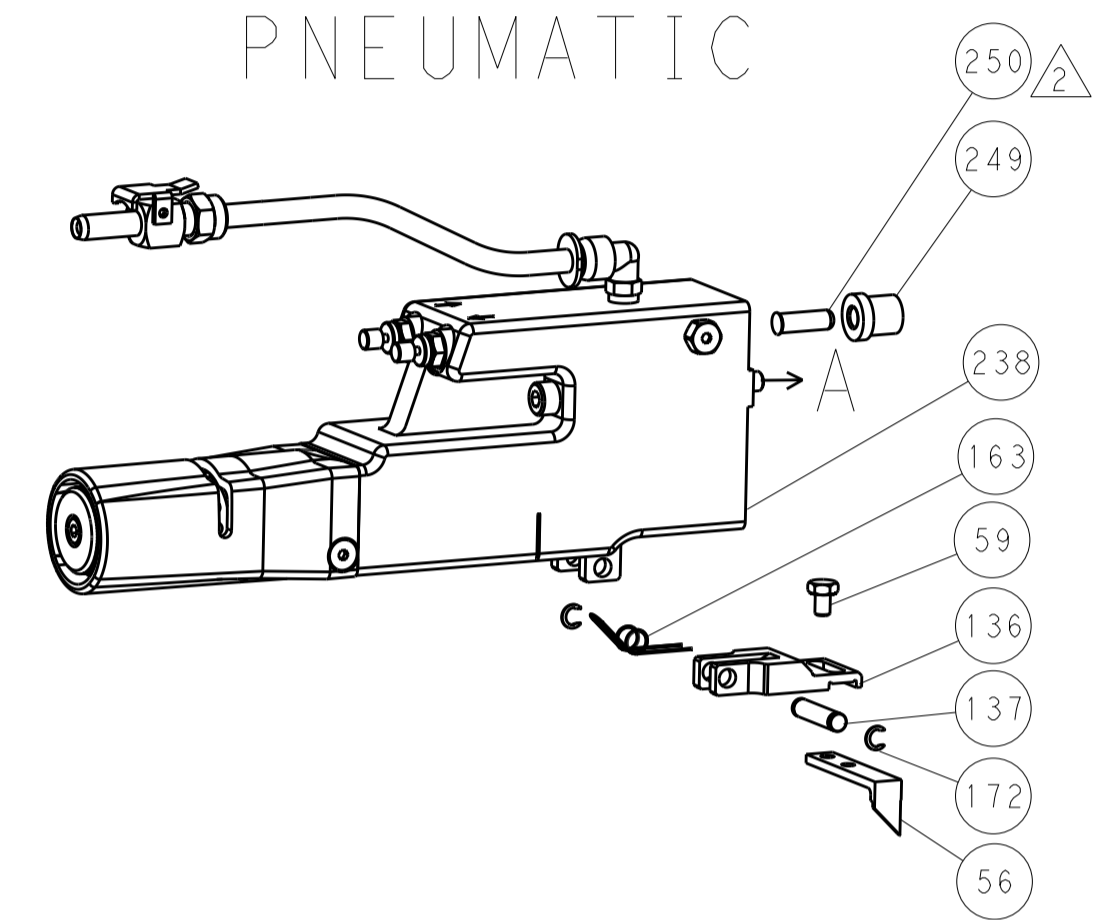

### SERVO LATCH PLATE

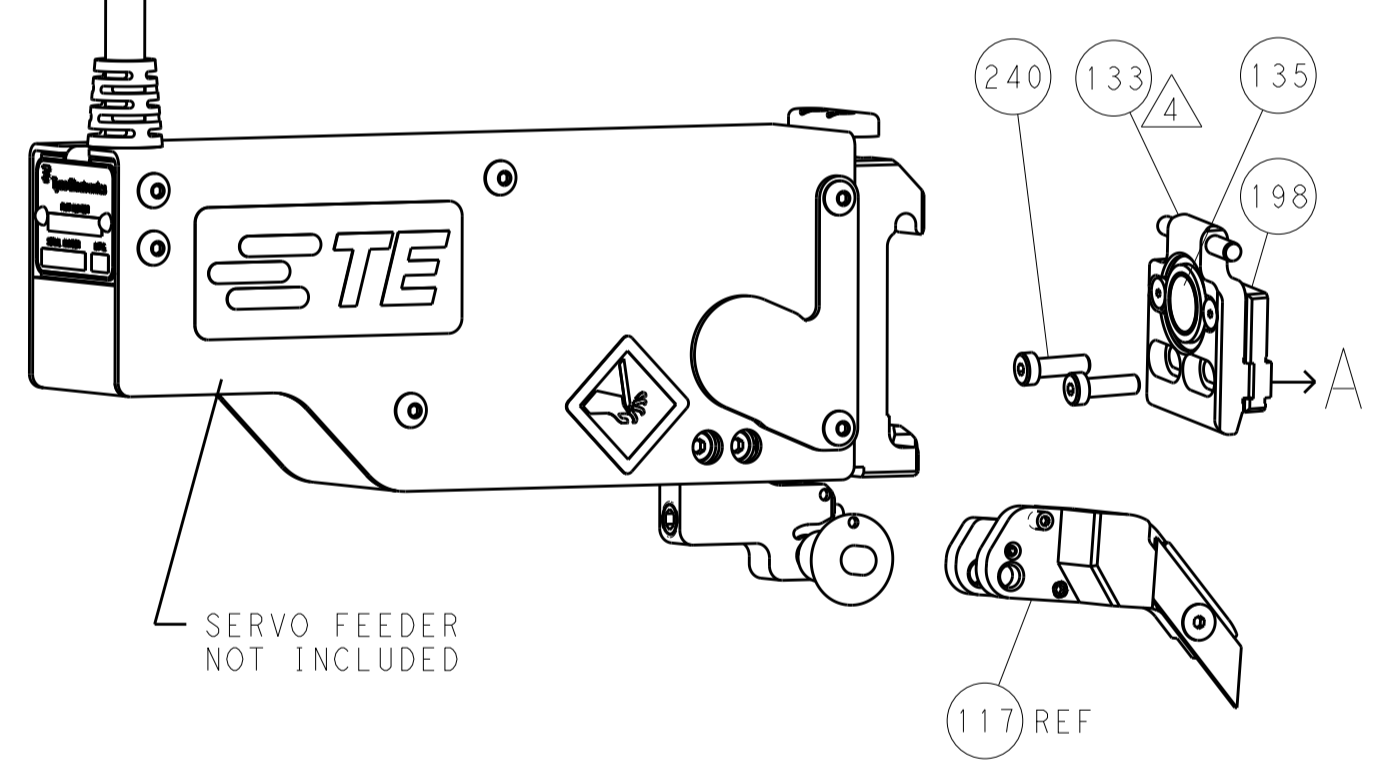

### CAM POSITIONS

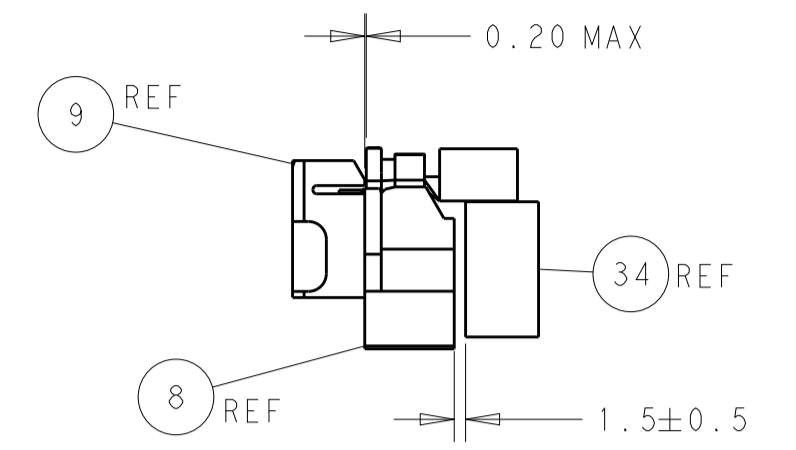
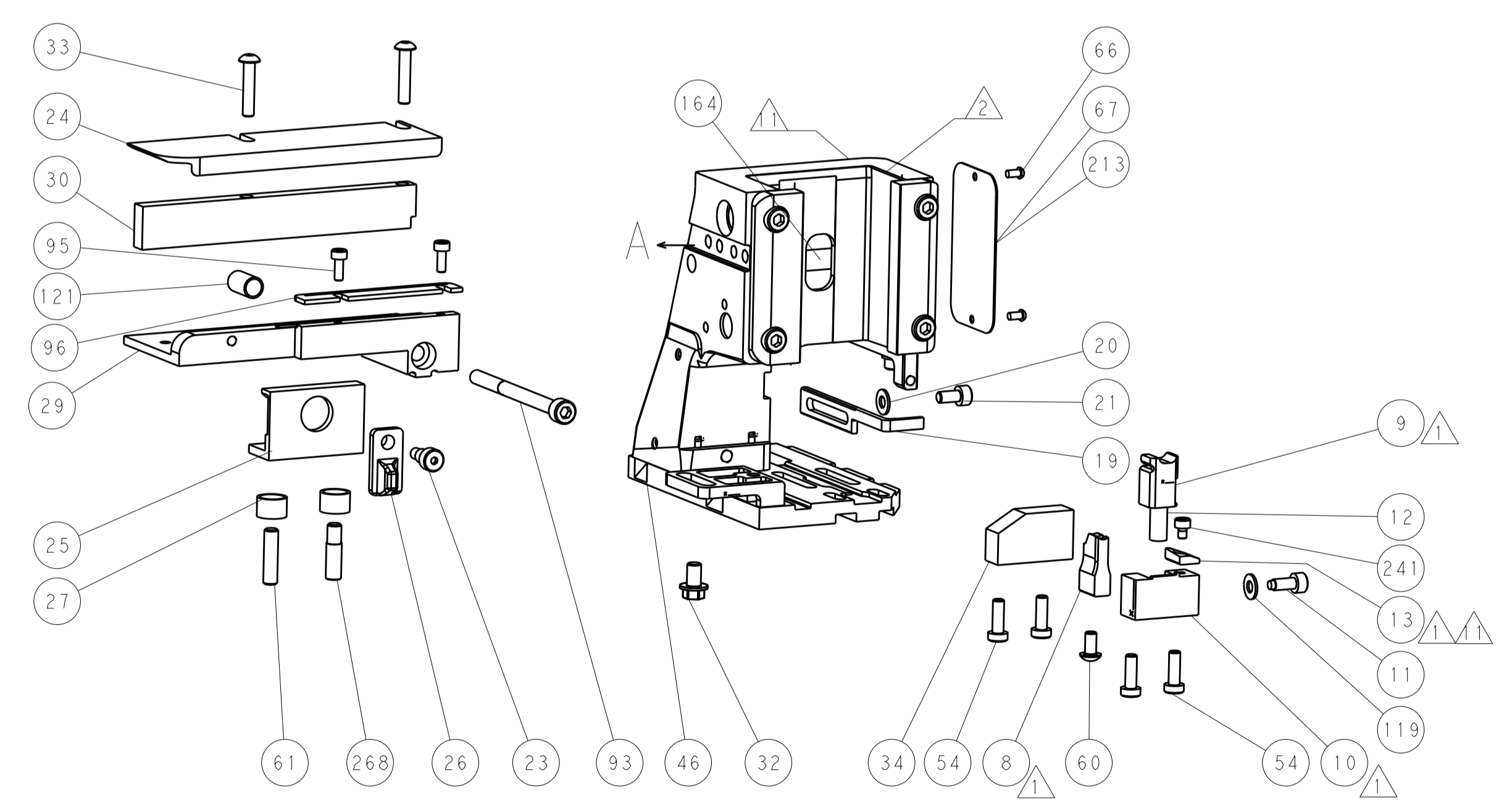
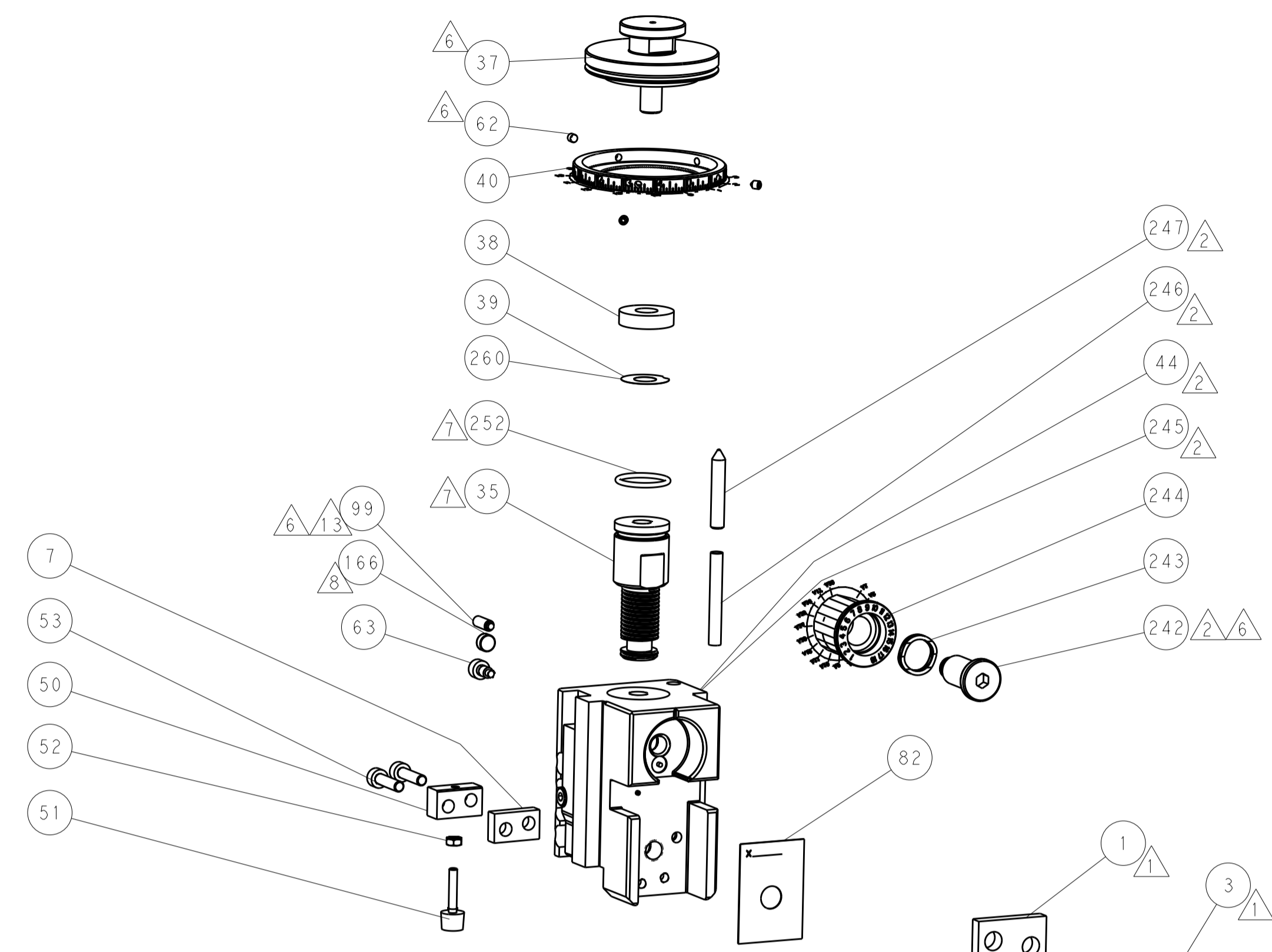
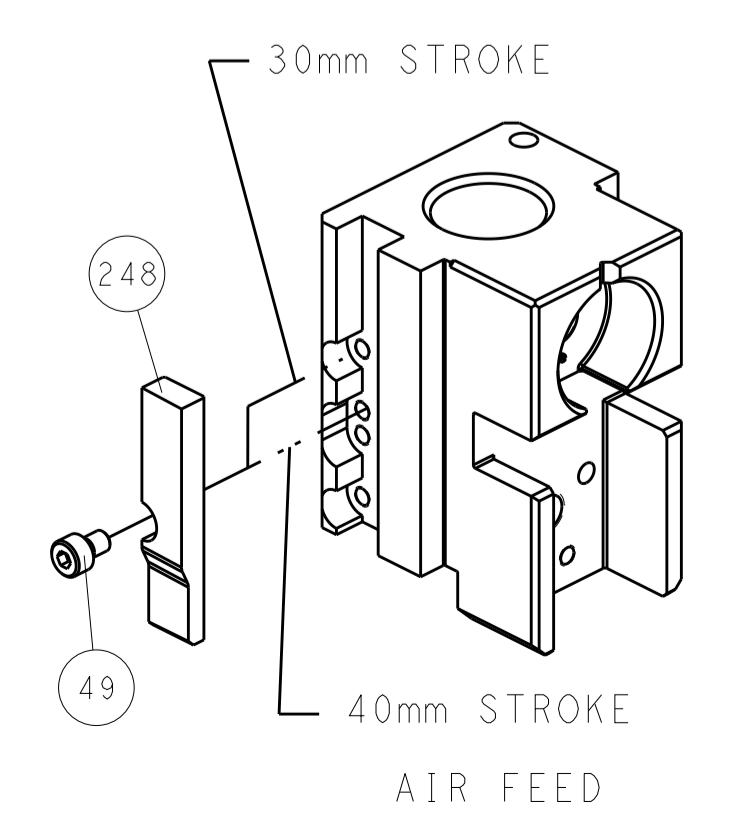

TERMINAL SUPPORT LOCATION

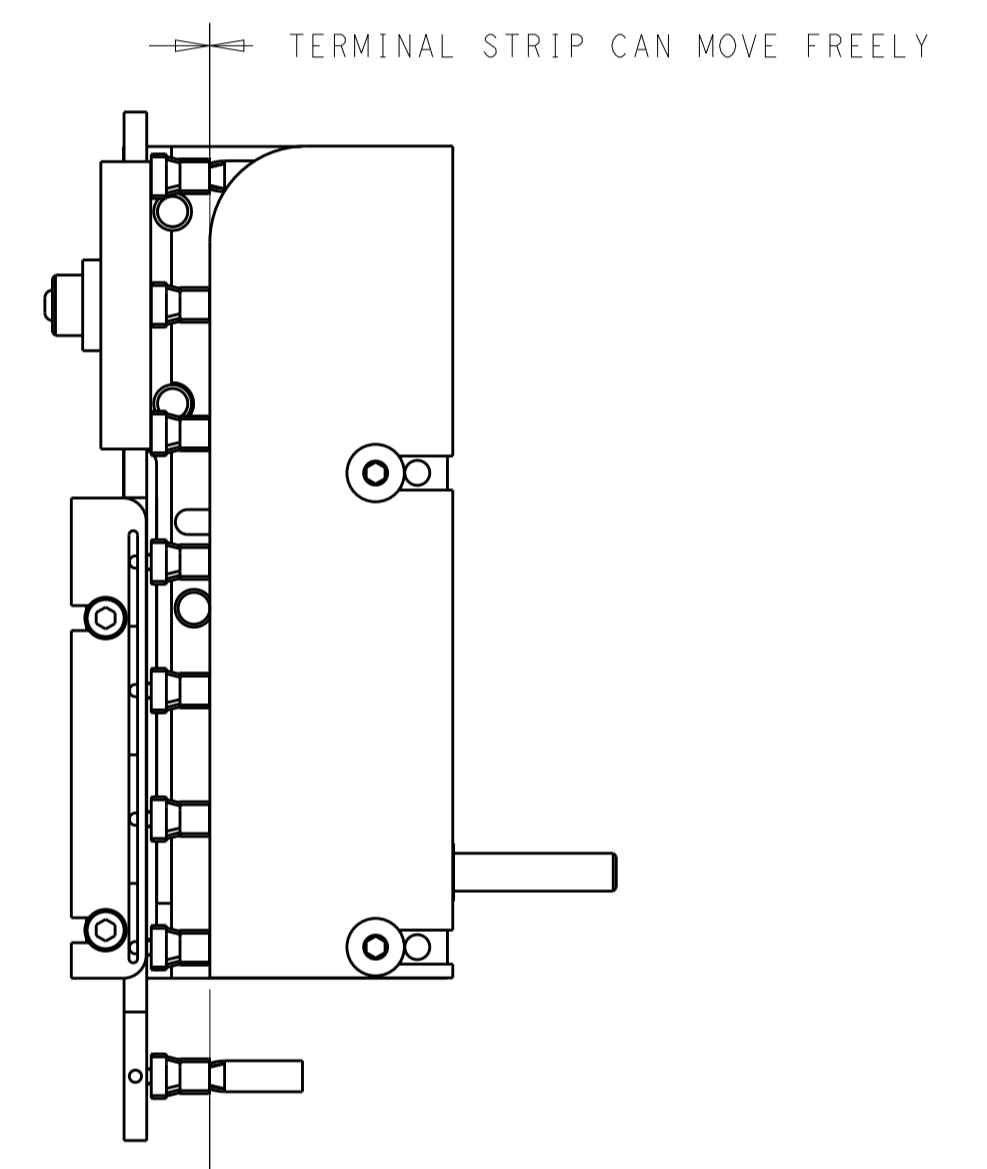

FEED TRACK POSITION

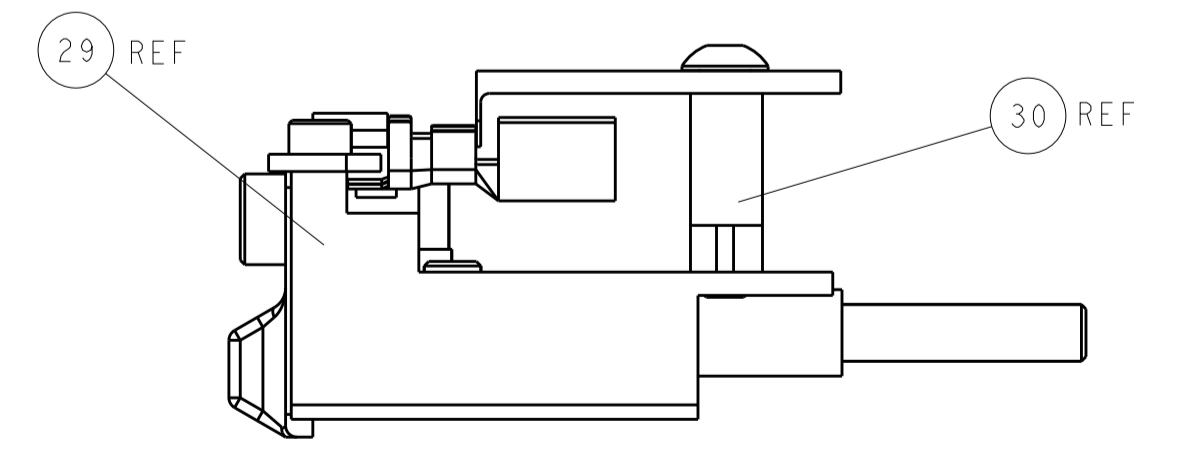

ITEM 30 LOCATED AT REAR HOLES



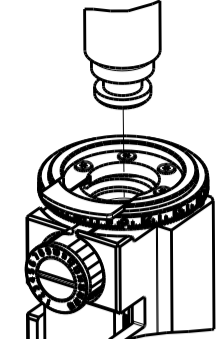

FEED TRACK POSITION GUIDE BY WIRE BARREL

**ATLANTIC VERSION**  
 Shown on sheets 1 of 4 & 2 of 4  
 (Pacific version shown on sheets 3 of 4 & 4 of 4)

DIMENSIONS:		TOLERANCES UNLESS OTHERWISE SPECIFIED:		OWN: R. KNEPPER 18JAN2012		TE Connectivity	
mm	0 PLC	±		CHK: T. ELBIN 18JAN2012	NAME: Ocean Side Feed Applicator		Harrisburg, PA 17105-3608
	1 PLC	±		APVD: M. CLIFFORD 18JAN2012	SIZE: A1		CAGE CODE: 00779
	2 PLC	±		PRODUCT SPEC:	DRAWING NO: 2151551		RESTRICTED TO:
	3 PLC	±		APPLICATION SPEC:	SCALE: 1:2		SHEET 2 OF 4
	4 PLC	±		WEIGHT:	REV: G		
MATERIAL:	FINISH:			Customer Accessible Production Drawing			



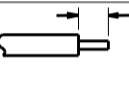







PACIFIC VERSION TERMINATOR INTERFACE ADAPTER	PART NUMBER	REVISION	DESCRIPTION	FEED TYPE	APPLICATOR STYLE CONVERSION CHART						
					CONVERT TO	PART NUMBERS REQUIRED					
	2-2151551-2	G	FINE CRIMP HEIGHT ADJUST	PNEUMATIC	SERVO LATCH PLATE	2119951-1	-	8-2151551-5	1901094-3	-	2168400-6 (QUANTITY 2)
					SMART APPLICATOR	2161326-1	-	8-2151551-4	-	-	
	2-2151551-5	G	FINE CRIMP HEIGHT ADJUST	SERVO LATCH PLATE 	PNEUMATIC FEED	2119950-1	1338685-1	5-18022-5	2119641-2	2119799-1	2063440-1
					-	-	-	-	-	-	
2-2151551-7	G	FINE CRIMP HEIGHT ADJUST	NONE	-	-	-	-	-	-	-	
7-2151551-7	A	CRIMP TOOLING KIT	-	-	-	-	-	-	-	-	

APPLICATOR DATA		
CRIMP	SIZE	TYPE
WIRE	3.30 mm [.130]	F
INSUL	4.06 mm [.160]	F
APPLICATOR INSTRUCTIONS 408-10389 		

TERMINAL DATA: TE TERMINAL		TE CRIMP SPECIFICATION	
TERMINAL NAME: AMP MCP 6.3/4.8 K LITEALUM CONTACT			
WIRE STRIP LENGTH		INSULATION DIAMETER RANGE	
3.40-4.00 mm [.134-.157 IN]		∅ 3.56-3.74mm [.140-.147 IN]	
TERMINAL APPLICATION SPECIFICATION	114-94204	-	-
TERMINALS APPLIED 			
TE TERMINAL	TE TERMINAL	TE TERMINAL	TE TERMINAL
2-2177839-1	2-2177839-3		

WIRE SIZE	CRIMP HEIGHT mm [INCH]	CRIMP HEIGHT REFERENCE SETTING
4.00mm <sup>2</sup>	1.90±0.04 [.0748±.0016]	8.5













-  RECOMMENDED SPARE PARTS
-  GREASE BEARING SURFACES LIGHTLY
- 3. LUBRICATE DAILY PER THE APPLICATOR INSTRUCTION SHEET SUPPLIED WITH THE APPLICATOR.
-  APPLICATOR SPECIFIC DATA TO BE ENTERED INTO BLANK MEMORY CHIP AT ASSEMBLY. SEE BELOW FOR PART NUMBER:  
 PNEUMATIC FEED WITH "SMART APPLICATOR" CONVERSION: 8-2151551-4  
 SERVO FEED WITH "FINE CRIMP HEIGHT ADJUST": 8-2151551-5
- 5. ADJUSTMENT OF THE STRIPPER MAY BE REQUIRED WHEN MOVING THE APPLICATOR BETWEEN BENCH AND LEADMAKER APPLICATIONS.
-  APPLY PART NUMBER 1-23419-5 LOCTITE TO THREADS OF ITEMS 62.  
 APPLY PART NUMBER 2-23419-6 LOCTITE TO THREADS OF ITEMS 99 & 242.
-  GREASE THREADS, GROOVE AND O-RING ON ITEMS 139 & 152.
-  MAGNET MUST BE ORIENTED CORRECTLY IN ORDER TO PROPERLY ACTUATE THE COUNTER.
-  CRIMP HEIGHT REFERENCE SETTING WAS THE SETTING USED WHEN THE APPLICATOR WAS QUALIFIED AT THE FACTORY. ADJUSTMENT MAY BE NECESSARY WHEN RUNNING APPLICATOR IN THE FIELD.
-  TERMINAL PITCH NOT COMPATIBLE WITH MECHANICAL FEED.
-  TO CONVERT THE APPLICATOR TO A NON-CARRIER CUTTING STYLE, REMOVE ITEM 13 AND ATTACH TO THE LOCATION ON BACK SIDE OF THE HOUSING. REFER TO INSTRUCTION SHEET FOR ADDITIONAL INFORMATION.
-  SET THE FINE CRIMP HEIGHT ADJUSTMENT HEAD TO PROPER CRIMP HEIGHT PRIOR TO TIGHTENING/LOCKING THE BRASS TIP SET SCREW, ITEM 99, AGAINST THE ADJUSTMENT BOLT THREADS.
- 13. APPLICATOR TO BE USED IN CONJUNCTION WITH LEADMAKER INTIGRATION KIT, P/N 2280475-1 FOR CLAMPING AND SENSING OF FEED TRACK.

**\*WARNING**  
 ON INSTALLATION, SET WIRE DISC, ITEM 40 TO LARGEST WIRE SIZE SETTING. USE OF SETTINGS BELOW MINIMUM REQUIRED CRIMP HEIGHT SETTING WILL CAUSE DAMAGE TO CRIMP TOOLING.

-	1	1	1	2-1722335-1	THREAD BOLT GEWINDEBOLZEN	268
-	1	1	1	2119782-1	FINE ADJUST HEAD ASM, PACIFIC STYLE	251
-	-	-	1	2119640-1	PUSH ROD, AIR FEED	250
-	-	-	1	2079988-1	BUSHING, LCH5-12, MISUMI	249
-	1	1	1	1-22279-3	SPRING, COMPRESSION	246
-	1	1	1	2119082-4	CAM, SNAIL, INSULATION ADJUSTMENT	244
-	1	1	1	2079764-1	WASHER, WAVE SPRING, CREST-TO-CREST	243
-	1	1	1	2119083-1	RETAINER, INSULATION DIAL	242
-77	-27	-25	-22	PART NO	DESCRIPTION	ITEM NO

**PACIFIC VERSION**  
 Shown on sheets 3 of 4 & 4 of 4  
 (Atlantic version shown on sheets 1 of 4 & 2 of 4)

SET UP GAUGE	LOC	DIST	REVISIONS			
2119599-1	A	66	REV	DATE	BY	APPV
-	-	-	1	SEE SHEET 1	-	-

-	1	1	1	7-18023-7	SCR, SKT HD CAP M3 X 4.0	241
-	-	2	-	2168400-6	SHCS, LOW HEAD, RoHS, M5 X 16	240
-	-	-	1	2063440-1	AIR FEED MODULE	238
-	-	-	1	2119740-2	TAG, IDENTIFICATION	213
-	-	-	1	1901094-3	SPACER, FEEDER	198
-	-	-	2	21045-3	RING, RETAIN, EXTERN, 3/16 CRESCENT	172
	1	1	1	994969-1	MAGNET, RARE EARTH HIGH ENERGY	166
-	REF	REF	REF	994970-2	COUNTER, MAGNETIC	164
-	-	-	1	240638-1	SPRING, FEED FINGER	163
	1	1	1	8-21084-1	O-RING, .801 ID, .070 DIA. MAT.	152
-	-	-	1	2119641-2	FEED CAM, AIR FEED	151
-	1	1	1	2119798-2	DETENT PIN	145
-	1	1	1	2079383-8	SCR, BHSC, RoHS (M4 X 16)	144
-	4	4	4	2168400-5	SHCS, LOW HEAD, RoHS, M4 X 20	143
-	1	1	1	2-2119656-4	APPLICATOR BASIC ASSEMBLY, SF	141
-	1	1	1	2119650-1	RAM, ASIAN STYLE, SIDE FEED	140
	1	1	1	2119092-2	BOLT, ADJUSTMENT	139
-	-	-	1	3-23627-7	PIN, RETAIN, GRVD, 3/16 X .854	137
-	-	-	1	2119799-1	HOLDER, FEED FINGER, AF	136
-	-	REF	-	SEE NOTE 4	MEMORY CHIP, PROGRAMMED	135
-	-	1	-	1633743-1	SERVO FEED LATCH ASM	133
-	1	1	1	1-22281-8	SPRING, COMPRESSION	121
-	1	1	1	1-18028-2	WASHER, FLAT, REG M4	119
-	-	REF	-	2119944-1	FEED FINGER ASSEMBLY, SF	117
	1	1	1	2256587-1	SCR, SET, SOFT TIP, M4	99
-	1	1	1	1-690438-0	FRONT STRIP GUIDE	96
-	2	2	2	2168083-1	SCR, SKT HD CAP, RoHS, M3 X 8.0	95
-	1	1	1	2168083-6	SCR, SKT HD CAP, RoHS, M5 X 65	93
-	1	1	1	455888-3	SPACER, CRIMPER	82
-	1	1	1	2119956-1	DOCUMENTATION PACKAGE	71
-	1	-	1	2119740-1	TAG, IDENTIFICATION	67
-	2	2	2	2168078-1	SCREW, DRIVE, RH, RoHS, 2 x .188	66
-	1	1	1	2119793-1	LIMITER, ADJUSTMENT BOLT	63
	3	3	3	992763-5	SCR, SET, SOC, CONE POINT, M3 x 4.0	62
-	1	1	1	2-18032-5	SCR, SET, FLT POINT M5 X 20.0	61
-	-	-	1	5-18022-5	SCR, HEX HD CAP, M4 X 6.0	59
-	-	-	1	1338685-1	PAWL, FEED	56
-	2	2	2	2168083-8	SCR, SKT HD CAP, RoHS, M4 X 16	53
-	1	1	1	5018030-1	NUT, HEX, REG, RoHS, M3	52
-	1	1	1	811242-5	BUMPER, HOLD DOWN	51
-	1	1	1	690753-2	SPACER, TONKER	50
-	-	-	1	18023-9	SCR, SKT HD CAP M4 X 6.0	49
-	1	1	1	2079383-7	SCR, BHSC, RoHS (M8 X 25)	41
-	1	1	1	2119645-1	DISC, NUMBERED FA WIRE ADJUSTMENT	40
-	1	1	1	2119957-1	APPLICATOR SHIM PACK	39
-	1	1	1	2119644-2	RAM WASHER, PRECISION	38
-	1	1	1	1-1752356-2	SUPPORT, TERMINAL	34
-	2	2	2	2079383-5	SCR, BHSC, RoHS (M4 X 20)	33
-	1	1	1	2161328-1	HEX HEAD, FLANGED, M5 x 8mm LONG	32
-	1	1	1	1320908-7	SPACER, STRIP GUIDE	30
-	1	1	1	1901086-1	PLATE, STRIP GUIDE	29
-	1	1	1	1-455888-0	SPACER, CRIMPER	28
-	2	2	2	22283-1	SPRING, COMPRESSION	27
-	1	1	1	356835-1	LEVER, DRAG RELEASE	26
-	1	1	1	1803142-1	DRAG, TERMINAL	25
-	1	1	1	1320928-2	STRIP GUIDE	24
-	1	1	1	980371-4	SCR, SKT HD SHLDR 5.0 DIA X 6.0	23
-	1	1	1	2168083-2	SCR, SKT HD CAP, RoHS, M4 X 8.0	21
-	1	1	1	1-18028-2	WASHER, FLAT, REG M4	20
-	1	1	1	690472-2	STRIPPER	19
	1	1	1	2119806-1	INSERT, SHEAR	13
-	1	1	1	3-22280-3	SPRING, COMPRESSION	12
-	1	1	1	1-356885-5	STOP, SHEAR	11
	1	1	1	2119805-1	SHEAR HOLDER, FRONT	10
	1	1	1	462006-6	FLOATING SHEAR, FRONT	9
	1	1	1	2161316-2	ANVIL, COMBINATION	8
-	1	1	1	2-240641-9	SPACER	7
-	-	-	-	-	-	6
-	1	1	1	1-1722335-0	SHEAR DEPRESSOR ASSEMBLY	5
-	1	1	1	5-238011-2	BLOCK, CRIMPER SPACER	4
	1	1	1	1722335-8	CRIMPER, INSULATION F	3
-	-	-	-	-	-	2
	1	1	1	2217302-2	CRIMPER, WIRE, CONICAL BLEND	1
-77	-27	-25	-22	PART NO	DESCRIPTION	ITEM NO

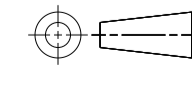
DIMENSIONS:		TOLERANCES UNLESS OTHERWISE SPECIFIED:		DATE		NAME	
mm	0 PLC ±	1 PLC ±	2 PLC ±	18JAN2012	R. KNEPPER	18JAN2012	T. ELBIN
	3 PLC ±	4 PLC ±	ANGLES ±	18JAN2012	M. CLIFFORD	18JAN2012	APVD
MATERIAL	FINISH	WEIGHT	SCALE	Customer Accessible Production Drawing			
			1:2	SHEET 3 OF 4			

LOC		DIST		REVISIONS			
A	66	P	LTN	DESCRIPTION	DATE	OWN	APVD
		-		SEE SHEET 1			

### FEED TYPE PNEUMATIC

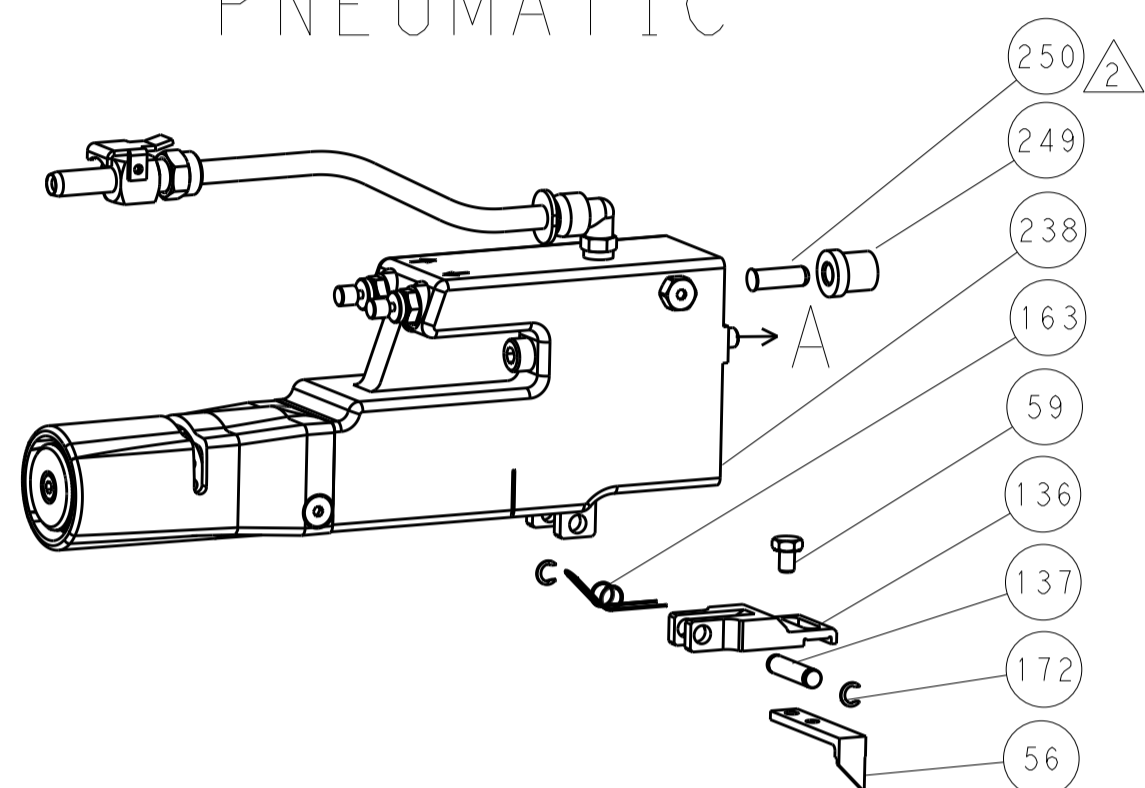

### SERVO LATCH PLATE

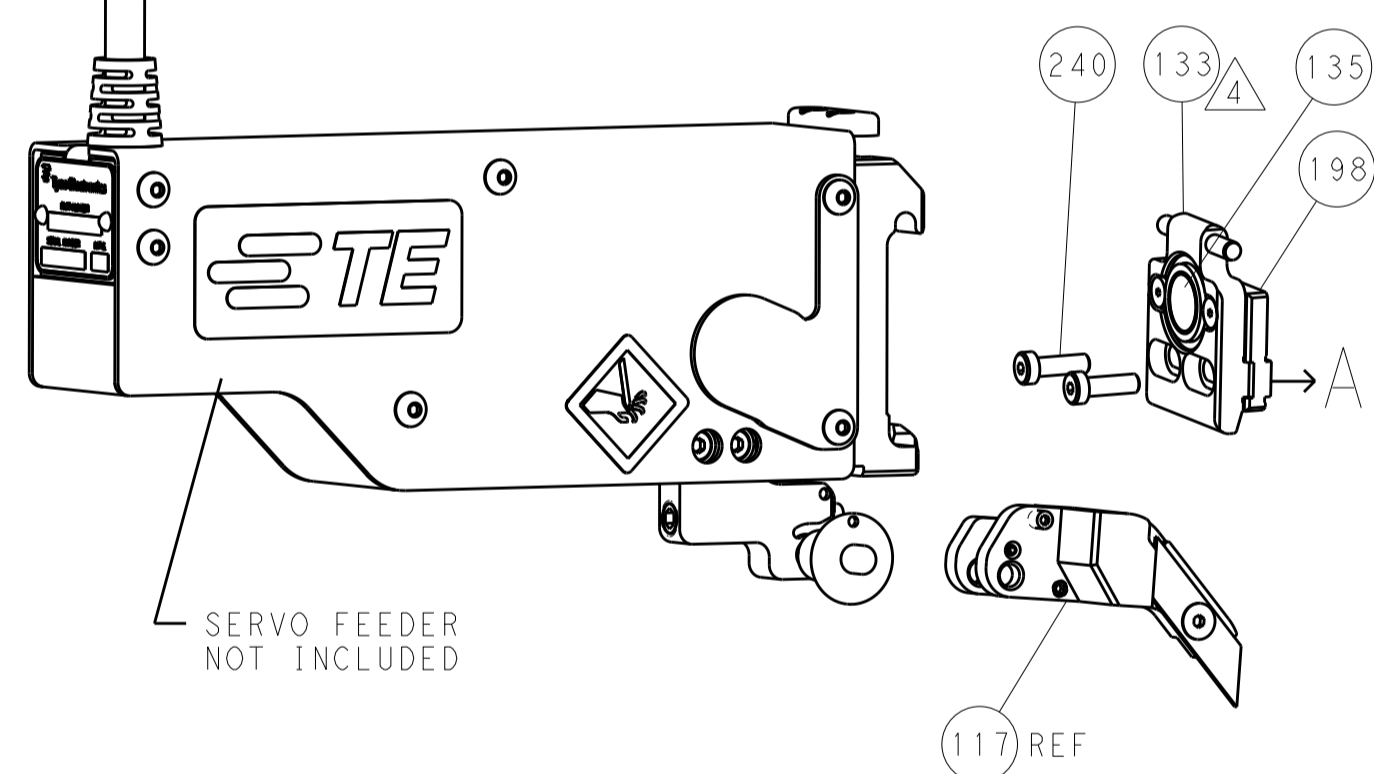

### CAM POSITIONS

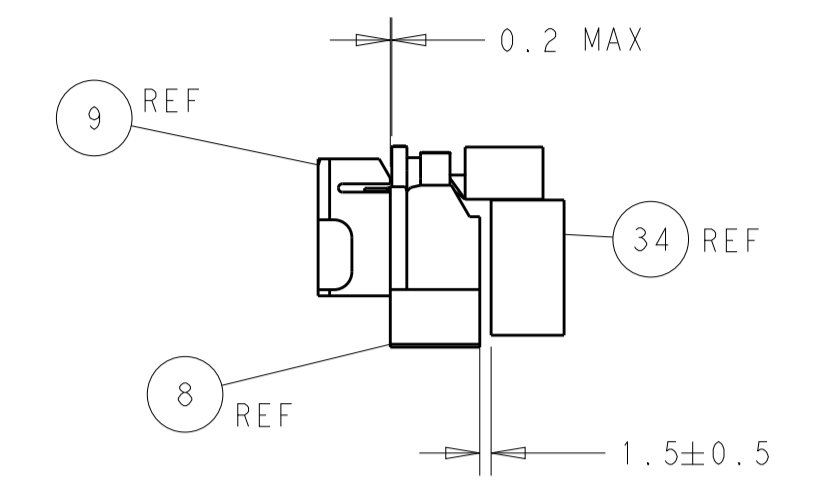
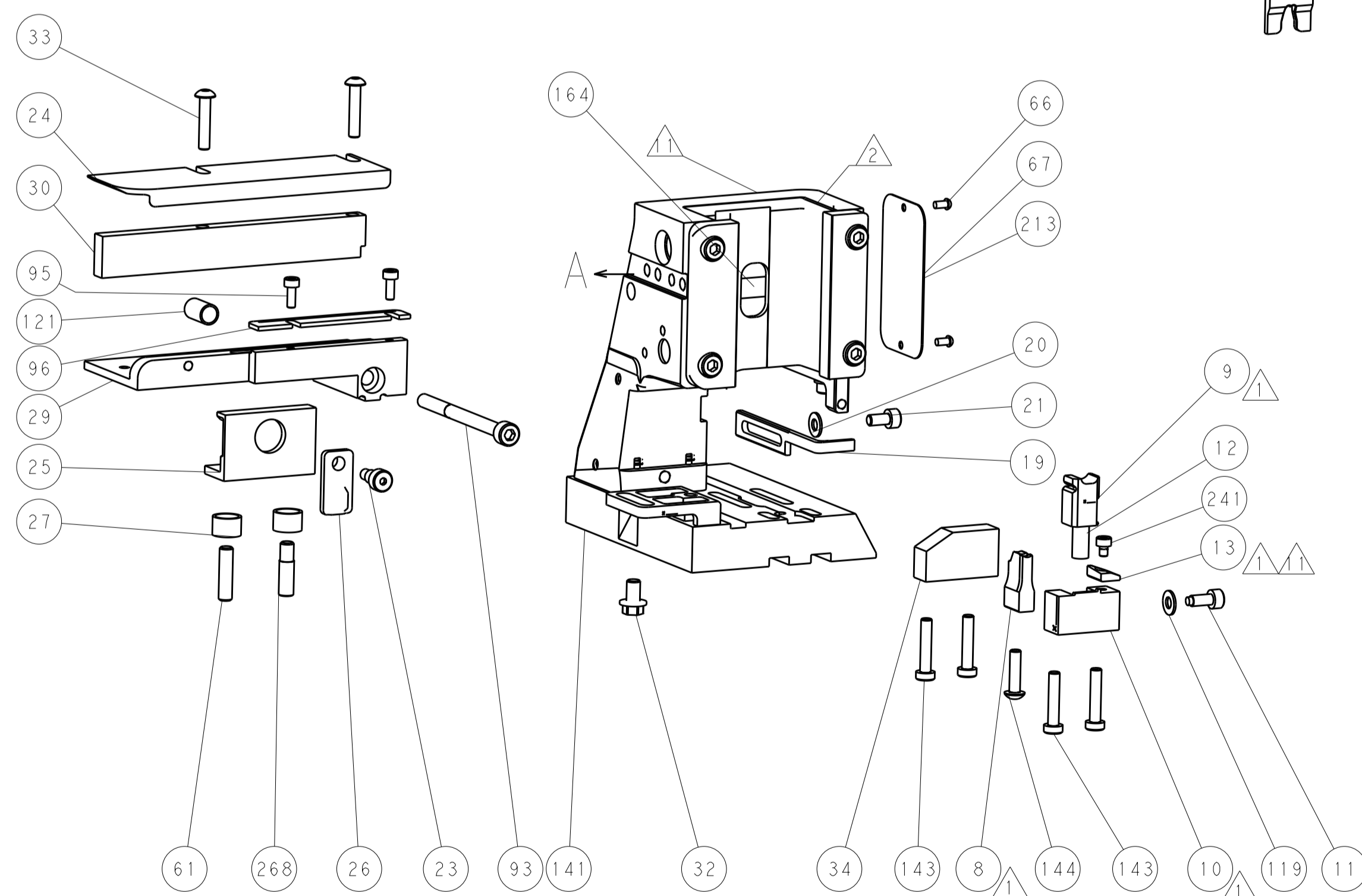
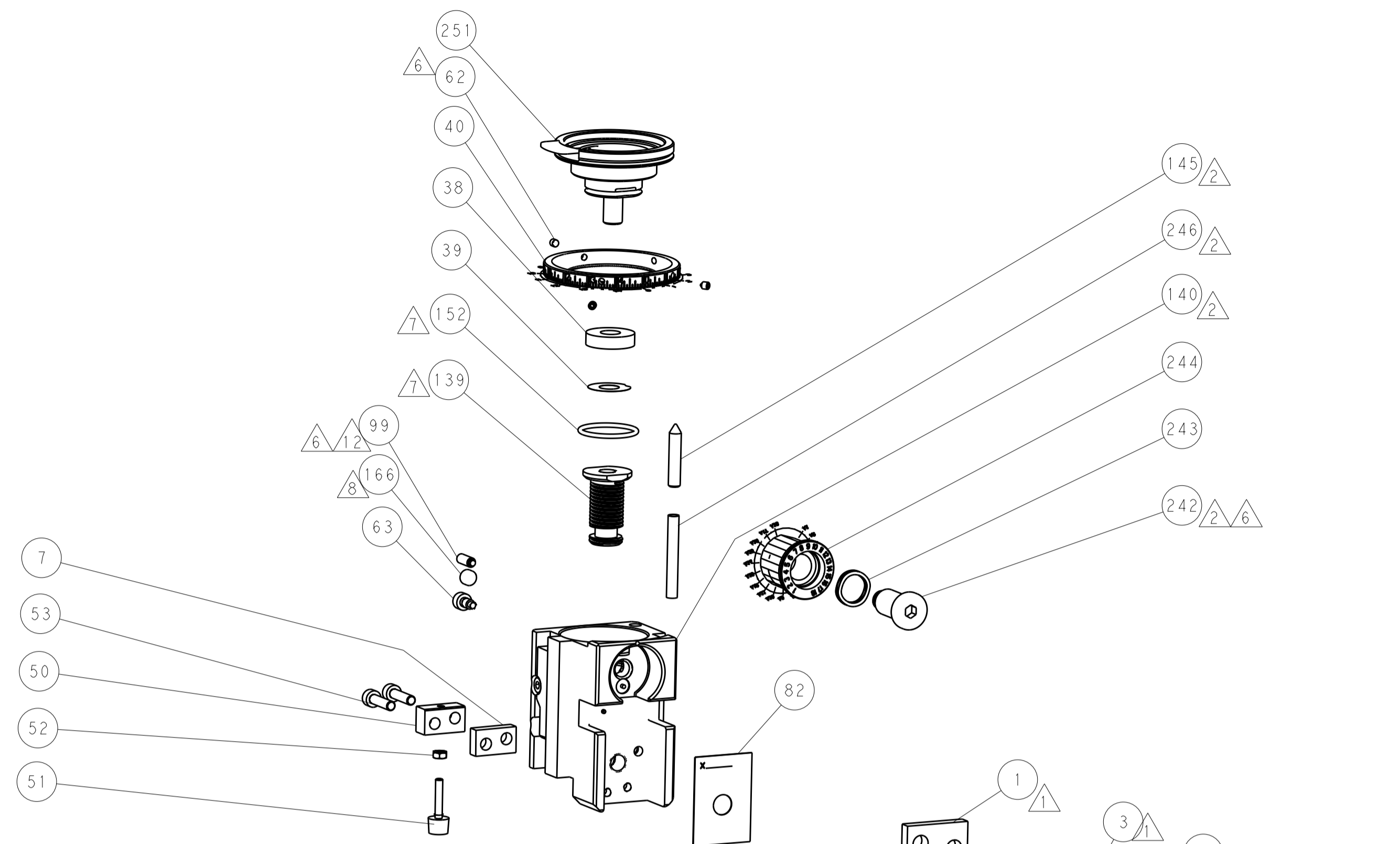
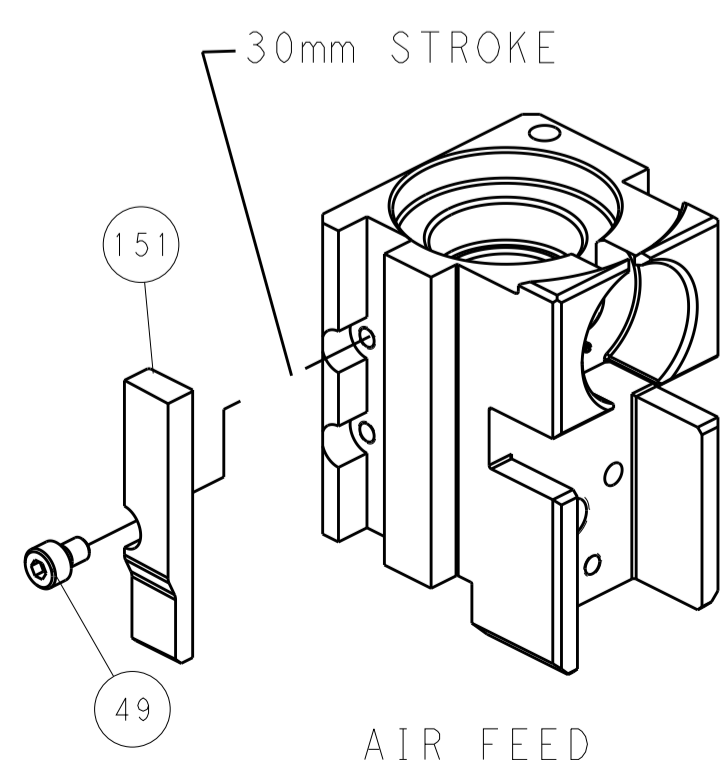

TERMINAL SUPPORT LOCATION

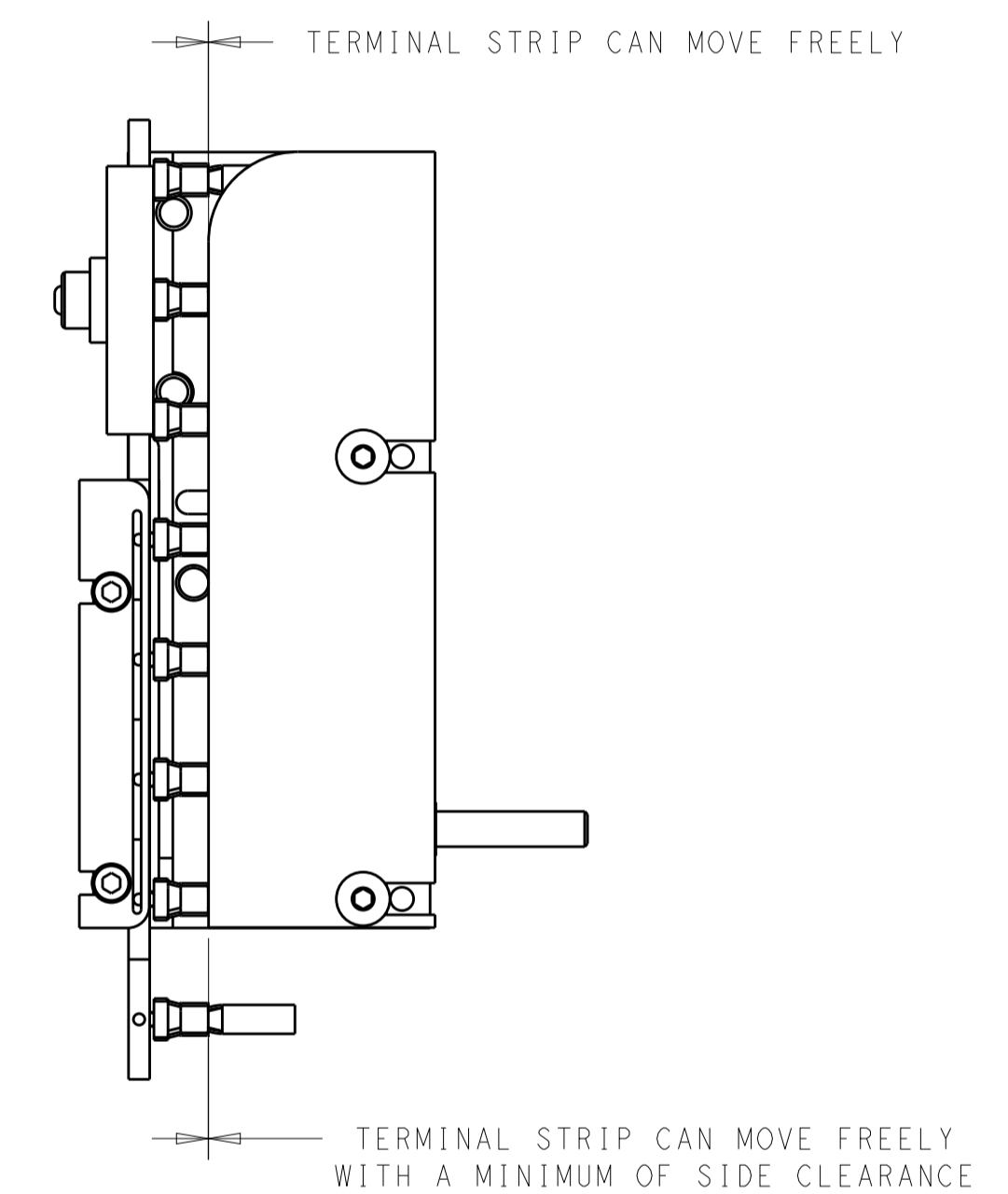

FEED TRACK POSITION

ITEM 30 LOCATED AT REAR HOLES

FEED TRACK POSITION GUIDE BY WIRE BARREL

**PACIFIC VERSION**  
 Shown on sheets 3 of 4 & 4 of 4  
 (Atlantic version shown on sheets 1 of 4 & 2 of 4)

<small>THE DRAWING IS UNPUBLISHED. RELEASED FOR PUBLICATION. IT IS THE BUYER'S RESPONSIBILITY TO OBTAIN THE LATEST REVISIONS. THIS DRAWING IS THE PROPERTY OF TYCO ELECTRONICS CORPORATION. IT IS TO BE USED ONLY FOR THE PURCHASE AND INSPECTION OF THE PARTS SPECIFIED HEREIN. IT IS NOT TO BE REPRODUCED OR COPIED IN ANY MANNER WITHOUT THE WRITTEN PERMISSION OF TYCO ELECTRONICS CORPORATION.</small>		DWN: R. KNEPPER 18JAN2012 CHK: T. ELBIN 18JAN2012 APVD: M. CLIFFORD 18JAN2012	TE Connectivity Harrisburg, PA 17105-3608
DIMENSIONS: mm TOLERANCES UNLESS OTHERWISE SPECIFIED: 0 PLC ± 1 PLC ± 2 PLC ± 3 PLC ± 4 PLC ± ANGLES ±		NAME: Ocean Side Feed Applicator SIZE: A1 CAGE CODE: 00779 DRAWING NO: 2151551	RESTRICTED TO: G
MATERIAL: - FINISH: -		WEIGHT: - SCALE: 1:2 SHEET: 4 OF 4 REV: G	Customer Accessible Production Drawing