

Not Recommended for New Design



AP451

2 Channel Linear Controller with Independent Enable Function

■ Features

- 2 channel linear control Circuitries
- Operating voltage can be up to 18V
- Under Voltage Lockout (UVLO) Protection
- Current limit external BJT only
- Independent enables function
- Low ESR output capacitor (Multi-layer chip capacitor (MLCC)) application
- Adjustable output voltage by external resisters
- 0.8V voltage reference Output
- NPN or N-channel MOSFET driving capability
- 8-pin SOP, PDIP **Pb-Free** packages

■ Applications

- LCD Monitor/TV
- XDRom, XDSL Product
- M/B, VGA

■ Pin Assignment

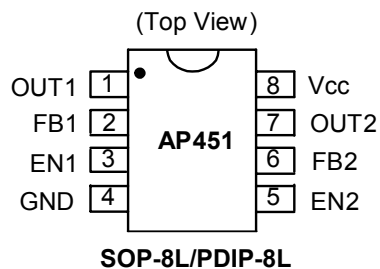

■ General Description

The AP451 integrates two channel linear controllers into a single chip, mainly designs for power-supply regulator. All the functions included an on-chip 0.8V reference output, an error amplifier, UVLO, current limit. During low VCC situation, the UVLO makes sure that the outputs are off until the internal circuit is operational normally.

■ Pin Descriptions

Pin Name	Pin No.	Description
OUT1	1	Linear Controller CH1output
FB1	2	Channel 1 Voltage Feedback
EN1	3	Channel 1 Enable Pin
GND	4	Signal Ground
EN2	5	Channel 2 Enable Pin
FB2	6	Channel 2 Voltage Feedback
OUT2	7	Linear Controller CH2 output
Vcc	8	Supply Voltage

■ Ordering Information

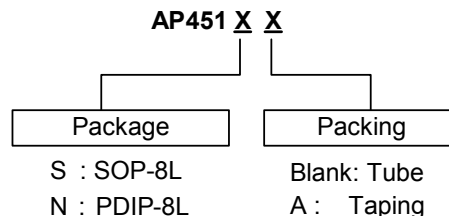

Not Recommended for New Design



AP451

2 Channel Linear Controller with Independent Enable Function

■ Block Diagram

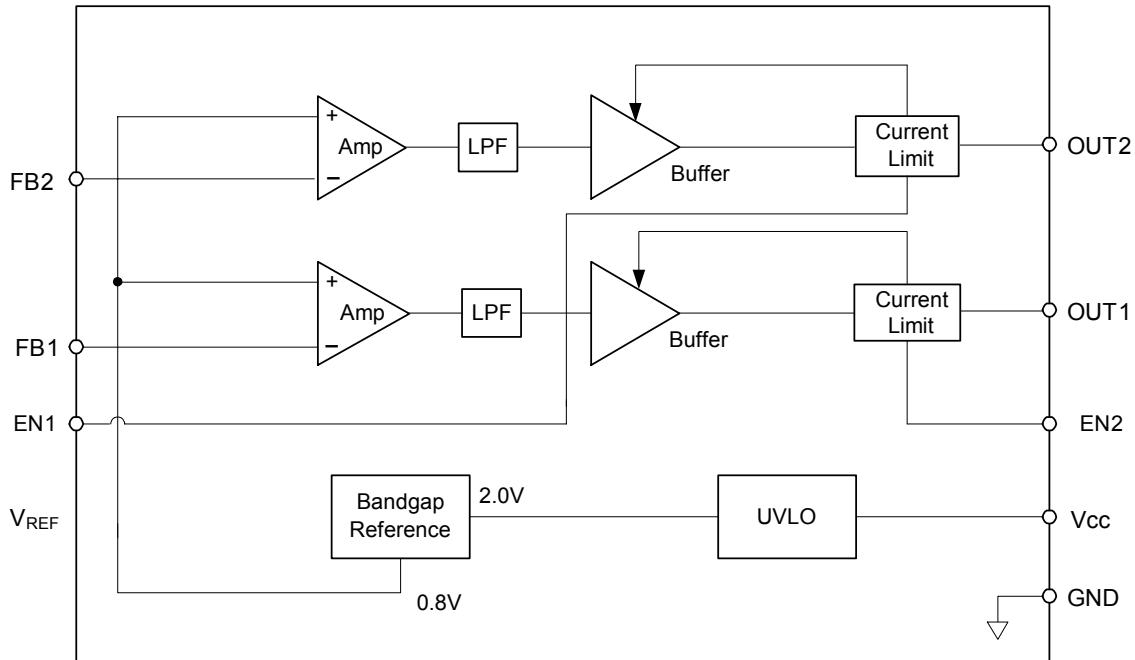

■ Absolute Maximum Ratings

Symbol	Parameter	Rating	Unit
V_{CC}	Supply Voltage	19	V
V_{EN}	Enable Pin Voltage	18	V
V_{O1} / V_{O2}	CH1 / CH2 Linear Driver Voltage to Ground	$-0.3 \leq V \leq 18$	V
T_{OP}	Operating Temperature Range	-20 to +85	$^{\circ}C$
T_{ST}	Storage Temperature Range	-65 to +150	$^{\circ}C$
T_{LEAD}	Lead Temperature 1.6 mm (1/16 inch) from Case for 10 Seconds	260	$^{\circ}C$

■ Recommended Operating Conditions

Symbol	Parameter	Min.	Max.	Unit
V_{CC}	Supply Voltage	3.0	18	V
V_{EN}	Enable Pin Voltage	According to V_{CC}		V
V_{O1} / V_{O2}	CH1 / CH2 Linear Driver Voltage to Ground	-	$V_{CC}-1.5$	V
I_{FB}	Current into Feedback Terminal	-	45	μA
R_F	Feedback Resistor	100	-	$k\Omega$
T_{OP}	Operating Free-air Temperature	-20	85	$^{\circ}C$

Not Recommended for New Design



AP451

2 Channel Linear Controller with Independent Enable Function

■ Electrical Characteristics (T_A=25°C, V_{CC}=6V)

Reference (REF)

Symbol	Parameter	Conditions	Min.	Typ.	Max.	Unit
V _{OUT1/2}	V _{O1} / V _{O2} Connect to FB1 / FB2		0.784	0.800	0.816	V
	Output Voltage Change with Temperature	T _A = -20°C ~ 25°C	-	-0.1	±1	%
		T _A = 25°C ~ 85°C	-	-0.2	±1	%

Under voltage lockout (UVLO)

V _{UT}	Upper Threshold Voltage (V _{CC})	I _{O(REF)} = 0.1mA T _A = 25°C	-	2.1	-	V
V _{LWT}	Lower Threshold Voltage (V _{CC})		-	2.0	-	V
V _{HT}	Hysteresis (V _{CC})		-	100	-	mV

Output section

I _{CL1}	CH1 Current Limit	V _{CC} =5V, V _{NOUT2} =V _{FB2} =0V	25	-	-	mA
I _{CL2}	CH2 Current Limit	V _{CC} =5V, V _{NOUT3} =V _{FB3} =0V	25	-	-	mA

Enable function

V _{IH}	EN Pin Logic Input Threshold	High (regulator ON)	2.0	1.3	-	V
V _{IL}	Voltage for EN1/2	Low (regulator OFF)	-		0.6	V
I _{IH}	EN pin Logic Input Current for EN1/2	High (regulator ON)	-	10	-	µA
I _{IL}		Low (regulator OFF)	-	-10	-	µA

Total device

I _{CCA}	Average Supply Current		-	4	6	mA
I _{SD}	Shutdown Current		-	180	500	µA

Thermal Resistor

θ _{JA}	Thermal Resistor Junction to Ambient	SOP8	-	120	-	°C/W
		PDIP8	-	90	-	°C/W

■ Typical Application Circuit

(1) MOSFET

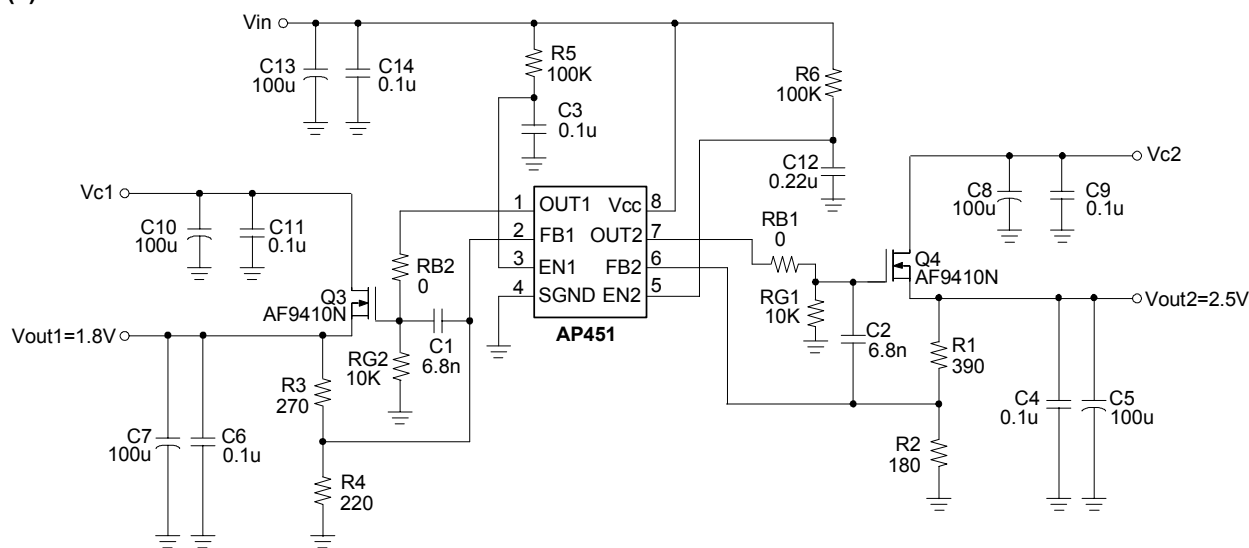

$$V_{out1} = V_{FB1} \times \left(1 + \frac{R3}{R4} \right); \quad V_{out2} = V_{FB2} \times \left(1 + \frac{R1}{R2} \right)$$

R1 and R3=180~2KΩ



2 Channel Linear Controller with Independent Enable Function

■ Typical Application Circuit

(2) BJT

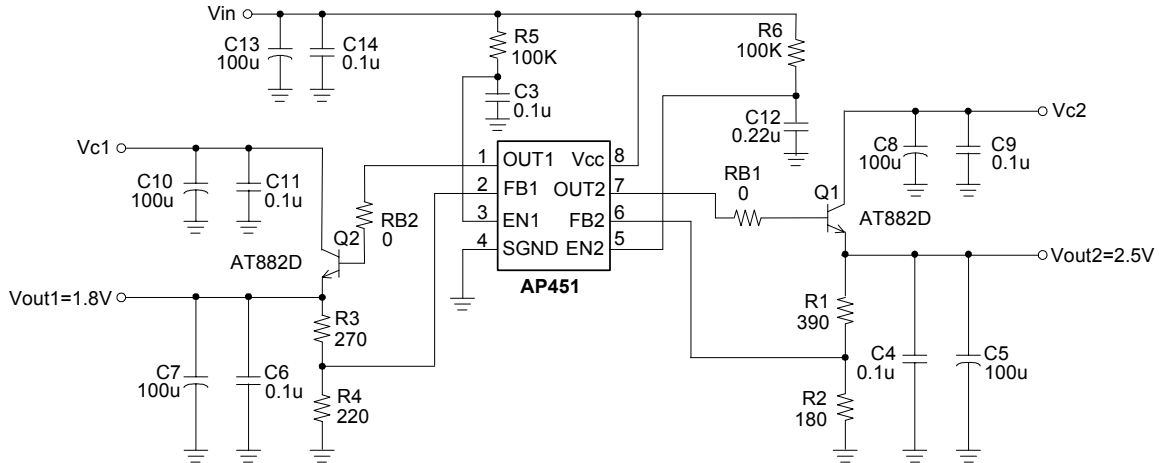

(3) BJT with MLCC

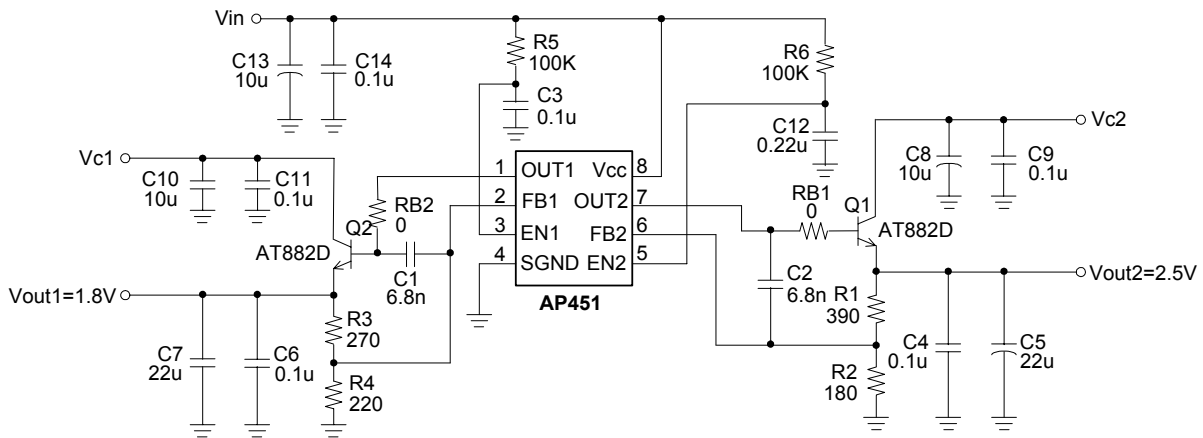

(4) MOSFET with MLCC

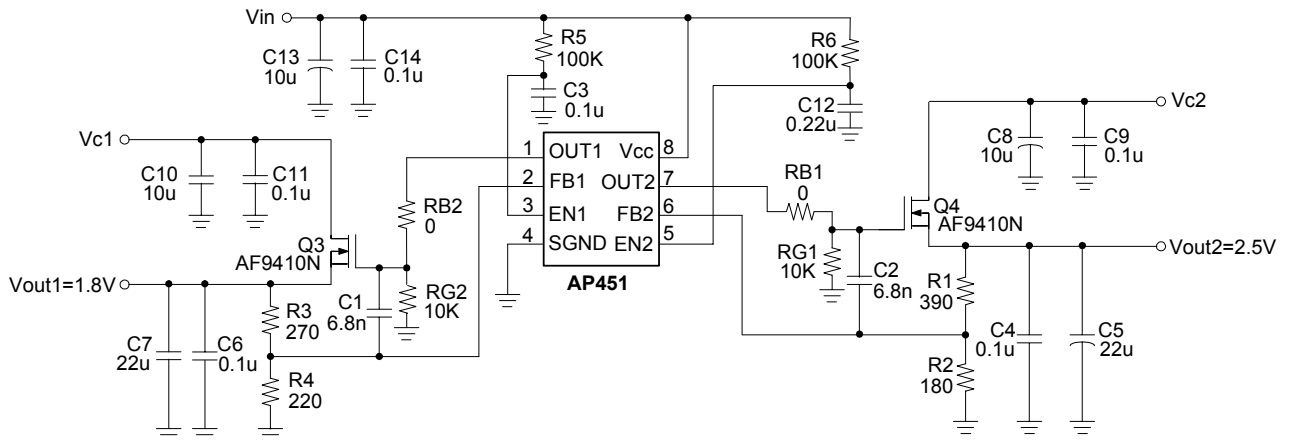

Not Recommended for New Design



AP451

2 Channel Linear Controller with Independent Enable Function

■ Typical Characteristics

Line Regulation
(BJT(882): $V_{cc}=V_{in}$, V_{c1} & $V_{c2}=3.3V$, $I_{out}=0.01A$)

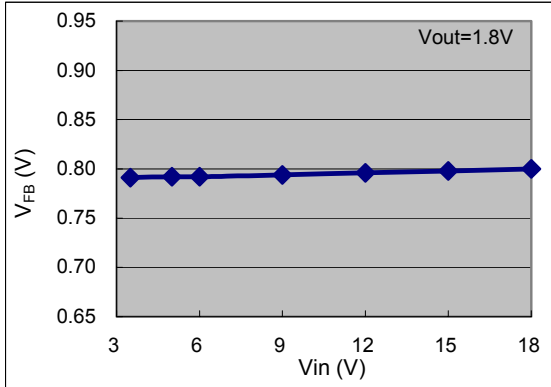

Line Regulation
(BJT(882): $V_{cc}=V_{in}$, V_{c1} & $V_{c2}=3.3V$, $I_{out}=0.01A$)

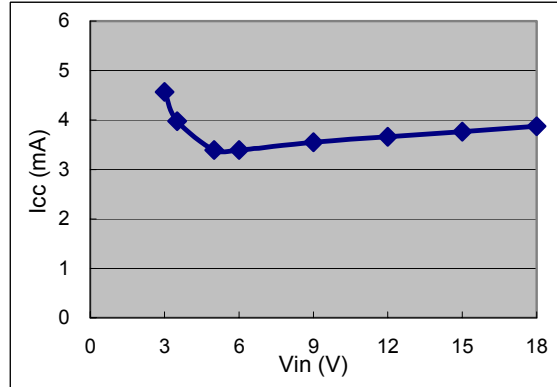

Line Regulation
(BJT(882): $V_{cc}=V_{in}$, V_{c1} & $V_{c2}=3.3V$, $I_{out}=0.01A$)

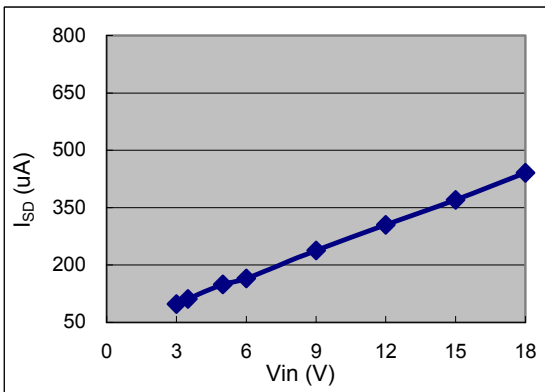

Temperature v.s. V_{FB}
(MOS(AF9410N): $V_{cc}=6V$; V_{c1} & $V_{c2}=3.3V$;
 $V_{out1}=1.8V$, $V_{out2}=2.5V$, $I_{out1\&2}=10mA$)

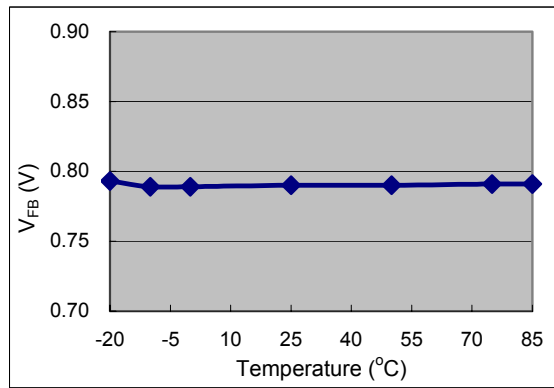

Temperature v.s. I_{CC}
(MOS(AF9410N): $V_{cc}=6V$; V_{c1} & $V_{c2}=3.3V$;
 $V_{out1}=1.8V$, $V_{out2}=2.5V$, $I_{out1\&2}=10mA$)

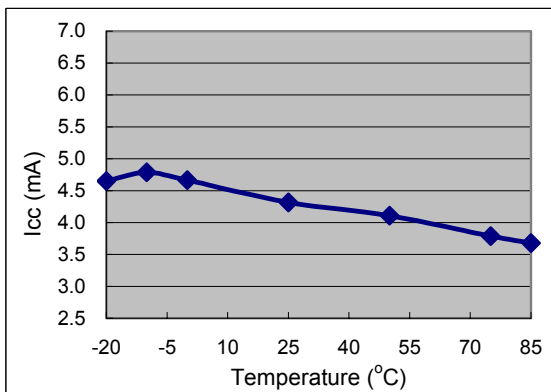

Temperature v.s. I_{SD}
(MOS(AF9410N): $V_{cc}=6V$; V_{c1} & $V_{c2}=3.3V$;
 $V_{out1}=1.8V$, $V_{out2}=2.5V$, $I_{out1\&2}=10mA$)

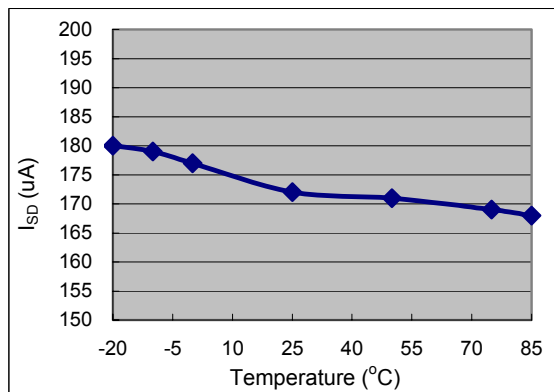

Not Recommended for New Design



AP451

2 Channel Linear Controller with Independent Enable Function

■ Typical Characteristics(Continued)

Vout Ripple
(Vcc=6V; Vc1&Vc2=3.3V; Vout1=1.8V, Vout2=2.5V,
Iout1&Iout2=1A, Vripple1=8mV, Vripple2=8mV)

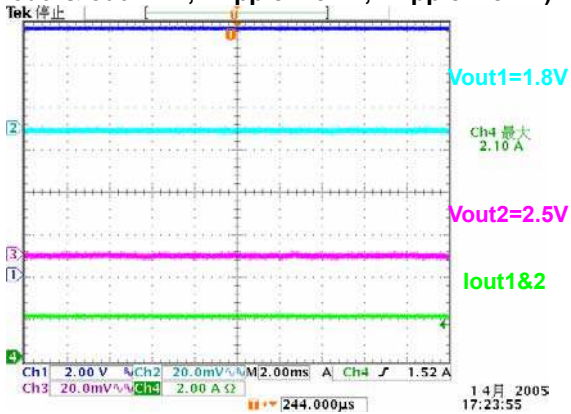

Power Transient Test
(Use BJT(882)+Cout=220uF(AL)
Vcc=6V; Vc=3.3V; Vout1= 1.8V, Iout1=0A~2A)

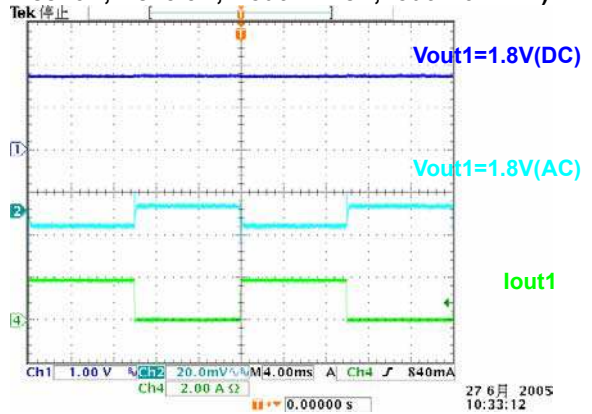

Power Transient Test
(Use MOS(AF9410N)+220uF (AL)
Vcc=6V; Vc=3.3V; Vout1= 1.8V, Iout1=0A~2A)

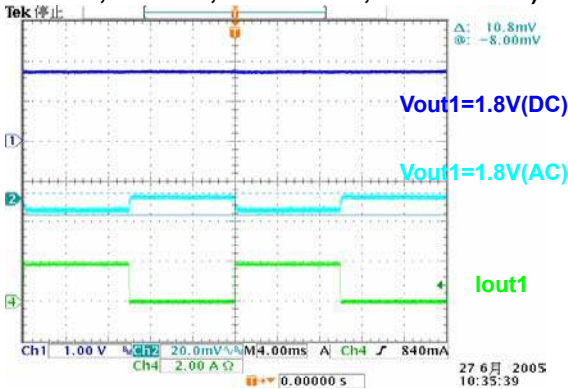

Not Recommended for New Design



AP451

2 Channel Linear Controller with Independent Enable Function

■ Typical Characteristics (with MLCC)

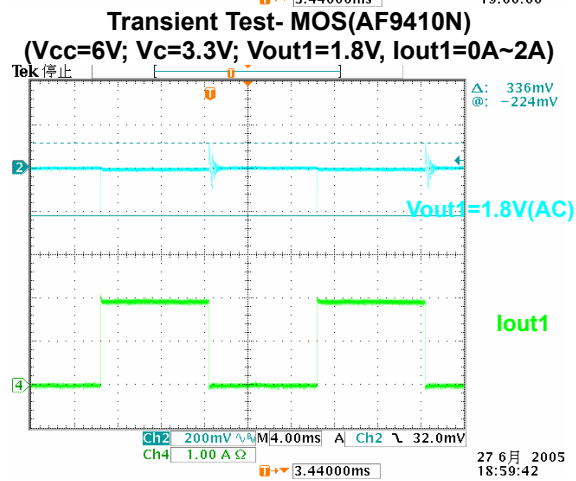
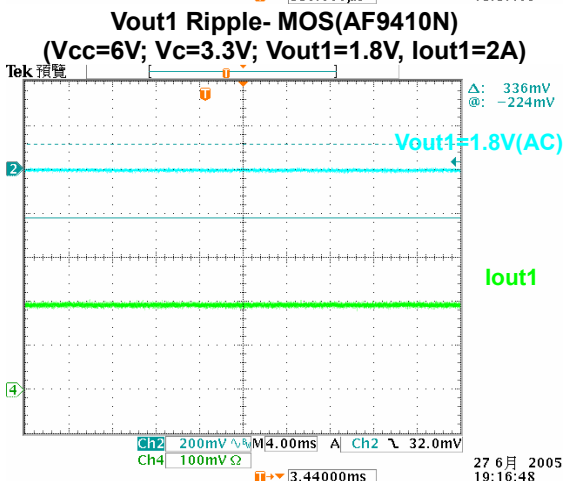
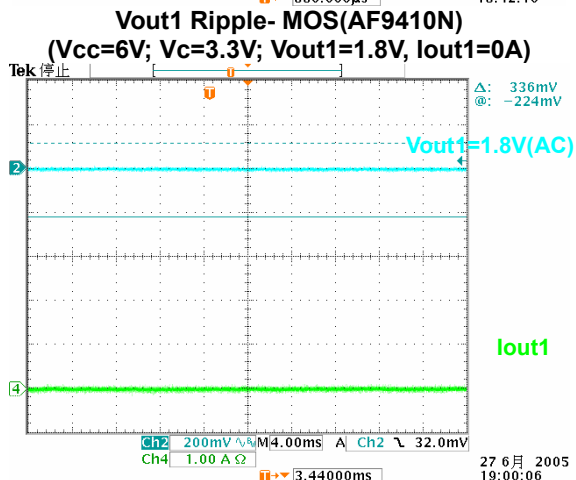
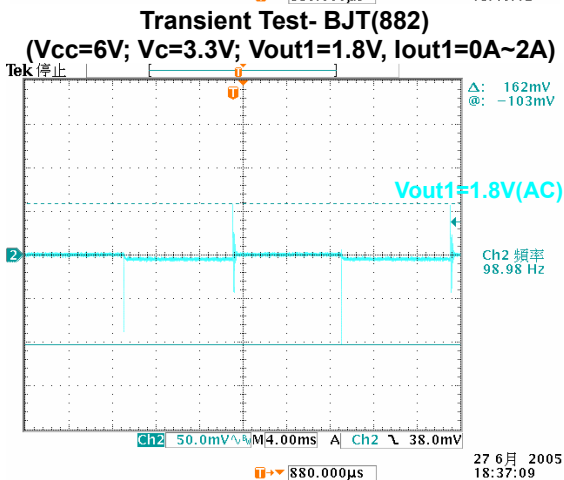
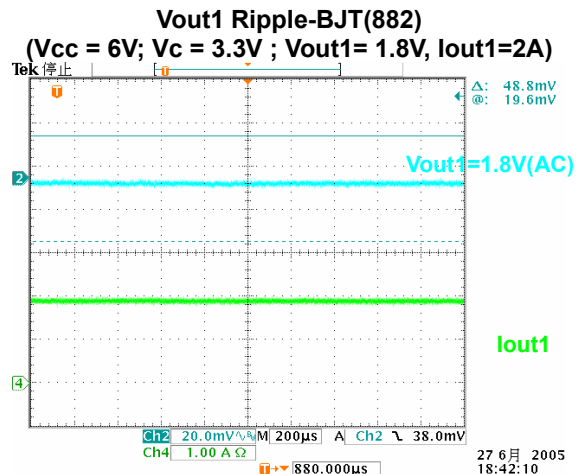
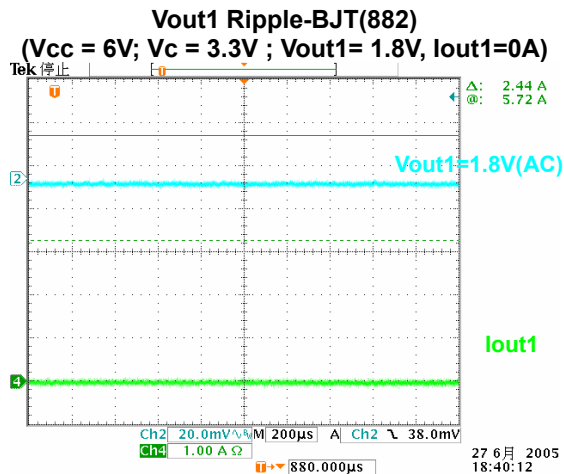

Not Recommended for New Design



AP451

2 Channel Linear Controller with Independent Enable Function

■ Marking Information

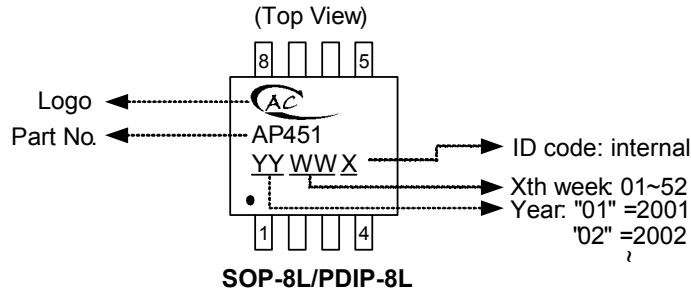

■ Package Information

(1) SOP-8L

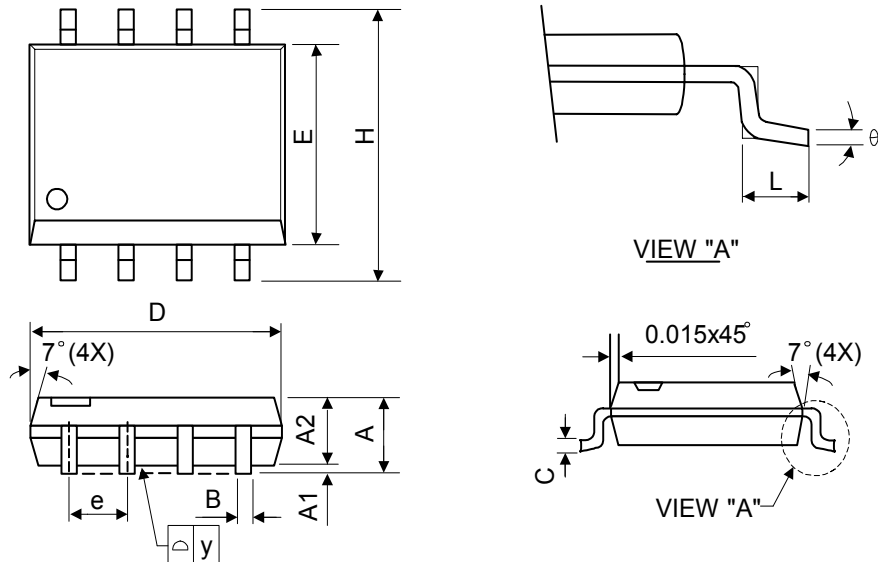

Symbol	Dimensions In Millimeters			Dimensions In Inches		
	Min.	Nom.	Max.	Min.	Nom.	Max.
A	1.40	1.60	1.75	0.055	0.063	0.069
A1	0.10	-	0.25	0.040	-	0.100
A2	1.30	1.45	1.50	0.051	0.057	0.059
B	0.33	0.41	0.51	0.013	0.016	0.020
C	0.19	0.20	0.25	0.0075	0.008	0.010
D	4.80	5.05	5.30	0.189	0.199	0.209
E	3.70	3.90	4.10	0.146	0.154	0.161
e	-	1.27	-	-	0.050	-
H	5.79	5.99	6.20	0.228	0.236	0.244
L	0.38	0.71	1.27	0.015	0.028	0.050
y	-	-	0.10	-	-	0.004
θ	0°	-	8°	0°	-	8°

Not Recommended for New Design



AP451

2 Channel Linear Controller with Independent Enable Function

Package Information (Continued)

(2) PDIP-8L

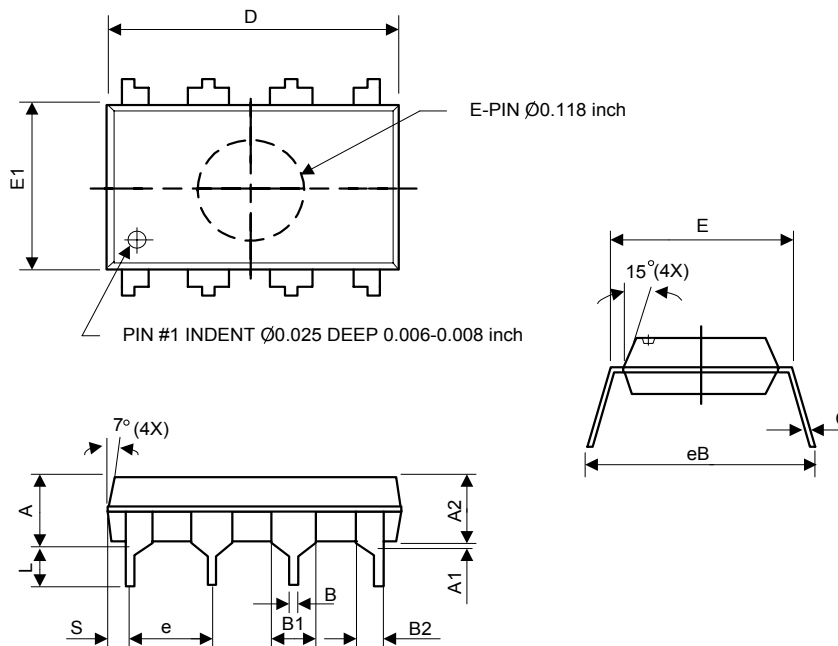

Symbol	Dimensions in millimeters			Dimensions in inches		
	Min.	Nom.	Max.	Min.	Nom.	Max.
A	-	-	5.33	-	-	0.210
A1	0.38	-	-	0.015	-	-
A2	3.1	3.30	3.5	0.122	0.130	0.138
B	0.36	0.46	0.56	0.014	0.018	0.022
B1	1.4	1.52	1.65	0.055	0.060	0.065
B2	0.81	0.99	1.14	0.032	0.039	0.045
C	0.20	0.25	0.36	0.008	0.010	0.014
D	9.02	9.27	9.53	0.355	0.365	0.375
E	7.62	7.94	8.26	0.300	0.313	0.325
E1	6.15	6.35	6.55	0.242	0.250	0.258
e	-	2.54	-	-	0.100	-
L	2.92	3.3	3.81	0.115	0.130	0.150
eB	8.38	8.89	9.70	0.330	0.350	0.382
S	0.71	0.84	0.97	0.028	0.033	0.038