

PRODUCT DATA DRAWING

REVISION HISTORY			
REV	DESCRIPTION	DATE	APPROVED
-	REL. DCN 40145	10/24/13	STW
A	DCN 48141	11/18	STW

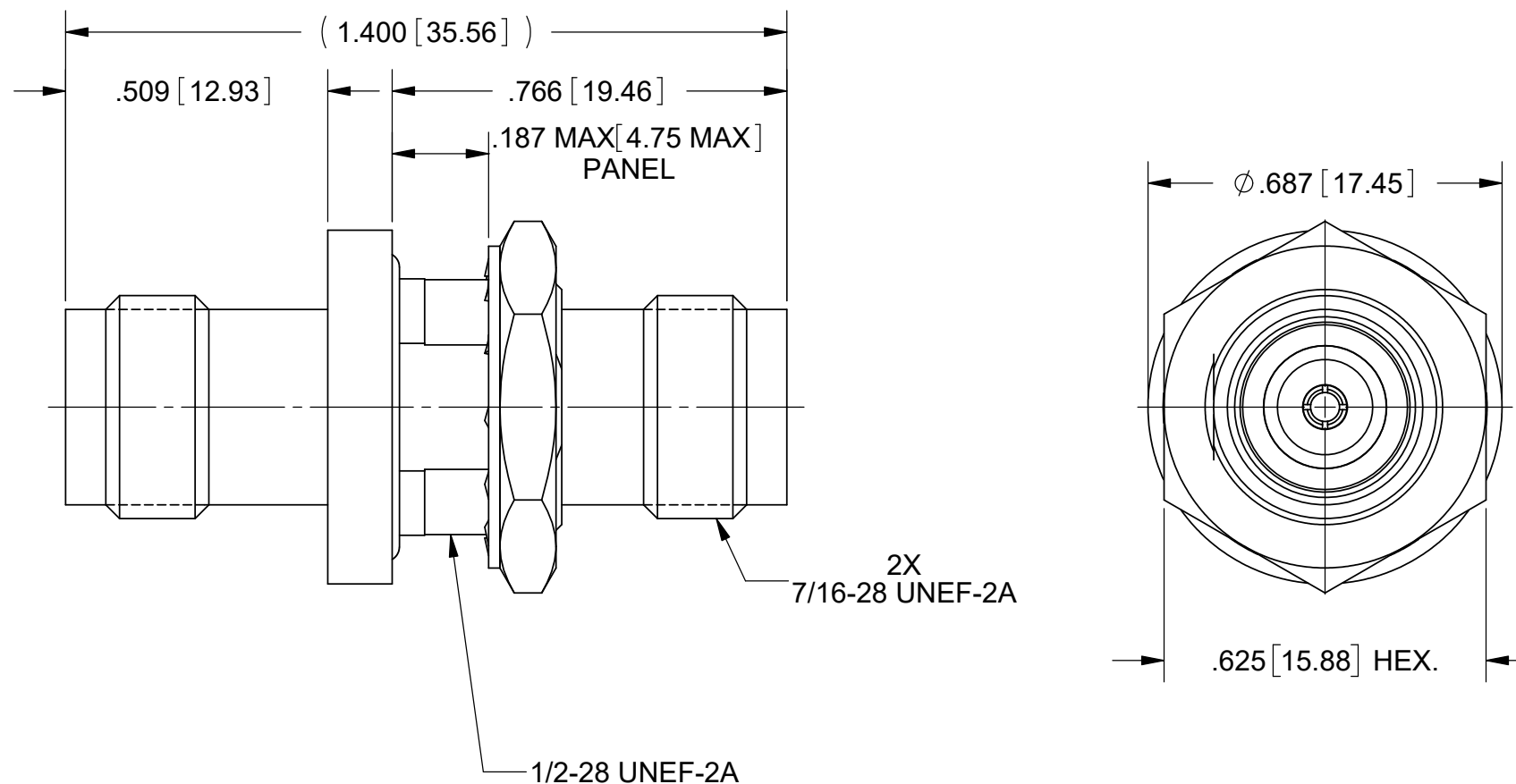

MATERIAL:

BODY, & HEX.NUT: STAINLESS STEEL PER AMS 5640, UNS ALLOY S30300 OR ASTM A582, TYPE 303.

CONTACT: BERYLLIUM COPPER PER ASTM B196, ALLOY No. UNS C17300, TD04

INSULATORS: PTFE PER ASTM D1710, TYPE I, GRADE 1, CLASS B

LOCK WASHER: 300 SERIES STAINLESS STEEL.

O-RING: RUBBER (VITON) PER AMS 7276, TYPE 1, CLASS 1

FINISH:

BODY, HEX NUT, & LOCK WASHER: PASSIVATED PER AMS 2700

CONTACT: GOLD PER ASTM B488, TYPE II, CODE C, CLASS 1.27, OVER NICKEL PER AMS-QQ-N-290, CLASS 1, .000050 MIN.

PERFORMANCE:

IMPEDANCE: 50 OHMS
FREQ. RANGE: DC TO 18.0 GHz
OPERATING TEMP.: -65 °C TO +165 °C

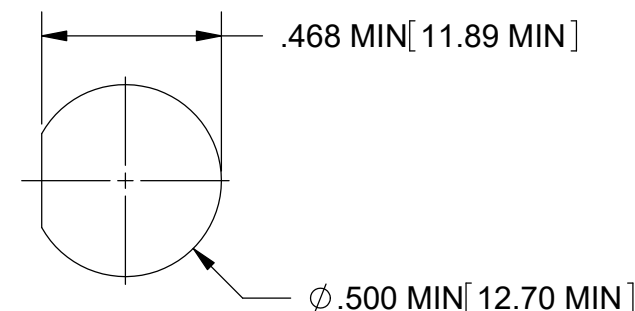

RECOMMENDED MOUNTING HOLE
SCALE 2:1

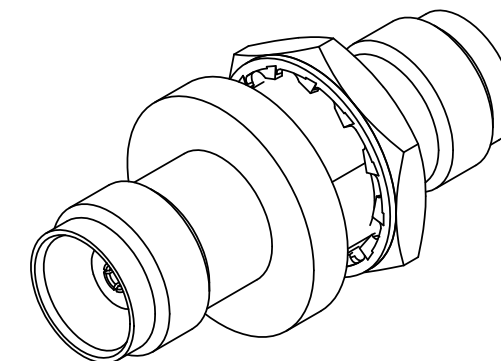

MATERIAL: SEE NOTES	DIMENSIONS ARE IN INCHES TOLERANCES: FRACTIONAL: ±1/64 ANGULAR: X° ±1'0" X"X' ±15'	UNLESS OTHERWISE SPECIFIED 1) ALL DIMENSIONS ARE IN INCHES (MILLIMETERS) 2) ALL DIMENSIONS ARE AFTER PLATING. 3) BREAK CORNERS & EDGES .005 R. MAX. 4) CHAM. 1ST & LAST THREADS. 5) SURFACE ROUGHNESS 63-MIL-STD-10. 6) DIA.'S ON COMMON CENTERS TO BE CONCENTRIC WITHIN .005 T.I.R. 7) REMOVE ALL BURRS	SV Microwave, Inc. 2400 Centrepark West Drive, Suite 100 West Palm Beach, FL 33409
FINISH: SEE NOTES	DECIMAL: X ±.030 .XX ±.010 .XXX ±.005	INTERPRET DIMENSIONS AND TOLERANCES PER ASME Y14.5M - 1994	TITLE: TNC JACK TO JACK BULKHEAD ADAPTER
SURFACE AREA: N/A	THIRD ANGLE PROJECTION	DRAWN: JMC 10/24/13 CHECKED: STW 10/24/13 APPROVED: STW 10/24/13	SIZE: B CAGE CODE: 95077 DWG. NO.: SF4532-6009
<p>PROPRIETARY</p> <p>THE INFORMATION CONTAINED IN THIS DRAWING IS THE SOLE PROPERTY OF SV MICROWAVE, INC. ANY REPRODUCTION IN PART OR AS A WHOLE WITHOUT THE WRITTEN PERMISSION OF SV MICROWAVE, INC IS PROHIBITED.</p>			SCALE: 3:1 SHEET 1 OF 1