

GENERAL DESCRIPTION

The 86004-01 is a high performance 1-to-4 LVCMOS/LVTTTL Clock Buffer and a member of the family of High Performance Clock Solutions from IDT. The 86004-01 has a fully integrated PLL and can be configured as zero delay buffer and has an input and output frequency range of 62.5MHz to 250MHz. The external feedback allows the device to achieve “zero delay” between the input clock and the output clocks. The PLL_SEL pin can be used to bypass the PLL for system test and debug purposes. In bypass mode, the reference clock is routed around the PLL and into the internal output divider.

CONTROL INPUT FUNCTION TABLE

Input	Input/Output Frequency Range (MHz)	
	Minimum	Maximum
F_SEL = 0	125	250
F_SEL = 1	62.5	125

BLOCK DIAGRAM

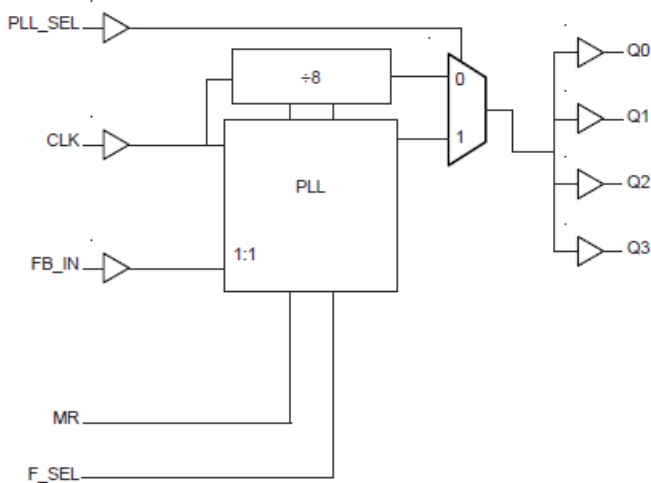

FEATURES

- Four LVCMOS/LVTTTL outputs, 7Ω typical output impedance
- Single LVCMOS/LVTTTL clock input
- CLK accepts the following input levels: LVCMOS or LVTTTL
- Output frequency range: 62.5MHz to 250MHz
- Input frequency range: 62.5MHz to 250MHz
- External feedback for “zero delay” clock regeneration with configurable frequencies
- Fully integrated PLL
- Cycle-to-cycle jitter, (F_SEL = 1): 45ps (maximum)
- Output skew: 60ps (maximum)
- Supply Voltage Modes: (Core/Output)
3.3V/3.3V
3.3V/2.5V
2.5V/2.5V
- 5V tolerant input
- -40°C to 70°C ambient operating temperature
- Available in lead-free (RoHS 6) package

PIN ASSIGNMENT

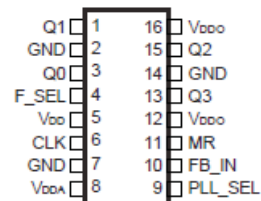

86004-01

16-Lead TSSOP

4.4mm x 5.0mm x 0.925mm package body

G Package

Top View

TABLE 1. PIN DESCRIPTIONS

Number	Name	Type		Description
1, 3, 13, 15	Q1, Q0, Q3, Q2	Output		Clock outputs. 7Ω typical output impedance. LVCMOS/LVTTL interface levels.
2, 7, 14	GND	Power		Power supply ground.
4	F_SEL	Input	Pulldown	Frequency range select input. When LOW, I/O frequency range is from 125MHz to 250Mz. When HIGH, I/O frequency range is from 62.5MHz to 125MHz. LVCMOS/LVTTL interface levels.
5	V _{DD}	Power		Core supply pin.
6	CLK	Input	Pulldown	LVCMOS/LVTTL clock input.
8	V _{DDA}	Power		Analog supply pin.
9	PLL_SEL	Input	Pullup	Selects between the PLL and reference clock as input to the dividers. When LOW, selects the reference clock (PLL Bypass). When HIGH, selects PLL (PLL Enabled). LVCMOS/LVTTL interface levels.
10	FB_IN	Input	Pulldown	Feedback input to phase detector for regenerating clocks with “zero delay”. Connect to one of the outputs. LVCMOS/LVTTL interface levels.
11	MR	Input	Pulldown	Active HIGH Master Reset. When logic HIGH, the internal dividers are reset causing the outputs to go low. When logic LOW, the internal dividers and the outputs are enabled. LVCMOS/LVTTL interface levels.
12, 16	V _{DDO}	Power		Output supply pins.

NOTE: *Pullup* and *Pulldown* refer to internal input resistors. See Table 2, Pin Characteristics, for typical values.

TABLE 2. PIN CHARACTERISTICS

Symbol	Parameter	Test Conditions	Minimum	Typical	Maximum	Units
C _{IN}	Input Capacitance			4		pF
R _{PULLUP}	Input Pullup Resistor			51		kΩ
R _{PULLDOWN}	Input Pulldown Resistor			51		kΩ
C _{PD}	Power Dissipation Capacitance (per output)	V _{DD} , V _{DDO} = 3.465V			23	pF
		V _{DD} , V _{DDO} = 2.625V			17	pF
R _{OUT}	Output Impedance	3.3V ± 5%	5	7	12	Ω

TABLE 3. CONTROL INPUT FUNCTION TABLE

Input	Input/Output Frequency Range (MHz)	
	Minimum	Maximum
F_SEL = 0	125	250
F_SEL = 1	62.5	125

ABSOLUTE MAXIMUM RATINGS

Supply Voltage, V_{DD}	4.6V
Inputs, V_I	-0.5V to +5.0V
Outputs, V_O	-0.5V to $V_{DDO} + 0.5V$
Package Thermal Impedance, θ_{JA}	89°C/W (0 lfpm)
Storage Temperature, T_{STG}	-65°C to 150°C

NOTE: Stresses beyond those listed under Absolute Maximum Ratings may cause permanent damage to the device. These ratings are stress specifications only. Functional operation of product at these conditions or any conditions beyond those listed in the *DC Characteristics* or *AC Characteristics* is not implied. Exposure to absolute maximum rating conditions for extended periods may affect product reliability.

TABLE 4A. POWER SUPPLY DC CHARACTERISTICS, $V_{DD} = V_{DDO} = 3.3V \pm 5\%$, $T_A = -40^\circ\text{C}$ TO 70°C

Symbol	Parameter	Test Conditions	Minimum	Typical	Maximum	Units
V_{DD}	Core Supply Voltage		3.135	3.3	3.465	V
V_{DDA}	Analog Supply Voltage		3.135	3.3	V_{DD}	V
V_{DDO}	Output Supply Voltage		3.135	3.3	3.465	V
I_{DD}	Power Supply Current				100	mA
I_{DDA}	Analog Supply Current				16	mA
I_{DDO}	Output Supply Current				6	mA

NOTE: Special thermal handling may be required in some configurations.

TABLE 4B. POWER SUPPLY DC CHARACTERISTICS, $V_{DD} = 3.3V \pm 5\%$, $V_{DDO} = 2.5V \pm 5\%$, $T_A = -40^\circ\text{C}$ TO 70°C

Symbol	Parameter	Test Conditions	Minimum	Typical	Maximum	Units
V_{DD}	Core Supply Voltage		3.135	3.3	3.465	V
V_{DDA}	Analog Supply Voltage		3.135	3.3	V_{DD}	V
V_{DDO}	Output Supply Voltage		2.375	2.5	2.625	V
I_{DD}	Power Supply Current				100	mA
I_{DDA}	Analog Supply Current				16	mA
I_{DDO}	Output Supply Current				6	mA

TABLE 4C. POWER SUPPLY DC CHARACTERISTICS, $V_{DD} = V_{DDO} = 2.5V \pm 5\%$, $T_A = -40^\circ\text{C}$ TO 70°C

Symbol	Parameter	Test Conditions	Minimum	Typical	Maximum	Units
V_{DD}	Core Supply Voltage		2.375	2.5	2.625	V
V_{DDA}	Analog Supply Voltage		2.375	2.5	V_{DD}	V
V_{DDO}	Output Supply Voltage		2.375	2.5	2.625	V
I_{DD}	Power Supply Current				96	mA
I_{DDA}	Analog Supply Current				15	mA
I_{DDO}	Output Supply Current				6	mA

NOTE: Special thermal handling may be required in some configurations.

TABLE 4D. LVCMOS / LVTTTL DC CHARACTERISTICS, $V_{DD} = V_{DDO} = 3.3V \pm 5\%$ OR $2.5V \pm 5\%$, $T_A = -40^\circ\text{C}$ TO 70°C

Symbol	Parameter	Test Conditions	Minimum	Typical	Maximum	Units
V_{IH}	Input High Voltage	$V_{DD} = 3.465V$	2.0		5.0	V
		$V_{DD} = 2.625V$	1.7		5.0	V
V_{IL}	Input Low Voltage	$V_{DD} = 3.465V$	-0.3		0.8	V
		$V_{DD} = 2.625V$	-0.3		0.7	V
I_{IH}	Input High Current	CLK, MR, FB_IN, F_SEL $V_{DD} = V_{IN} = 3.465V$ or $2.625V$			150	μA
		PLL_SEL $V_{DD} = V_{IN} = 3.465V$ or $2.625V$			5	μA
I_{IL}	Input Low Current	CLK, MR, FB_IN, F_SEL $V_{DD} = 3.465V$ or $2.625V$, $V_{IN} = 0V$	-5			μA
		PLL_SEL $V_{DD} = 3.465V$ or $2.625V$, $V_{IN} = 0V$	-150			μA
V_{OH}	Output High Voltage; NOTE 1	$V_{DDO} = 3.465V$	2.6			V
		$V_{DDO} = 2.625V$	1.8			V
V_{OL}	Output Low Voltage; NOTE 1	$V_{DDO} = 3.465V$ or $2.625V$			0.5	V

NOTE 1: Outputs terminated with 50Ω to $V_{DDO}/2$. See Parameter Measurement Information Section, *Output Load Test Circuit diagrams*.

TABLE 5A. AC CHARACTERISTICS, $V_{DD} = V_{DDO} = 3.3V \pm 5\%$, $T_A = -40^\circ\text{C}$ TO 70°C

Symbol	Parameter	Test Conditions	Minimum	Typical	Maximum	Units
f_{MAX}	Output Frequency	F_SEL = 0	125		250	MHz
		F_SEL = 1	62.5		125	MHz
t_{pLH}	Propagation Delay, Low-to-High; NOTE 1	PLL_SEL = 0V, Bypass Mode	4.1	5.1	6.1	ns
$t(\emptyset)$	Static Phase Offset; NOTE 2, 4	PLL_SEL = 3.3V	-75	50	175	ps
$t_{sk(o)}$	Output Skew; NOTE 3, 4	PLL_SEL = 0V			60	ps
$t_{jit(cc)}$	Cycle-to-Cycle Jitter; NOTE 4	F_SEL = 0			65	ps
		F_SEL = 1			45	ps
t_L	PLL Lock Time				1	mS
t_R / t_F	Output Rise/Fall Time		300		750	ps
odc	Output Duty Cycle	F_SEL = 0	44	50	56	%
		F_SEL = 1	47	50	53	%

NOTE: Electrical parameters are guaranteed over the specified ambient operating temperature range, which is established when the device is mounted in a test socket with maintained transverse airflow greater than 500 lfm. The device will meet specifications after thermal equilibrium has been reached under these conditions. All parameters measured at f_{MAX} unless noted otherwise.

All parameters measured at f_{MAX} unless noted otherwise.

NOTE 1: Measured from the differential input crossing point to the output at $V_{DDO}/2$.

NOTE 2: Defined as the time difference between the input reference clock and the average feedback input signal when the PLL is locked and the input reference frequency is stable.

NOTE 3: Defined as skew between outputs at the same supply voltages and with equal load conditions.

Measured at $V_{DDO}/2$.

NOTE 4: This parameter is defined in accordance with JEDEC Standard 65.

TABLE 5B. AC CHARACTERISTICS, $V_{DD} = 3.3V \pm 5\%$, $V_{DDO} = 2.5V \pm 5\%$, $T_A = -40^\circ\text{C}$ TO 70°C

Symbol	Parameter	Test Conditions	Minimum	Typical	Maximum	Units
f_{MAX}	Output Frequency	F_SEL = 0	125		250	MHz
		F_SEL = 1	62.5		125	MHz
$t_{p_{LH}}$	Propagation Delay, Low-to-High; NOTE 1	PLL_SEL = 0V, Bypass Mode	4.25	5.25	6.25	ns
$t(\emptyset)$	Static Phase Offset; NOTE 2, 4	PLL_SEL = 3.3V	-300		0	ps
$t_{sk(o)}$	Output Skew; NOTE 3, 4	PLL_SEL = 0V			60	ps
$f_{jit(cc)}$	Cycle-to-Cycle Jitter; NOTE 4	F_SEL = 0			65	ps
		F_SEL = 1			45	ps
t_L	PLL Lock Time				1	mS
t_R / t_F	Output Rise/Fall Time		300		700	ps
odc	Output Duty Cycle		45	50	55	%

NOTE: Electrical parameters are guaranteed over the specified ambient operating temperature range, which is established when the device is mounted in a test socket with maintained transverse airflow greater than 500 lfm. The device will meet specifications after thermal equilibrium has been reached under these conditions. All parameters measured at f_{MAX} unless noted otherwise.

All parameters measured at f_{MAX} unless noted otherwise.

NOTE 1: Measured from the differential input crossing point to the output at $V_{DDO}/2$.

NOTE 2: Defined as the time difference between the input reference clock and the average feedback input signal when the PLL is locked and the input reference frequency is stable.

NOTE 3: Defined as skew between outputs at the same supply voltages and with equal load conditions.

Measured at $V_{DDO}/2$.

NOTE 4: This parameter is defined in accordance with JEDEC Standard 65.

TABLE 5C. AC CHARACTERISTICS, $V_{DD} = V_{DDO} = 2.5V \pm 5\%$, $T_A = -40^\circ\text{C}$ TO 70°C

Symbol	Parameter	Test Conditions	Minimum	Typical	Maximum	Units
f_{MAX}	Output Frequency	F_SEL = 0	125		250	MHz
		F_SEL = 1	62.5		125	MHz
$t_{p_{LH}}$	Propagation Delay, Low-to-High; NOTE 1	PLL_SEL = 0V, Bypass Mode	4.5	5.5	6.5	ns
$t(\emptyset)$	Static Phase Offset; NOTE 2, 4	PLL_SEL = 3.3V	-100		250	ps
$t_{sk(o)}$	Output Skew; NOTE 3, 4	PLL_SEL = 0V			55	ps
$f_{jit(cc)}$	Cycle-to-Cycle Jitter; NOTE 4	F_SEL = 0			65	ps
		F_SEL = 1			45	ps
t_L	PLL Lock Time				1	mS
t_R / t_F	Output Rise/Fall Time		300		700	ps
odc	Output Duty Cycle		45	50	55	%

NOTE: Electrical parameters are guaranteed over the specified ambient operating temperature range, which is established when the device is mounted in a test socket with maintained transverse airflow greater than 500 lfm. The device will meet specifications after thermal equilibrium has been reached under these conditions. All parameters measured at f_{MAX} unless noted otherwise.

NOTE 1: Measured from the differential input crossing point to the output at $V_{DDO}/2$.

NOTE 2: Defined as the time difference between the input reference clock and the average feedback input signal when the PLL is locked and the input reference frequency is stable.

NOTE 3: Defined as skew between outputs at the same supply voltages and with equal load conditions.

Measured at $V_{DDO}/2$.

NOTE 4: This parameter is defined in accordance with JEDEC Standard 65.

PARAMETER MEASUREMENT INFORMATION

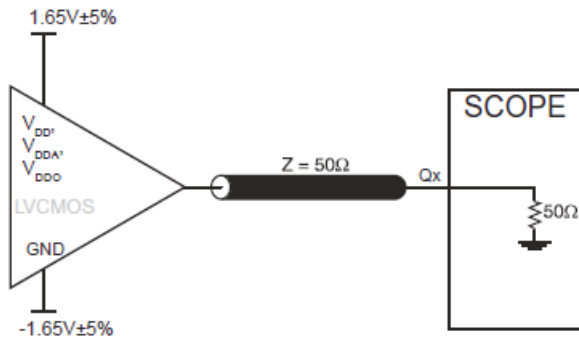
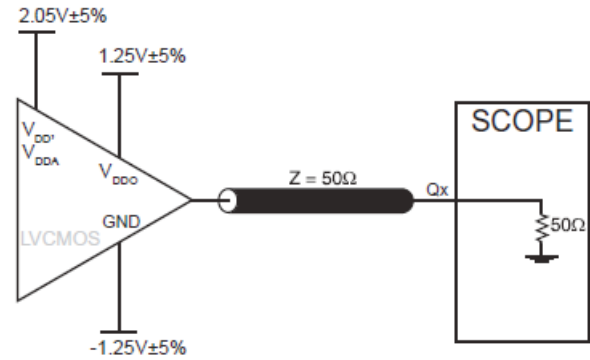
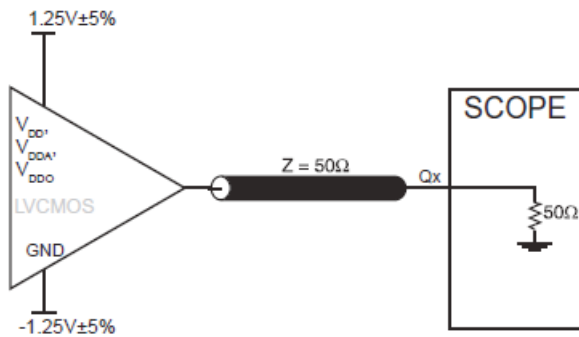
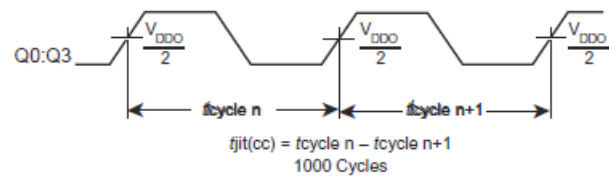
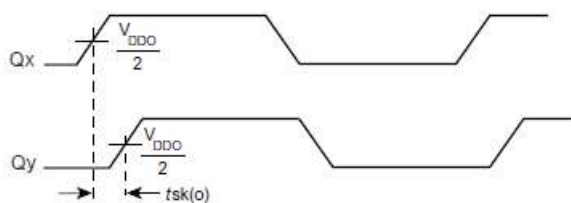
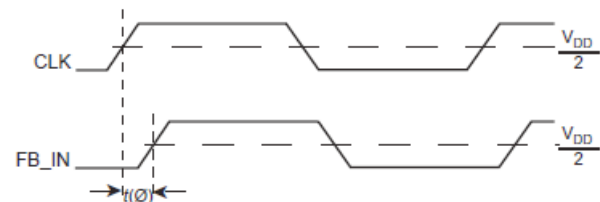
3.3V CORE/3.3V OUTPUT LOAD AC TEST CIRCUIT

3.3V CORE/2.5V OUTPUT LOAD AC TEST CIRCUIT

2.5V CORE/ 2.5V OUTPUT LOAD AC TEST CIRCUIT

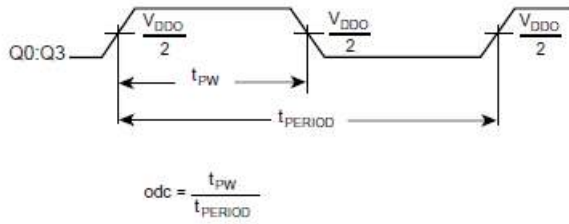
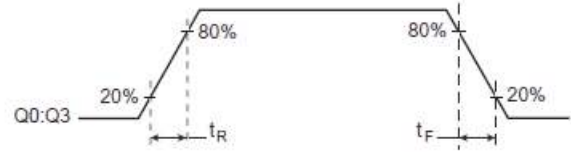
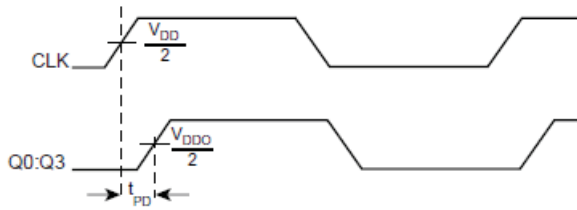
CYCLE-TO-CYCLE JITTER

OUTPUT SKEW

$t(\varnothing)_{mean}$ = Static Phase Offset
 (where $t(\varnothing)$ is any random sample, and $t(\varnothing)_{mean}$ is the average of the sampled cycles measured on controlled edges)

STATIC PHASE OFFSET

OUTPUT DUTY CYCLE/PULSE WIDTH/PERIOD

OUTPUT RISE/FALL TIME

PROPAGATION DELAY

APPLICATION INFORMATION

POWER SUPPLY FILTERING TECHNIQUES

As in any high speed analog circuitry, the power supply pins are vulnerable to random noise. To achieve optimum jitter performance, power supply isolation is required. The 86004-01 provides separate power supplies to isolate any high switching noise from the outputs to the internal PLL. V_{DD} , V_{DDA} and V_{DDO} should be individually connected to the power supply plane through vias, and $0.01\mu\text{F}$ bypass capacitors should be used for each pin. *Figure 1* illustrates this for a generic V_{DD} pin and also shows that V_{DDA} requires that an additional 10Ω resistor along with a $10\mu\text{F}$ bypass capacitor be connected to the V_{DDA} pin.

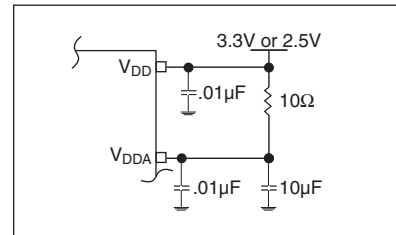

FIGURE 1. POWER SUPPLY FILTERING

RECOMMENDATIONS FOR UNUSED INPUT AND OUTPUT PINS

INPUTS:

LVC MOS CONTROL PINS:

All control pins have internal pullups or pulldowns; additional resistance is not required but can be added for additional protection. A $1\text{k}\Omega$ resistor can be used.

OUTPUTS:

LVC MOS OUTPUTS:

All unused LVC MOS output can be left floating. We recommend that there is no trace attached.

SCHEMATIC EXAMPLE

Figure 2 shows a schematic example of using an 86004-01. It is recommended to have one decouple capacitor per power pin. Each decoupling capacitor should be located as close as

possible to the power pin. The low pass filter R7, C11 and C16 for clean analog supply should also be located as close to the V_{DDA} pin as possible.

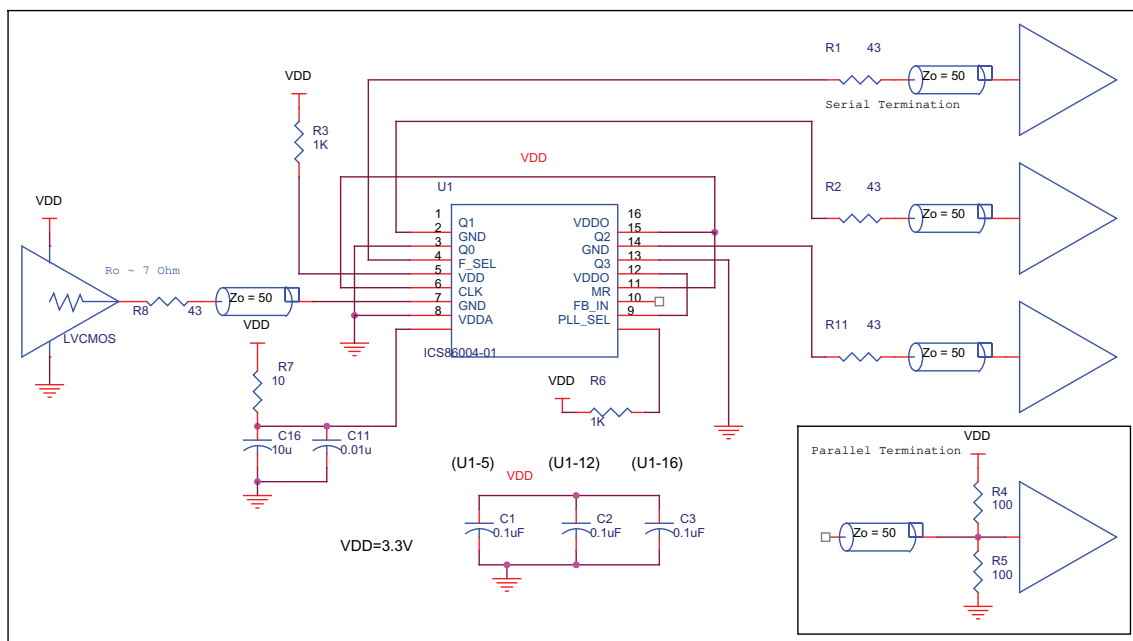

FIGURE 2. 86004-01 SCHEMATIC EXAMPLE

RELIABILITY INFORMATION

TABLE 6. θ_{JA} VS. AIR FLOW TABLE FOR 16 LEAD TSSOP

θ_{JA} by Velocity (Linear Feet per Minute)			
	0	200	500
Single-Layer PCB, JEDEC Standard Test Boards	137.1°C/W	118.2°C/W	106.8°C/W
Multi-Layer PCB, JEDEC Standard Test Boards	89.0°C/W	81.8°C/W	78.1°C/W

NOTE: Most modern PCB designs use multi-layered boards. The data in the second row pertains to most designs.

TRANSISTOR COUNT

The transistor count for 86004-01 is: 2496

PACKAGE OUTLINE AND DIMENSIONS

PACKAGE OUTLINE - G SUFFIX 16 LEAD TSSOP

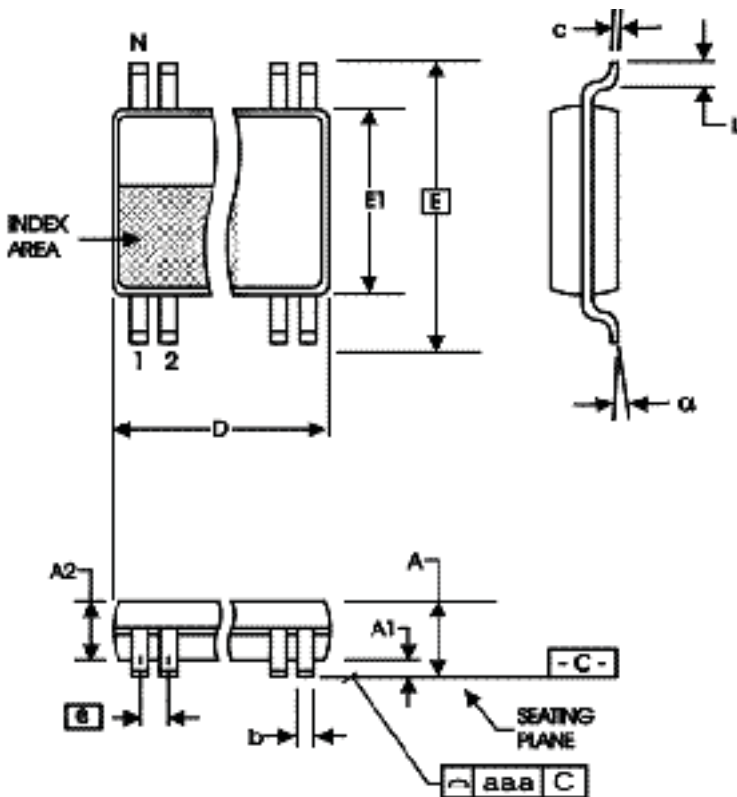

TABLE 7. PACKAGE DIMENSIONS

SYMBOL	Millimeters	
	Minimum	Maximum
N	16	
A	--	1.20
A1	0.05	0.15
A2	0.80	1.05
b	0.19	0.30
c	0.09	0.20
D	4.90	5.10
E	6.40 BASIC	
E1	4.30	4.50
e	0.65 BASIC	
L	0.45	0.75
α	0°	8°
aaa	--	0.10

Reference Document: JEDEC Publication 95, MO-153

TABLE 8. ORDERING INFORMATION

Part/Order Number	Marking	Package	Shipping Packaging	Temperature
86004BG-01LF	6004B01L	16 lead "Lead Free" TSSOP	Tube	0°C to +70°C
86004BG-01LFT	6004B01L	16 lead "Lead Free" TSSOP	Tape and Reel	0°C to +70°C

REVISION HISTORY SHEET				
Rev	Table	Page	Description of Change	Date
A			Throughout data sheet, changed part number from ICS86004I-01 to ICS86004-01.	12/16/03
A	T7	1 11	Features section - added Lead-Free bullet. Ordering Information table - added Lead Free part number.	9/7/04
A			Changed temperature range throughout the data sheet from “-40°C - 85°C” to “0°C - 70°C”.	11/2/04
B	T4A T4B T4C T7	1 3 3 3 11	Features section - changed Ambient Operating Temperature from 0°C to -40°C and throughout the datasheet. 3.3V Power Supply Table - changed V_{DDA} max. from 3.465V to V_{DD} . Added note. 3.3V/2.5V Power Supply Table - changed V_{DDA} max. from 3.465V to V_{DD} . Added note. 2.5V Power Supply Table - changed V_{DDA} max. from 3.465V to V_{DD} . Added note. Ordering Information Table - added lead-free note.	06/21/06
C	T4D	4	LVC MOS DC Characteristics Table - defined 2.5V V_{IH} , V_{IL} specs.	11/30/06
D	T4B T4D T5A - T5C	3 3 4 5 - 6	Absolute Maximum Ratings - Inputs, V_i changed from -0.5V to $V_{DD} + 0.5V$ to -0.5V to 5.0V. Mix Power Supply Table - corrected V_{DD} and V_{DDA} from 2.5V± to 3.3V±. LVC MOS DC Characteristics Table - V_{IH} rows - changed max. from $V_{DD} + 0.3V$ to 5.0V. AC Tables - added ambient temperature note.	1/19/09
D	T8	1 1 10	Removed ICS from the part number where needed. General Description - Deleted ICS Chip and HiPerClockS. Features Section - removed reference to leaded package. Ordering Information - removed quantity for tape and reel. Deleted LF note below the table. Updated header and footer.	1/21/16

**Corporate Headquarters**6024 Silver Creek Valley Road
San Jose, CA 95138 USAwww.IDT.com**Sales**1-800-345-7015 or 408-284-8200
Fax: 408-284-2775www.IDT.com/go/sales**Tech Support**www.idt.com/go/support

DISCLAIMER Integrated Device Technology, Inc. (IDT) reserves the right to modify the products and/or specifications described herein at any time, without notice, at IDT's sole discretion. Performance specifications and operating parameters of the described products are determined in an independent state and are not guaranteed to perform the same way when installed in customer products. The information contained herein is provided without representation or warranty of any kind, whether express or implied, including, but not limited to, the suitability of IDT's products for any particular purpose, an implied warranty of merchantability, or non-infringement of the intellectual property rights of others. This document is presented only as a guide and does not convey any license under intellectual property rights of IDT or any third parties.

IDT's products are not intended for use in applications involving extreme environmental conditions or in life support systems or similar devices where the failure or malfunction of an IDT product can be reasonably expected to significantly affect the health or safety of users. Anyone using an IDT product in such a manner does so at their own risk, absent an express, written agreement by IDT.

Integrated Device Technology, IDT and the IDT logo are trademarks or registered trademarks of IDT and its subsidiaries in the United States and other countries. Other trademarks used herein are the property of IDT or their respective third party owners.

For datasheet type definitions and a glossary of common terms, visit www.idt.com/go/glossary.

Copyright ©2016 Integrated Device Technology, Inc. All rights reserved.