

# SPECIFICATIONS

PARAMETERS	VALUES	UNITS
RESONANT FREQUENCY	2,700 ± 500	Hz
RESONANT IMPEDANCE (MAX)	500	Ohm
MAX INPUT VOLTAGE	30	Vp-p
CAPACITANCE @ 120 HZ	40,000 ± 30%	pF
PLATE MATERIAL	BRASS	-
OPERATING TEMPERATURE	-20 ~ +60	°C
STORAGE TEMPERATURE	-20 ~ +70	°C

THIS DOCUMENT CONTAINS DATA PROPRIETARY TO PROJECTS UNLIMITED, INC. ANY USE OR REPRODUCTION, IN ANY FORM, WITHOUT PRIOR WRITTEN PERMISSION OF PROJECTS UNLIMITED, INC. IS PROHIBITED.  
©2003, Projects Unlimited Inc.

# REVISION HISTORY

LTR	DESCRIPTION	DATE	APPROVED
-	RELEASED FROM ENGINEERING	11/20/2013	
A	REVISED CAPACITANCE FREQUENCY	2/14/2020	M.V.

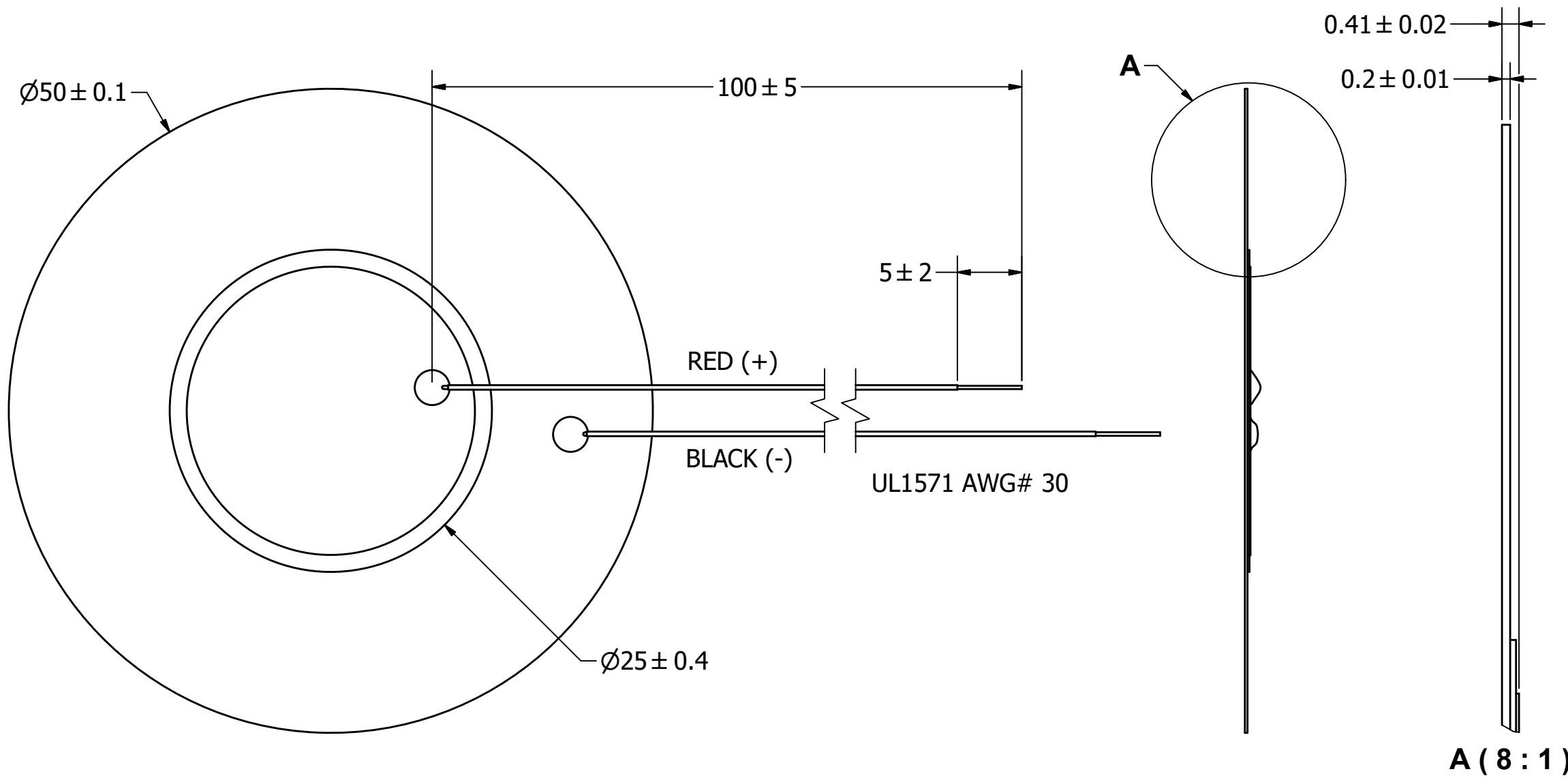

A (8:1)

## NOTES:

1. ALL DIMENSIONS ARE IN MILLIMETERS.
2. SPECIFICATIONS SUBJECT TO CHANGE OR WITHDRAWL WITHOUT NOTICE.
3. THIS PART IS RoHS 2011/65/EU COMPLIANT.

UNLESS OTHERWISE SPECIFIED: DIMENSIONS ARE IN MILLIMETERS, TOLERANCES ARE $\pm 0.5$ AND ANGLES ARE $\pm 3^\circ$ .	SIZE <b>A3</b>	Designed by	Date	Checked by	Date	Approved by	Date	Drawn Date	
		J.D.	11/20/2013	X.X.	11/20/2013	X.X.	11/20/2013	11/20/2013	
AB5027B-3-LW100-R.idw				<b>AB5027B-3-LW100-R</b>					
Bender						Edition	Sheet		
						-	1 / 1		