

THIS DRAWING IS UNPUBLISHED. RELEASED FOR PUBLICATION
 © COPYRIGHT BY TYCO ELECTRONICS CORPORATION. ALL RIGHTS RESERVED.

LOC	DIST	REVISIONS					
DF	A0	P	LTR	DESCRIPTION	DATE	DWN	APVD
		C		REV PER ECO 06-00669	1-16-06	CT	DE

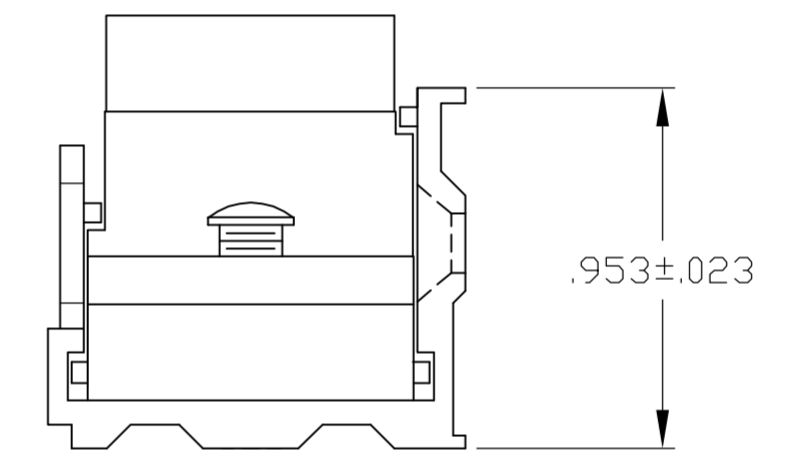
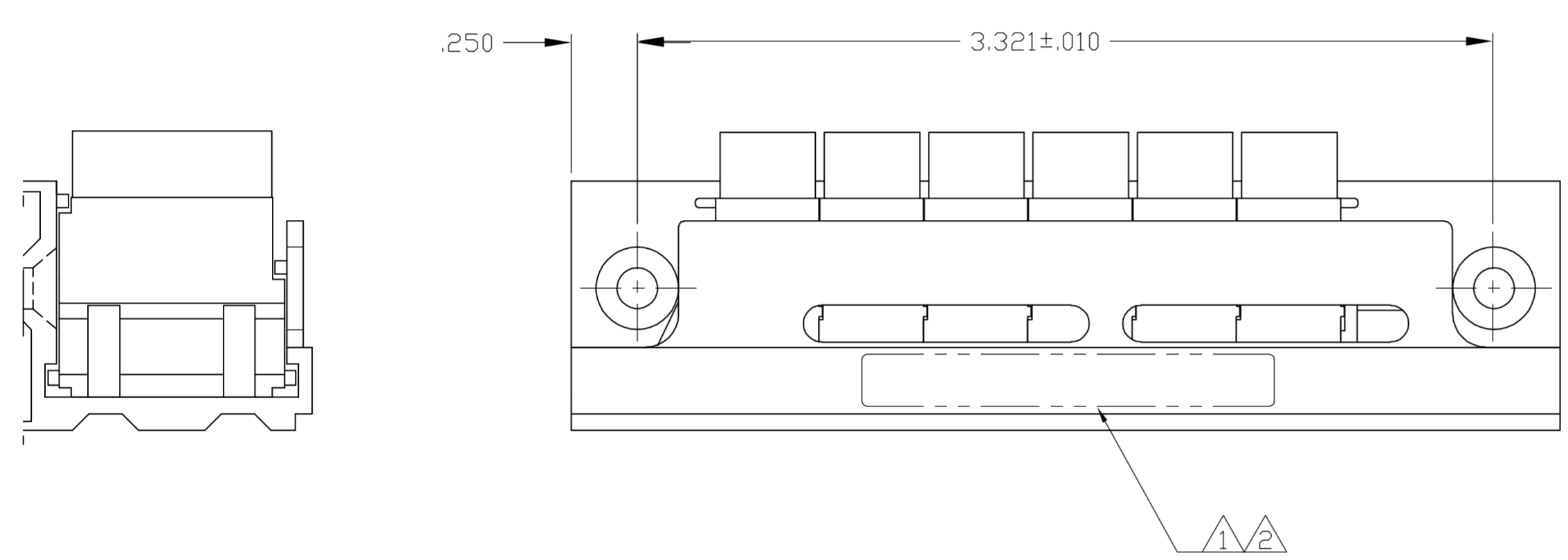
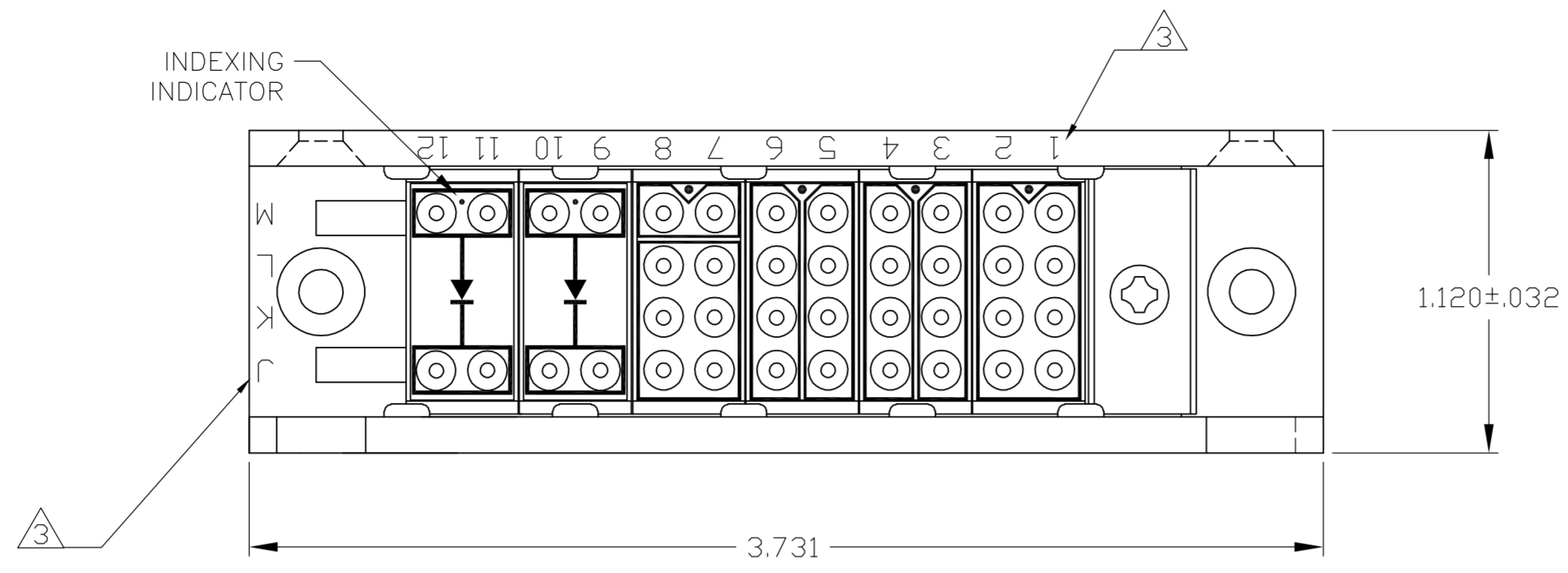

- 1 CUSTOMER PART NO. 12220BE-01A, MARKED IN AREA SHOWN.
- 2 RAIL MARKED WITH "AMP", AMP PART NUMBER AND DATE CODE IN AREA SHOWN.
- 3 TOP OF RAIL ASSEMBLY MARKED WITH ZONE IDENTIFICATION AS SHOWN.
- 4 ROLLS-ROYCE QUALITY SPECIFICATION CQC-103 IS INVOKED.

2 3	5-591629-1
SUPERSEDED BY -1	591629-2
1 2 3 4	591629-1
REMARKS	PART NO.

THIS DRAWING IS A CONTROLLED DOCUMENT.		DWN C.C.THOMAS 16JAN2006	Tyco Electronics Corporation Harrisburg, PA 17105-3608	
DIMENSIONS: INCHES		CHK D.EABY 1-16-06	NAME MODULE BLOCK/MOUNTING RAIL ASSY, SIZE 16,TJ	
TOLERANCES UNLESS OTHERWISE SPECIFIED:		APVD D.EABY 1-16-06	DRAWING NO A2 00779 C=591629	
0 PLC ± -		PRODUCT SPEC	RESTRICTED TO	
1 PLC ± -		APPLICATION SPEC	SCALE	SHEET
2 PLC ± -			2:1	1 of 1
3 PLC ± .015		WEIGHT	REV	C
4 PLC ± -				
ANGLES ± -		CUSTOMER DRAWING		
FINISH				