

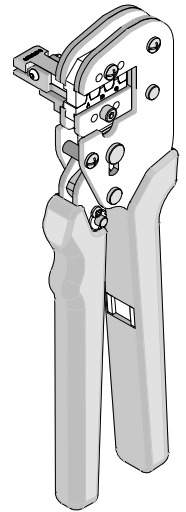

**ServiceGrade™ Hand Crimp Tool
Specification Sheet
Order No. 64016-0200**



FEATURES

- A full cycle ratcheting hand tool ensures complete crimps
- Ergonomic soft grip handles for comfortable crimping
- For crimps conforming to WHMA-IPCA620 Class 2, use hand crimp tools 63819-0900, and/or 63819-1000.

SCOPE

Products: Mini-Fit™ Jr. and Mini-Fit HCS™, Male and Female Crimp Terminals 16 - 28 AWG.

Terminal Series No.	Terminal Order No.			Wire Size		Insulation Diameter Maximum		Strip Length	
				AWG	mm ²	mm	In.	mm	In.
5556	39-00-0078	39-00-0158	39-00-0218	16	1.3	3.10	.122	3.00-3.50	.118-.138
	39-00-0080	39-00-0168	39-00-0448						
	39-00-0090	39-00-0180							
	39-00-0094	39-00-0186							
	39-00-0142	39-00-0212							
	39-00-0039	39-00-0164	39-00-0429	18-20 ▼	0.80-0.50				
	39-00-0056	39-00-0182	39-00-0441						
	39-00-0060	39-00-0195	40-13-0852						
	39-00-0074	39-00-0208							
	39-00-0154	39-00-0214							
	39-00-0047	39-00-0156		22-28	0.35-0.08	1.80	.071	2.79-3.30	.110-.130
	39-00-0066	39-00-0166							
	39-00-0086	39-00-0184							
	39-00-0092	39-00-0210							
39-00-0140	39-00-0435								
5558	39-00-0082	39-00-0125		16	1.3	3.10	.122	3.00-3.50	.118-.138
	39-00-0084	39-00-0131							
	39-00-0096	39-00-0224							
	39-00-0041	39-00-0076	39-00-0220	18-20 ▼	0.80-0.50				
	39-00-0054	39-00-0121	39-00-0431						
	39-00-0062	39-00-0127	40-13-0854						
	39-00-0049	39-00-0098	39-00-0216	22 - 28	0.35-0.08	1.80	.071	2.79-3.30	.110-.130
	39-00-0068	39-00-0123	39-00-0222						
39-00-0088	39-00-0129	39-00-0433							
30490	30490-1012	30490-2012		18-20 ▼	0.80-0.50	3.10	.122	3.00-3.50	.118-.138
44476	44476-3112			16	1.3	3.10	.122	3.00-3.50	.118-.138
	44476-1112	44476-1212		18-20	0.80-0.50				
44478	44478-3112			16	1.3	3.10	.122	3.00-3.50	.118-.138
	44478-1112			18-20	0.80-0.50				
44485	44485-3212	44485-3312	44485-3412	16	1.3	3.10	.122	3.00-3.50	.118-.138
	44485-1212	44485-1312	44485-1412	18-20 ▼	0.80-0.20				
45750	45750-3112	45750-3212		16	1.3	3.10	.122	3.00-3.50	.118-.138
	45750-1111	45750-1211		18-20	0.80-0.50				
46012	46012-3142	46012-3242		16	1.3	3.10	.122	3.00-3.50	.118-.138
	46012-1142	46012-1242		18-20	0.80-0.50				

Terminal Series No.	Terminal Order No.			Wire Size		Insulation Diameter Maximum		Strip Length	
				AWG	mm ²	mm	In.	mm	In.
46018	46018-3542			16	1.3	3.10	.122	3.00-3.50	.118-.138
	46018-1541			18-20	0.80-0.50				
46083	46083-3112	46083-3122	46083-3212	16	1.3	3.10	.122	3.00-3.50	.118-.138
	46083-1111	46083-3222							
	46083-1211			18-20	0.80-0.50				
	46083-1121	46083-1221							
46098	46098-3542			16	1.3	3.10	.122	3.00-3.50	.118-.138
	46098-1541			18-20	0.80-0.50				

▼ For the 22 and 24AWG terminals in this series use hand crimp tool 63819-0900

Crimping Information:

Crimp the terminal and appropriate gauge wire in the specified profile. Crimp profile “A” is for small-insulation terminals (do not crimp 22 or 24 AWG from an 18-24 AWG terminal in this profile).

Terminal Series No	Wire Size		Pull Force Min. ▼		Tool Crimp Profile		
	AWG	mm ²	N	Lb.	A	B	C
5556, 5558	16	1.30	68.5	15.40			X
	18	0.80	88.0	19.80		X	
	20	0.50	58.7	13.20		X	
	22	0.35	39.1	8.80	X		
	24	0.20	29.3	6.60	X		
	26	0.12	22.2	5.0	X		
	28	0.08	13.3	3.0	X		
30490	18	0.80	88.0	19.80		X	
	20	0.50	58.7	13.20		X	
44476, 44478, 45750	16	1.30	68.5	15.40			X
	18	0.80	88.0	19.80		X	
	20	0.50	58.7	13.20		X	
44485	16	1.30	68.5	15.40			X
	18	0.80	88.0	19.80		X	
	20	0.50	58.7	13.20		X	
46012, 46018, 46083, 46098	16	1.30	68.5	15.40			X
	18	0.80	68.5	15.40		X	
	20	0.50	58.7	13.20		X	

▼ Pull force test samples should not have the wire insulation crimped.

OPERATION

CAUTION: Install only Molex terminals listed above with this tool. Do not crimp hardened objects as damage can occur to the tool or die.

Remove the terminal holder from the tool and set it aside.

Open the hand tool by squeezing the handles together; at the end of the closing stroke the anti-backup ratchet will release. Release the handles and the hand tool will open.

Crimping Terminals

1. Select the desired terminal listed in the preceding charts.
2. Open the terminal holder by pressing down the lever and place the terminal in the holder.

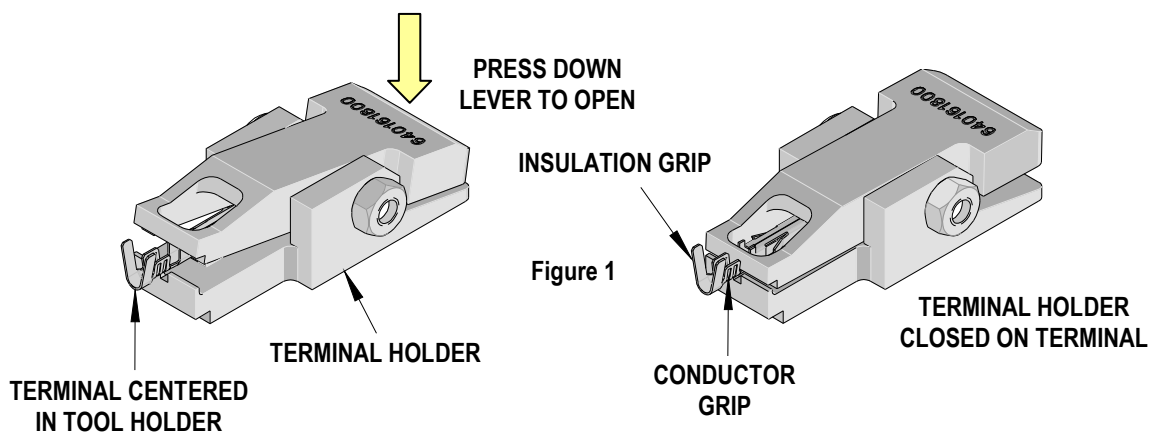

Note: The above illustration is a general representation. Some of the terminals may look different and be held in a different area of the terminal.

3. Release the lever to hold the terminal in place. See Figure 1.

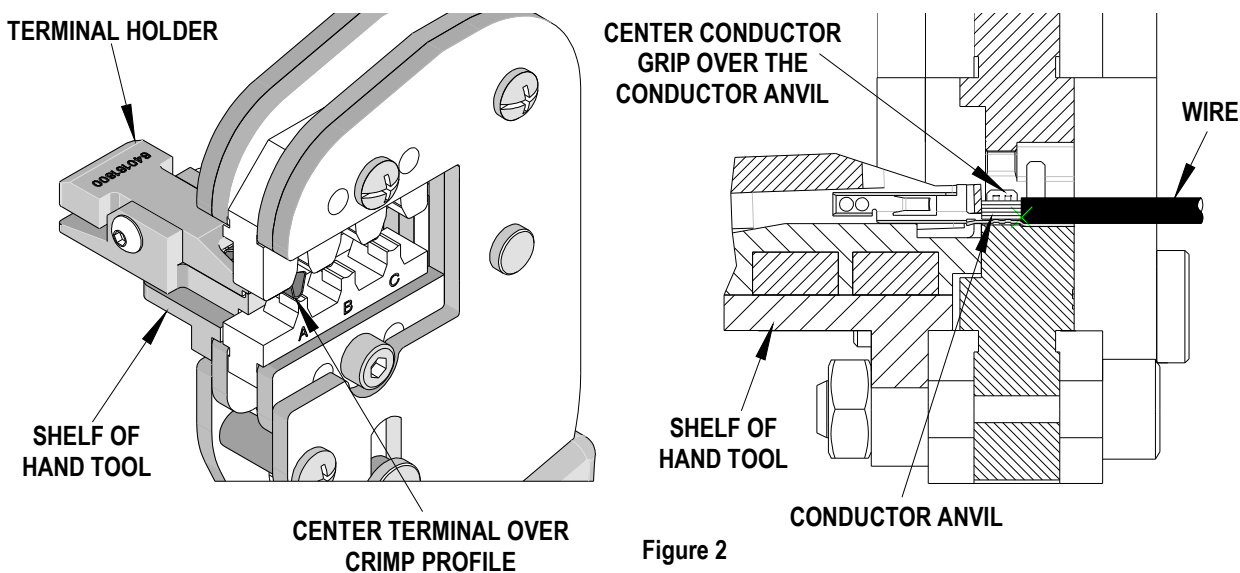

- Carefully place the terminal holder on the shelf of the hand tool and center the terminal as shown over the appropriate tool crimp profile. See Figure 2.

Note: Some terminals may have a large insulation grip; extra care should be taken when loading these terminals into the tool to avoid terminal damage.

- Place a pre-stripped wire into the terminal (see Scope chart for recommended strip lengths). Position the wire so the conductor lies in the conductor grip.
- While holding the wire in place, slowly close the handles of the tool. If excessive resistance is felt, there may be a jam. If this occurs, stop closing the tool and release the anti-backup ratchet by lifting up the lever near the top of the moving handle. See Figure 3.
- Continue to close the tool handles until the anti-backup ratchet releases. Allow the handles to open.
- Remove the crimped terminal and terminal holder from the tool.
- Press down the lever on the terminal holder and remove the crimped terminal.
- Inspect the crimp for loose wire strands, missing crimp, or other damage. Any minor terminal bending may be straightened by hand.

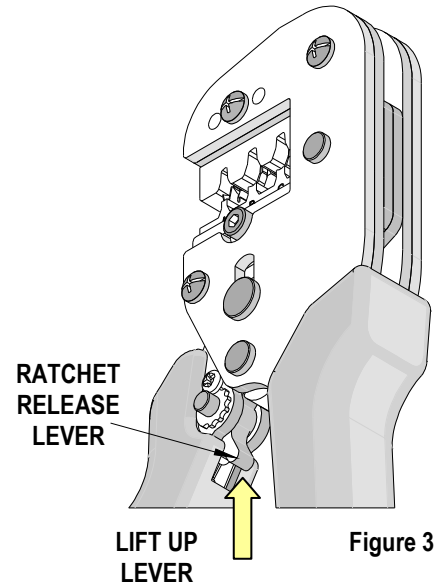

Note:

An occasional, destructive, pull force test with the terminal and wire crimped should be performed to check hand tool crimp. The pull force value must exceed the terminal's minimum pull force specifications listed on page 3. If values do not exceed the minimum pull force when all instructions are followed then a new tool is required.

Maintenance

It is recommended that each operator of the tool be made aware of, and responsible for, the following maintenance steps:

- Remove dust, moisture, and other contaminants with a clean brush, or soft, lint free cloth.
- Do not use any abrasive materials that could damage the tool.
- Make certain all pins; pivot points and bearing surfaces are protected with a thin coat of high quality machine oil. Do not oil excessively. Light oil (such as SAE30W oil) applied at the oil points, shown in Figure 4, every 5,000 crimps or 3 months, is recommended.
- Wipe excess oil from hand tool, particularly from crimping area. Oil transferred from the crimping area onto certain terminations may affect the electrical characteristics of an application.
- When tool is not in use, keep the handles closed to prevent objects from becoming lodged in the crimping dies, and store the tool in a clean, dry area.

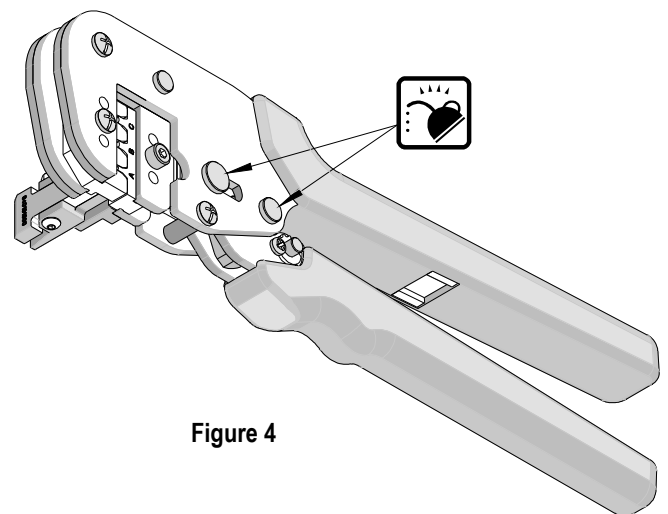

Miscrimps or Jams

If the tool ever becomes jammed in a partially closed position, **DO NOT** force the handles open or closed. The tool will open by lifting the ratchet release lever. See Figure 3.

Tool Handle Preload

Tool handle preload cannot be adjusted.

This hand tool is set to a preload that will fully close the tool jaws without excessive force from the operator. Over the life of the tool the tool linkage can wear and handle preload force may decrease. It is the operator's responsibility to periodically perform a tensile pull test on the crimped wire. If the pull test value falls below specification, the tool should be replaced.

Warranty

This tool is for electrical terminal crimping purposes only. All tools are warranted to be free of manufacturing defects for a period of 30 days. Should such a defect occur, the tool will be exchanged free of charge. This exchange will not be applicable to altered, misused, or damaged tools. This tool is designed for hand use only. Any clamping, fixturing, or use of handle extensions voids this warranty.

CAUTION: Molex crimp specifications are valid only when used with Molex terminals and tooling.

CAUTIONS:

1. Manually powered hand tools are intended for low volume or field repair. This tool is **NOT** intended for production use. Repetitive use of this tool should be avoided.
2. Insulated rubber handles are not protection against electrical shock. **NEVER** perform crimps on active electrical circuits.
3. Wear eye protection at all times.
4. Use only the Molex terminals specified for crimping with this tool.

Certification

Molex does not certify or re-certify ServiceGrade™ hand tools but rather supplies the following guidelines for customers to maintain their hand tools.

- % This tool is qualified to pull force only. To re-certify, crimp a terminal to a wire, which has been stripped 12.7mm (1/2") long, so there is no crimping of the insulation. Pull the terminal and wire at a rate no faster than 25mm (1.00") per minute. See the Molex web site for the Quality Crimp Handbook for more information on pull testing.
- % When the hand tool is no longer capable of achieving minimum pull force, it should be replaced.

Americas Headquarters
Lisle, Illinois 60532 U.S.A.
1-800-78MOLEX
amerinfo@molex.com

Far East North Headquarters
Yamato, Kanagawa, Japan
81-462-65-2324
feninfo@molex.com

Far East South Headquarters
Jurong, Singapore
65-6-268-6868
fesinfo@molex.com

European Headquarters
Munich, Germany
49-89-413092-0
eurinfo@molex.com

Corporate Headquarters
2222 Wellington Ct.
Lisle, IL 60532 U.S.A.
630-969-4550
Fax: 630-969-1352

Visit our Web site at <http://www.molex.com>