

LOW-JITTER SAW OSCILLATOR (SPSO)
OUTPUT : HCSL



Product Number
X1M000461xxxx00

XG5032HAN

- Frequency range : 100 MHz to 200 MHz
- Supply voltage : 2.5 V, 3.3 V
- Output : HCSL
- Function : Output enable (OE)
- External dimensions : 5.0 × 3.2 × 1.4 mm



•Low jitter and low phase noise by SAW unit.

Specifications (characteristics)

Item	Symbol	Specifications	Conditions / Remarks
Output frequency range	f _o	100 MHz to 200 MHz	Please contact us for inquiries regarding available frequencies.
Supply voltage	V _{CC}	C:3.3 V ± 0.33 V, D:2.5 V ± 0.125 V	
Storage temperature	T _{stg}	-55 °C to +125 °C	Store as bare product.
Operating temperature	T _{use}	A: 0 °C to +70 °C, B: -20 °C to +70 °C, D: -5 °C to +85 °C	
Frequency tolerance	f _{tol}	J: ± 50 × 10 ⁻⁶ , L: ± 100 × 10 ⁻⁶	
Current consumption	I _{CC}	35 mA Max.	OE = V _{CC} , with output load
Disable current	I _{dis}	15 mA Max.	OE = GND
Symmetry	SYM	45 % to 55 %	At outputs crossing point
Output voltage	V _{OH}	0.75 V Typ., 0.66 V to 0.85 V	DC characteristics, single output
	V _{OL}	0 V Typ., -0.15 V to 0.15 V	
Crossing voltage	V _{CR}	0.25 V to 0.55 V	
Output load condition	L _{HCSL}	50 Ω	As per measurement circuit below.
	R _s	33 Ω	
	C _L	2 pF	
Input voltage	V _{IH}	70 % V _{CC} Min.	OE terminal
	V _{IL}	30 % V _{CC} Max.	
differential output rise slew rate/ fall slew rate	R _r / R _f	1 V/n to 4 V/ns	Between -0.15 V and 0.15 V of differential output
Start-up time	t _{str}	10 ms Max.	Time at minimum supply voltage to be 0 s
Phase Jitter	t _{pj}	0.3 ps Max.	f _o ≤ 160 MHz
		0.4 ps Max.	160 MHz < f _o ≤ 175 MHz
		0.2 ps Max.	f _o > 175 MHz
Frequency aging	f _{age}	N: ± 10 × 10 ⁻⁶ / year Max.	First year 10 years
		A: Included in Frequency tolerance	

Product Name **XG5032 HAN 100.000000MHz C J A A** (ⓈⓈⓈⓈ: JBA, JDA are not available)

(Standard form)

① Model ② Output(H: HCSL) ③ Frequency

④ Supply voltage (C: 3.3 V Typ., D: 2.5 V Typ.) ⑤ Frequency tolerance ⑥ Operating temperature

⑦ Frequency aging (A: Frequency tolerance include aging, N: Frequency tolerance exclude aging)

Ⓢ Frequency tolerance

J	±50 × 10 ⁻⁶
L	±100 × 10 ⁻⁶

Ⓢ Operating temp.

A	0 °C to +70 °C
B	-20 °C to +70 °C
D	-5 °C to +85 °C

Measurement circuit

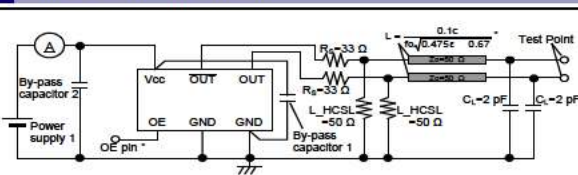

By-pass capacitor 1 (approx. 0.01 μF to 0.1 μF) places closely between V_{CC} and GND.

By-pass capacitor 2 (approx. 10 μF) places closely between power supply terminals on the board.

Output line length L is estimated as follows

$$L = \frac{0.1c}{f_o \sqrt{0.475\epsilon_r + 0.67}}$$

c : Velocity of light in a vacuum
ε_r : Relative dielectric constant of the board
f_o : Output frequency

External dimensions

(Unit:mm)

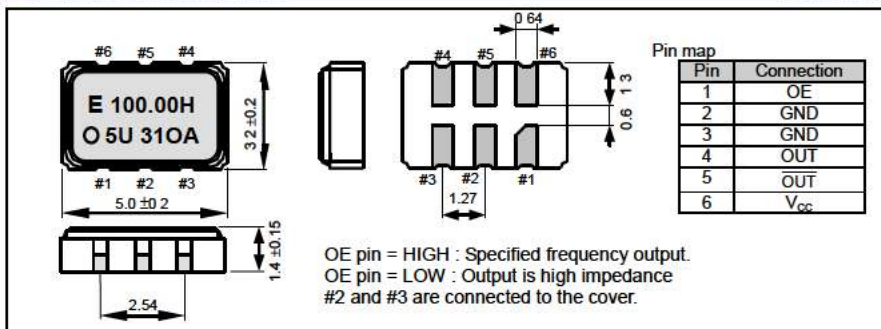

Footprint (Recommended)

(Unit:mm)

