

2-Dimensional Code Reader (Fixed Type) V530-R150E-3, EP-3

Intelligent Light Source and a Two-Camera Unit Respond to a Wide Variety of Applications



Features

Intelligent Light Source

Versatile lighting control and a dome shape that minimizes external interference provide stable images for 2-dimensional code reading.

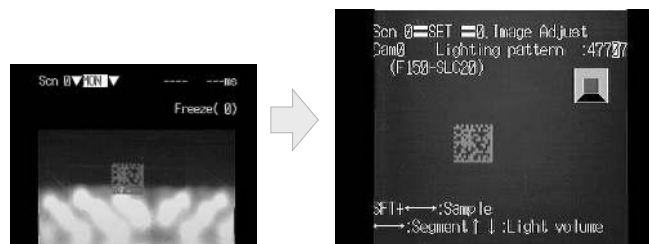

Ring lighting

Intelligent Light Source

Reduces the background effects of metal processed parts.

A Variety of Lighting Methods

The lighting direction and intensity can be changed. In addition, coaxial lighting is available with the F150-SLC20. Optimal lighting methods can be set for a wide variety of workpieces.



Lighting Controlled from Menu

- The lighting block and intensity can be controlled from the Controller menu. Settings can be easily changed without having to touch the light itself.
- Because light is handled as scene data, the lighting conditions can be varied to match model changes on mixed-product lines.
- The Controller manages light settings numerically, for accurate reproducibility.

F150-SLC20 (Field of vision: 20 mm)

The light intensity can be set for each of five lighting blocks, in eight steps.

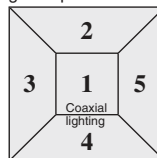

F150-SLC50 (Field of vision: 50)

The light intensity can be set for each of eight lighting blocks, in eight steps.

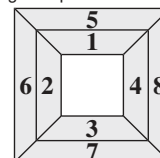

Two-Camera Unit

Two cameras can be switched by a single Controller.



Application Example

Simultaneous Single-Product and Lot Management

Single products and lots can be managed simultaneously.

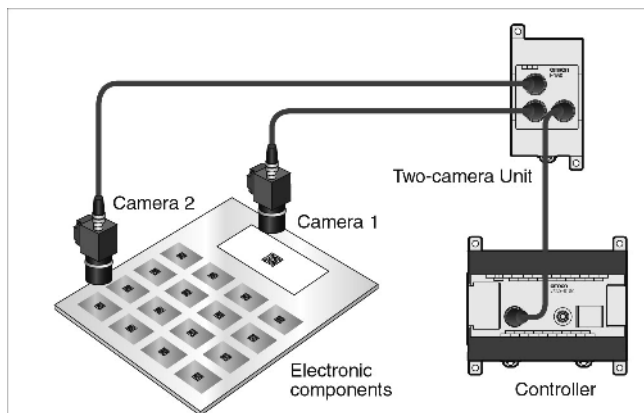

Greater Positioning Tolerance

For applications that cannot be covered by the field of vision of only one camera.

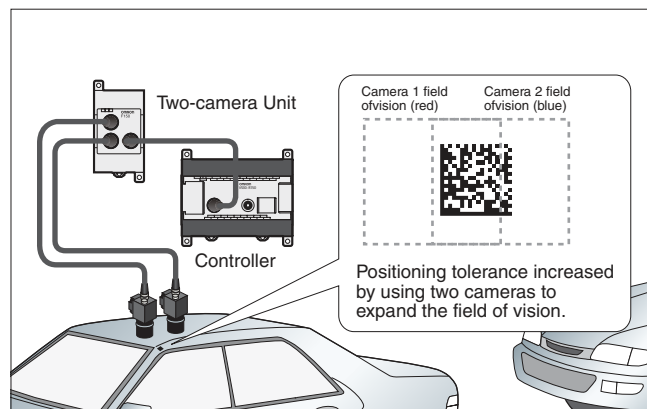

Compatible with Data Matrix Old Version

The V530-R150V3 Controller is also capable of reading the Data Matrix Old Version. (See note.)

Note: Compatible with ECC000, 050, 080, 100, and 140.

Compatible with Data Matrix ECC200, with Up to 64 × 64 Cells

To enable the use of more information, ECC200 codes with up to 64 × 64 cells (max. of 418 alphanumeric characters) can be read.



Max. of 64 alphanumeric characters.

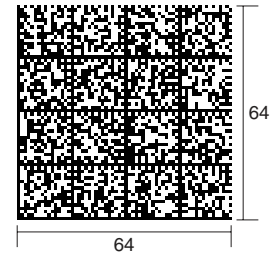

Max. of 418 alphanumeric characters.

New Guidance Function for the Settings Display

The addition of a guidance function on the display greatly simplifies setting.

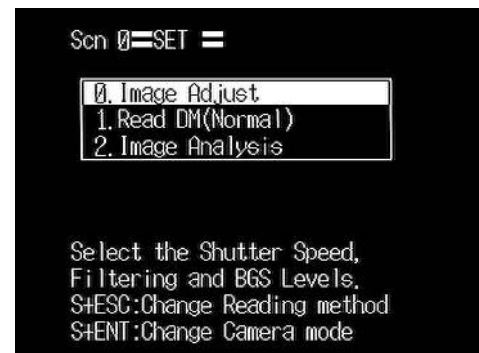

Easy-to-Read Analytical Data Format

See the reading status at a glance on the reading information display. The finder pattern, cell recognition, reading data, etc., can all be viewed on the display.



Finder Pattern (Cutting Symbol)

Use this pattern to detect the 2-dimensional code position. The finder pattern is different for each code.



Easy Image Analysis

The image analysis mode helps to detect the cause of marking problems.



Store up to 24 Defect Images

Use the stored images to confirm defect types.

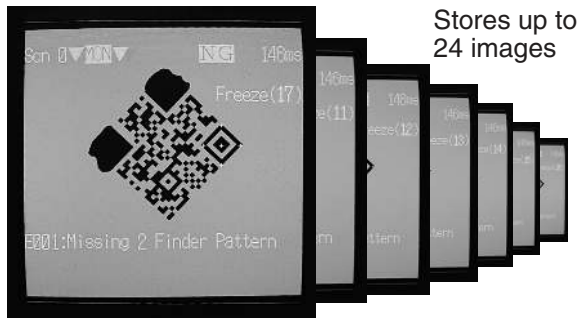

Note: Stored images are kept until the power is turned OFF.

Applications

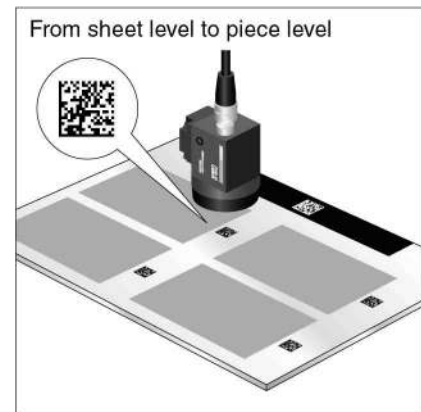
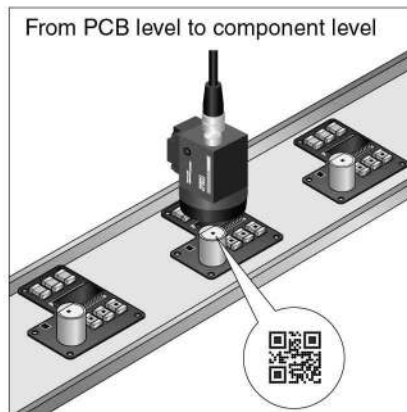
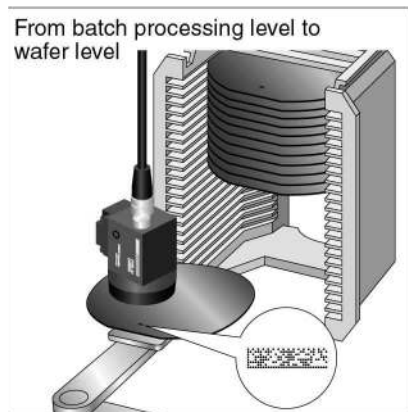

Ordering Information

■ List of Models

Item	Model
Controller	V530-R150E-3, EP-3
Console	F150-KP-2D
Camera	F150-S1A-2D
Camera cable (3 m)	F150-VS-2D
Two-camera unit	F150-A20
Monitor cable (2 m)	F150-VM-2D
Liquid crystal monitor	F150-M05L-2D
Video monitor	F150-M09-2D

Specifications

■ Controller

Item	V530-R150E-3, EP-3
Readable codes	Data Matrix ECC200: 10 × 10 to 64 × 64, 8 × 18, 8 × 32, 12 × 26, 12 × 36, 16 × 36, 16 × 48 Data Matrix Old Ver. (ECC000, 050, 080, 100, 140): 9 × 9 to 25 × 25 QR Code (Model 1, 2): 21 × 21 to 41 × 41 (Version 1 to 6)
Readable direction	360°
Number of pixels (resolution)	512 (H) × 484 (V)
Number of connectable cameras	1 (Using F150-A20: 2 max.)
Number of scenes	10
Image memory function	Maximum of 24 images stored.
Operation method	Menu selectable
Processing method	Gray
Monitor interface	1 channel (over scan monitor)
RS-232C I/F	1 channel
Parallel I/O	3 inputs and 9 outputs including control I/O points
Power supply voltage	20.4 to 26.4 VDC
Degree of protection	IEC 60529: IP 20 (panel mounted)
Current consumption	Approx. 0.5 A
Ambient temperature/humidity	0 to 50°C/35% to 85% (with no condensation)
Weight	Approx. 390 g

■ Camera

Item	F150-S1A-2D	
Camera	Picture element	1/3" CCD
	Effective pixels	659 (H) × 494 (V)
	Shutter function	Electronic frame shutter Shutter speed: 1/100, 1/500, 1/2000, or 1/10000 sec (menu selectable)
Lens	Mounting distance	F150-SLC20: 15 to 25 mm; F150-SLC50: 16.5 to 26.5 mm; F150-SL20A: 61 to 71 mm; F150-SL50A: 66 to 76 mm
	Field of vision	F150-SLC20/SL20A: 20 × 20 mm, F150-SLC50/SL50A: 50 × 50 mm
Light	Light source	F150-SLC20/50: Red LED/Green LED, F150-SL20A/50A: Red LED
	Lighting method	Pulse (synchronized with camera shutter)
Ambient temperature	Operating: 0 to 50°C, storage: -25 to 60°C (with no icing or condensation)	
Ambient humidity	Operating/Storage: 35% to 85% (with no condensation)	
Weight (camera only)	F150-ALC20: Approx. 280 g, F150-FLC50: Approx. 370 g, F150-SL20A/50A: Approx. 135 g, F150-S1A: Approx. 80 g	

■ Two-Camera Unit

Item	F150-A20
Number of connectable cameras	2
Camera mode	2-camera selectable Single, independent (camera 0/1)
Power supply voltage	20.4 to 26.4 VDC
Current consumption	Approx. 0.3 A
Ambient temperature	Operating: 0 to 50°C storage: -25 to 60°C (with no icing or condensation)
Ambient humidity	Operating/Storage: 35% to 85% (with no condensation)
Weight (2-camera unit only)	Approx. 220 g

■ Monitor

Item	Liquid Crystal Monitor	Video Monitor
	F150-M05L-2D	F150-M09-2D
Size	5.5 inches	9 inches
Type	Liquid crystal color TFT	CRT monochrome
Resolution	320 × 240 dots	800 TV lines min. (at center)
Input signal	NTSC composite video (1.0 V/75 Ω)	
Power supply voltage	20.4 to 26.4 VDC	100 to 240 VAC (-15%, +10%)
Current consumption	Approx. 700 mA	Approx. 200 mA
Ambient temperature	Operating: 0 to 50°C storage: -25 to 60°C (with no icing or condensation)	Operating: -10 to 50°C storage: -20 to 65°C (with no icing or condensation)
Ambient humidity	Operating/Storage: 35% to 85% (with no condensation)	10% to 90% (with no condensation)
Weight (monitor only)	Approx. 1 kg	Approx. 4.5 kg

System Configuration

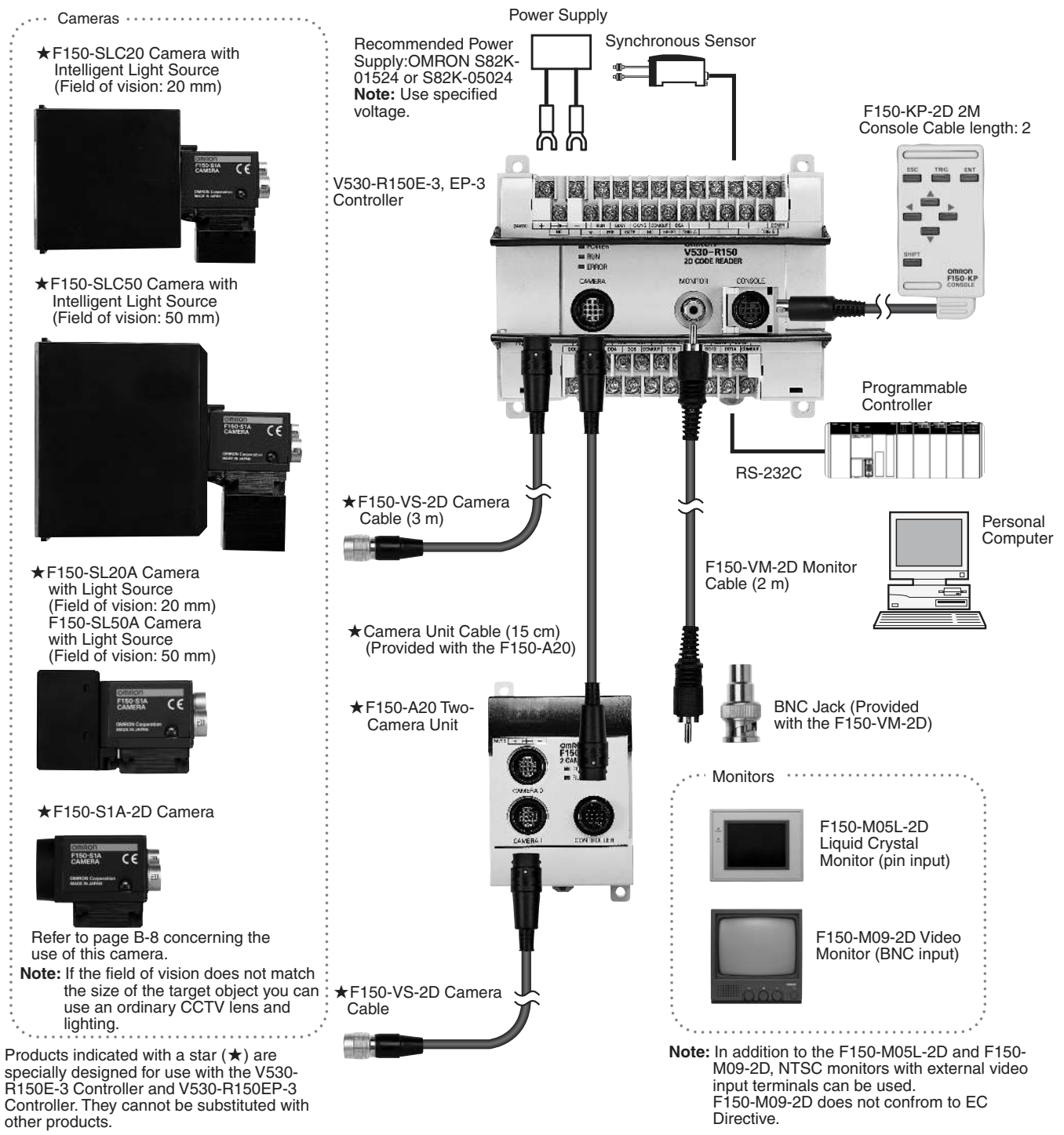

Lighting Methods

Select the appropriate lighting method for the material of the marked object.

Back Lighting

Codes on transparent objects such as glass PCBs can be read by detecting the contrast between transmitted and blocked light.

Applications: Transparent objects such as LCD glass

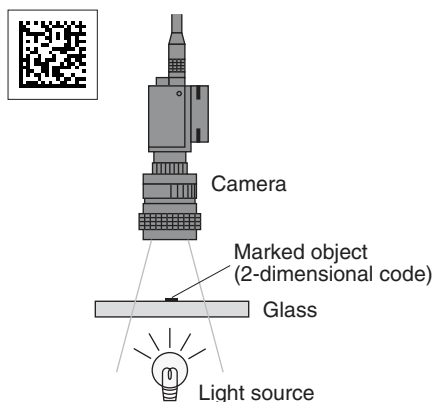

Reflected Lighting

Ring Lighting

For codes printed onto paper or other light-diffusing objects, ring lights can be used to illuminate the marked object. The difference in the reflection factors of the background and the marking enables stable detection.

Applications: Paper labels and corrugated cardboard

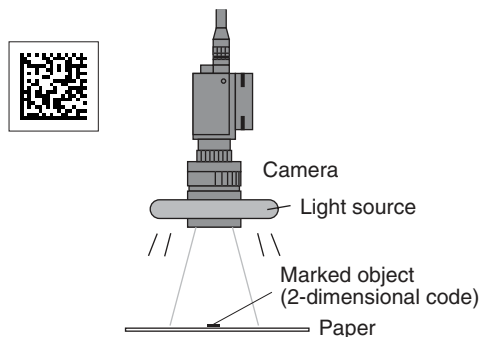

Oblique Lighting

Ring Lighting Close to the Marked Object

For codes inscribed with a laser marker onto PCBs and other relatively glossy surfaces, oblique lighting provides stable detection by distinguishing between regular and diffuse reflected light.

Applications: Direct marking on PCBs and electronic parts

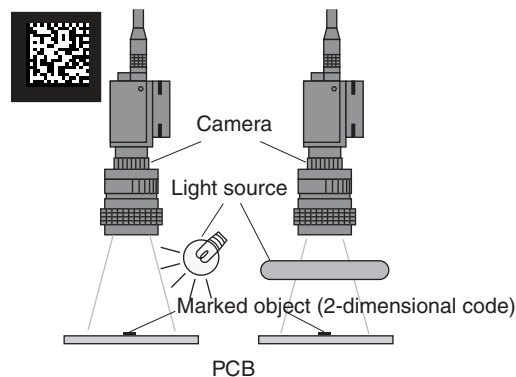

Coaxial Lighting

For codes marked directly onto wafers and other mirror-like surfaces, a stable image with few shadows from surface irregularities can be obtained from the marked object by using coaxial lighting, because it detects only regular reflected light. (The surface of the object must be perpendicular to the optical axis.)

Applications: Mirror-like objects such as wafers

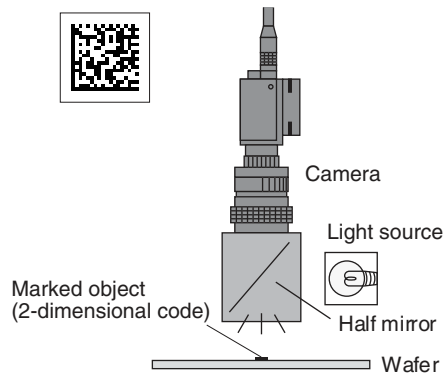

Data Capacity

Data Matrix ECC200

The relation between matrix size (number of cells) and data capacity is shown in the table below. In this example, the matrix size is 12 × 12 cells.

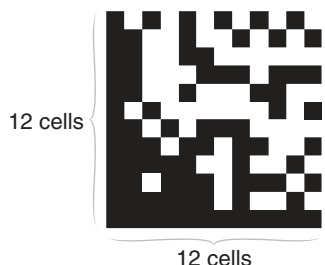

QR Code Model 2

The relation between matrix size (number of cells) and data capacity is shown in the table below. In this example, the matrix size is 21 × 21 cells.

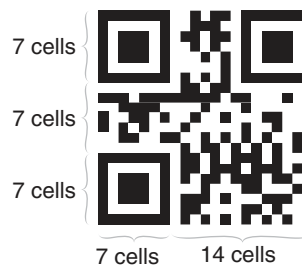

Matrix size	Maximum data capacity				
	Numbers	Alpha-numeric characters	Symbols	Japanese Kanji (Shift JIS)	JIS8
10 × 10	6	3	3	---	1
12 × 12	10	6	5	1	3
14 × 14	16	10	9	3	6
16 × 16	24	16	14	5	10
18 × 18	36	25	22	8	16
20 × 20	44	31	28	10	20
22 × 22	60	43	38	14	28
24 × 24	72	52	46	17	34
26 × 26	88	64	57	21	42
32 × 32	124	91	81	30	60
36 × 36	172	127	113	42	84
40 × 40	228	169	150	56	112
44 × 44	288	214	190	71	142
48 × 48	348	259	230	86	172
52 × 52	408	304	270	101	202
64 × 64	560	418	372	139	278
8 × 18	10	6	5	1	3
8 × 32	20	13	12	4	8
12 × 26	32	22	20	7	14
12 × 36	44	31	28	10	20
16 × 36	64	46	41	15	30
16 × 48	98	72	64	23	47

Matrix size (version)	Error correction	Maximum data capacity			
		Numbers	Alpha-numeric characters (upper case only)	JIS8	Japanese Kanji (Shift JIS)
21 × 21 (version 1)	L (7%)	41	25	17	10
	M (15%)	34	20	14	8
	Q (25%)	27	16	11	7
	H (30%)	17	10	7	4
25 × 25 (version 2)	L (7%)	77	47	32	20
	M (15%)	63	38	26	16
	Q (25%)	48	29	20	12
	H (30%)	34	20	14	8
29 × 29 (version 3)	L (7%)	127	77	53	32
	M (15%)	101	61	42	26
	Q (25%)	77	47	32	20
	H (30%)	58	35	24	15
33 × 33 (version 4)	L (7%)	187	114	78	48
	M (15%)	149	90	62	38
	Q (25%)	111	67	46	28
	H (30%)	82	50	34	21
37 × 37 (version 5)	L (7%)	255	154	106	65
	M (15%)	202	122	84	52
	Q (25%)	144	87	60	37
	H (30%)	106	64	44	27
41 × 41 (version 6)	L (7%)	322	195	134	82
	M (15%)	255	154	106	65
	Q (25%)	178	108	74	45
	H (30%)	139	84	58	36

Note: 1. Maximum Data Capacity

The maximum amount of data that can be stored in a code varies with the code size. In other words, if there is a large amount of data to be stored, then the code size must also be large. The maximum data capacity will also vary with the type of characters used. With a QR Code or Data Matrix, the numeric capacity (numbers only) is larger than the alpha numeric capacity (numbers and letters), which is in turn larger than the Japanese Kanji (Shift JIS) capacity. The order and combinations of different characters also affects the data capacity.

2. The matrix size of a QR Code is indicated by the version. Version 1 indicates that a QR Code contains (the minimum) 21 cells both horizontally and vertically. The larger the version number, the larger the number of cells per side.

Cameras with Light Source

Cameras with Intelligent Light Source

20-mm field of vision	F150-SLC20
50-mm field of vision	F150-SLC50

Note: These models consist of an F150-S1A Camera with Lens and Intelligent Light Source.



Using the Camera with Intelligent Light Source or Camera with Light Source

- The Lens has a fixed focus. Because there is a certain amount of variation in the field of vision and focus of each Lens, the mounting distance must be adjusted each time the Lens or Camera is replaced.
- The camera mounting distance is approximate. Use a mounting method that allows the distance to be adjusted back and forth in the direction of the 2-dimensional code.

2-Dimensional Code Reader Distance vs. Field of Vision

Mount the Camera at a distance that will provide accurate imaging of the 2-dimensional codes.

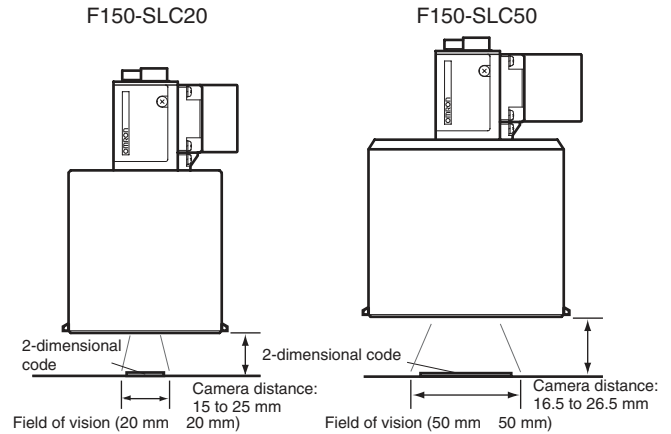

Lenses

CCTV Lenses (Other lenses are available.) See chart on page 11.

Model	F150-LE20	F150-LE50
Dimensions	20 mm dia.	50 mm dia.

Note: Refer to the following optical graph to select the Lens and Extension Tube according to the field of vision and camera mounting distance being used.

Extension Tubes

Model	F150-EXT
Length	A set of six Extension Tubes that are 40, 20, 10, 5, 1, and 0.5 mm in length respectively.

Optical Graph

Point: Based on the necessary field of vision and workpiece, select the Lens and Extension Tube to suit the working distance (WD). Lengthening the Extension Tube lowers the brightness, and increasing distance WD increases the depth of field.

Note: Slight differences exist between cameras. When mounting the Lens, provide a means of adjusting the camera mounting distance.

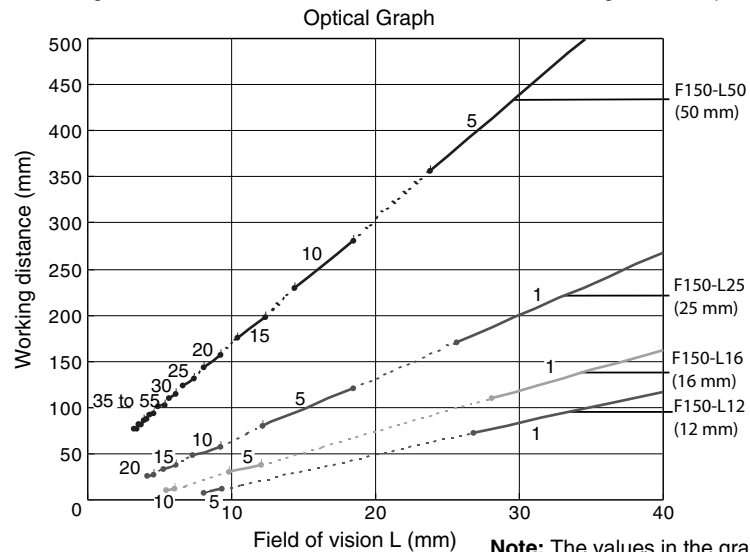

Note: The values in the graph indicate the length (in mm) of the Extension tubes.

Reading the Optical Graph

The X axis of the graph shows field of vision L in millimeters, and the Y axis shows the camera mounting distance A in millimeters.

The curves on the graph indicate different Lenses, and the "t" values indicate the lengths of the Extension Tubes.

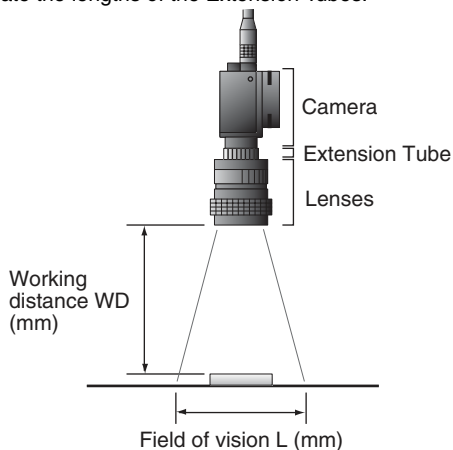

Dimensions

Note: All units are in millimeters unless otherwise indicated.

2-Dimensional Code Reader

V530-R150E-3, V530-R150EP-3

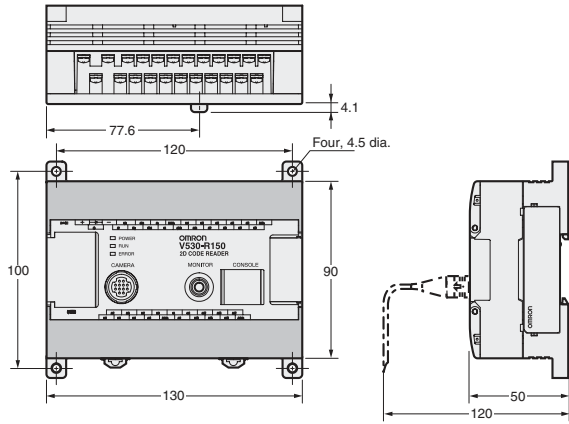

Camera

F150-SLC20
(Camera with F150-LTC20 Intelligent Light Source)

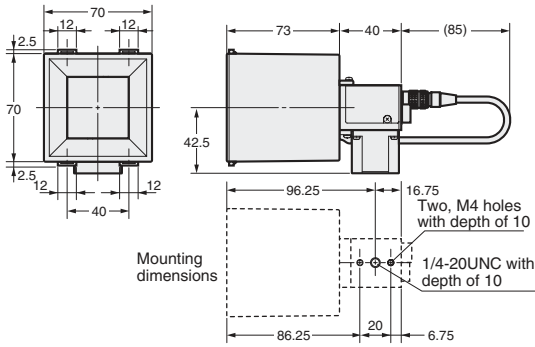

F150-SLC50
(Camera with F150-LTC50 Intelligent Light Source)

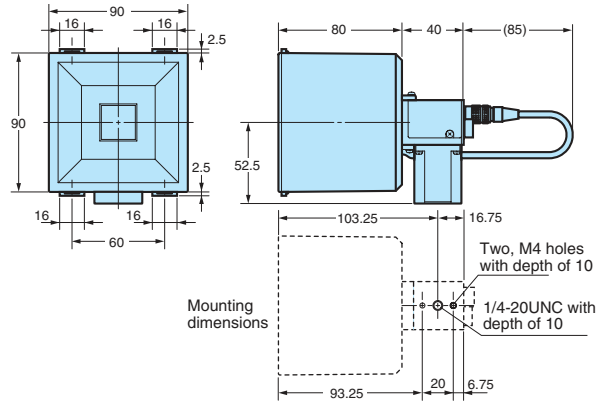

F150-S1A-2D (Camera only)

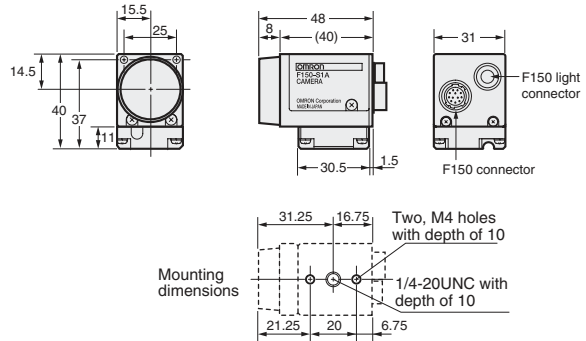

Console

F150-KP-2D

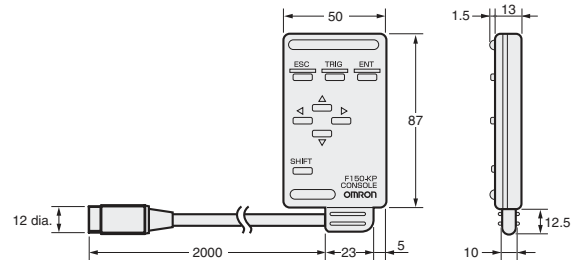

Two-Camera Unit

F150-A20

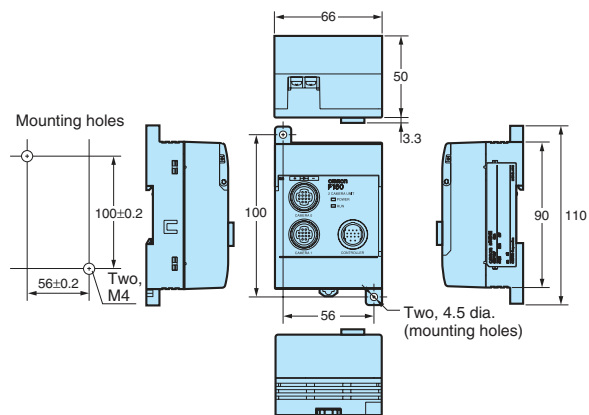

Liquid Crystal Monitor

F150-M05L-2D

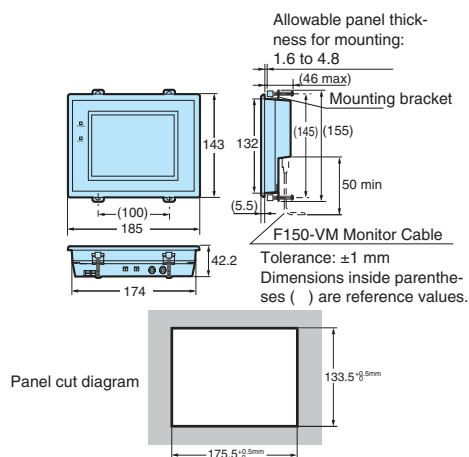

Video Monitor

F150-M09-2D

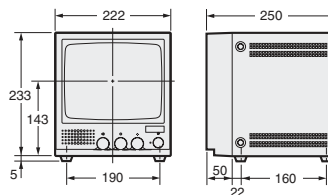

ALL DIMENSIONS SHOWN ARE IN MILLIMETERS.
To convert millimeters into inches, multiply by 0.03937. To convert grams into ounces, multiply by 0.03527.

Terms and Conditions

WARRANTY, LIMITATIONS OF LIABILITY

WARRANTY OMRON's exclusive warranty is that the products are free from defects in materials and workmanship for a period of one year (or other period if specified) from date of sale by OMRON.

OMRON MAKES NO WARRANTY OR REPRESENTATION, EXPRESS OR IMPLIED, REGARDING NON-INFRINGEMENT, MERCHANTABILITY OR FITNESS FOR PARTICULAR PURPOSE OF THE PRODUCTS. ANY BUYER OR USER ACKNOWLEDGES THAT IT ALONE HAS DETERMINED THAT THE PRODUCTS WILL SUITABLY MEET THE REQUIREMENTS OF THEIR INTENDED USE. OMRON DISCLAIMS ALL OTHER WARRANTIES, EXPRESS OR IMPLIED.

LIMITATIONS OF LIABILITY OMRON SHALL NOT BE RESPONSIBLE FOR SPECIAL, INDIRECT OR CONSEQUENTIAL DAMAGES, LOSS OF PROFITS OR COMMERCIAL LOSS IN ANY WAY CONNECTED WITH THE PRODUCTS, WHETHER SUCH CLAIM IS BASED ON CONTRACT, WARRANTY, NEGLIGENCE OR STRICT LIABILITY.

In no event shall responsibility of OMRON for any act exceed the individual price of the product on which liability is asserted.

IN NO EVENT SHALL OMRON BE RESPONSIBLE FOR WARRANTY, REPAIR OR OTHER CLAIMS REGARDING THE PRODUCTS UNLESS OMRON'S ANALYSIS CONFIRMS THAT THE PRODUCTS WERE PROPERLY HANDLED, STORED, INSTALLED AND MAINTAINED AND NOT SUBJECT TO CONTAMINATION, ABUSE, MISUSE, OR INAPPROPRIATE MODIFICATION OR REPAIR.

APPLICATION CONSIDERATIONS

SUITABILITY FOR USE OMRON shall not be responsible for conformity with any standards, codes or regulations which apply to the combination of the product in the customer's application or use of the product.

At the customer's request, OMRON will provide applicable third party certification documents identifying ratings and limitations of use which apply to the product. This information by itself is not sufficient for a complete determination of the suitability of the product in combination with the end product, machine, system, or other application or use.

The following are some examples of applications for which particular attention must be given. This is not intended to be an exhaustive list

of all possible uses of this product, nor is it intended to imply that the uses listed may be suitable for this product:

- Outdoor use, uses involving potential chemical contamination or electrical interference, or conditions or uses not described in this catalog.
- Nuclear energy control systems, combustion systems, railroad systems, aviation systems, medical equipment, amusement machines, vehicles, safety equipment, and installations subject to separate industry or government regulations.
- Systems, machines and equipment that could present a risk to life or property.

Please know and observe all prohibitions of use applicable to this product.

NEVER USE THE PRODUCT FOR AN APPLICATION INVOLVING SERIOUS RISK TO LIFE OR PROPERTY WITHOUT ENSURING THAT THE SYSTEM AS A WHOLE HAS BEEN DESIGNED TO ADDRESS THE RISKS, AND THAT THE OMRON PRODUCT IS PROPERLY RATED AND INSTALLED FOR THE INTENDED USE WITHIN THE OVERALL EQUIPMENT OR SYSTEM.

PROGRAMMABLE PRODUCTS OMRON shall not be responsible for the user's programming of a programmable product, or any consequence thereof.

DISCLAIMERS

PERFORMANCE DATA Performance data given in this catalog is provided as a guide for the user in determining suitability and does not constitute a warranty. It may represent the result of OMRON's test conditions, and the user must correlate it to actual application requirements. Actual performance is subject to the OMRON Warranty and Limitations of Liability.

CHANGE IN SPECIFICATIONS Product specifications and accessories may be changed at any time based on improvements and other reasons. It is our practice to change part numbers when published ratings or features are changed, or when significant construction changes are made. However, some specifications of the product may be changed without any notice. When in doubt, special part numbers may be assigned to fix or establish key specifications for your application. Please consult with your OMRON representative at any time to confirm actual specifications of purchased product.

ERRORS AND OMISSIONS The information in this catalog has been carefully checked and is believed to be accurate; however, no responsibility is assumed for clerical, typographical or proofreading errors, or omissions.

Complete terms and conditions for product purchase and use are on Omron's website at www.omron.com/oei – under the "About Us" tab, in the Legal Matters section.

ALL DIMENSIONS SHOWN ARE IN MILLIMETERS. To convert millimeters into inches, divide by 25.4

OMRON®

OMRON ELECTRONICS LLC

One Commerce Drive
Schaumburg, IL 60173

847-843-7900

For US technical support or other inquiries:

800-556-6766

OMRON CANADA, INC.

885 Milner Avenue
Toronto, Ontario M1B 5V8

416-286-6465

OMRON ON-LINE

Global - <http://www.omron.com>
USA - <http://www.omron.com/oei>
Canada - <http://www.omron.ca>