



**SINGLE SUPPLY QUAD
PECL/TTL-TO-PECL**

**Precision Edge®
SY100S815**



Precision Edge®

- Quad PECL version of popular ECLinPS E111
- Low skew
- Guaranteed skew spec
- TTL enable input
- Selectable TTL or PECL clock input
- Single +5V supply
- Differential internal design
- PECL I/O fully compatible with industry standard
- Internal 75kΩ PECL input pull-down resistors
- Available in 16-pin SOIC package

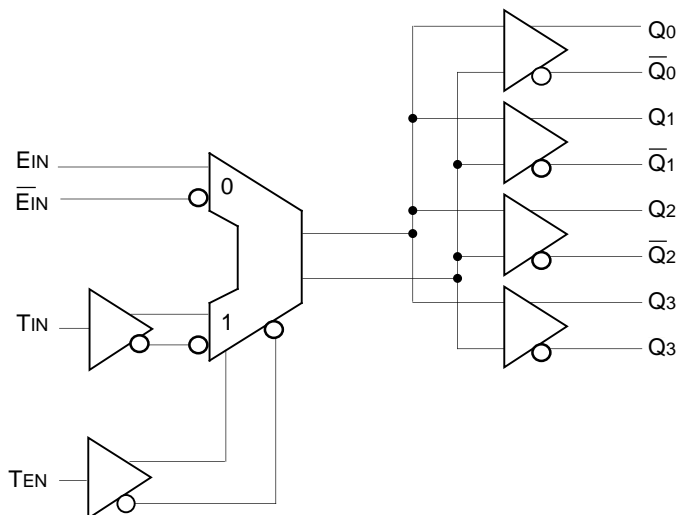

The SY100S815 is a low skew 1-to-4 PECL differential driver designed for clock distribution in new, high-performance PECL systems. It accepts either a PECL clock input or a TTL input by using the TTL enable pin T_{EN} . When the TTL enable pin is HIGH, the TTL input is enabled and the PECL input is disabled. When the enable pin is set LOW, the TTL input is disabled and the PECL input is enabled.

The device is specifically designed and produced for low skew. The interconnect scheme and metal layout are carefully optimized for minimal gate-to-gate skew within the device. Wafer characterization and process control ensure consistent distribution of propagation delay from lot to lot. Since the S815 shares a common set of "basic" processing with the other members of the ECLinPS family, wafer characterization at the point of device personalization allows for tighter control of parameters, including propagation delay.

To ensure that the skew specification is met, it is necessary that both sides of the differential output are terminated into 50Ω , even if only one side is being used. In most applications, all nine differential pairs will be used and, therefore, terminated. In the case where fewer than nine pairs are used, it is necessary to terminate at least the output pairs on the same package side (i.e. sharing the same V_{CC} as the pair(s) being used on that side) in order to maintain minimum skew.

Pin	Function
E_{IN}, \bar{E}_{IN}	Differential PECL Input Pair
T_{IN}	TTL Input
T_{EN}	TTL Input Enable
$Q_0, \bar{Q}_0 - Q_3, \bar{Q}_3$	Differential PECL Outputs
V_{CC}	PECL Vcc (+5.0V)
V_{EE}	PECL Ground (0V)

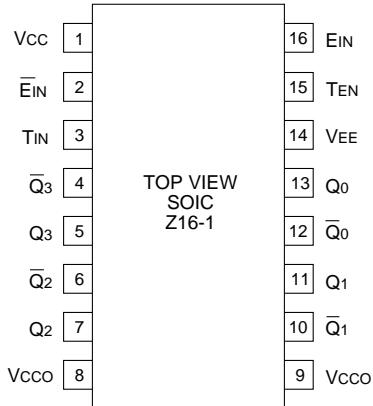

16-Pin SOIC (Z16-1)

Ordering Information

Part Number	Package Type	Operating Range	Package Marking	Lead Finish
SY100S815ZC	Z16-1	Commercial	SY100S815ZC	Sn-Pb
SY100S815ZCTR ⁽¹⁾	Z16-1	Commercial	SY100S815ZC	Sn-Pb
SY100S815ZG ⁽²⁾	Z16-1	Industrial	SY100S815ZG with Pb-Free bar-line indicator	NiPdAu Pb-Free
SY100S815ZGTR ^(1, 2)	Z16-1	Industrial	SY100S815ZG with Pb-Free bar-line indicator	NiPdAu Pb-Free

Notes:

1. Tape and Reel.
2. Pb-Free package is recommended for new designs.

TEN	EIN	TIN	Q
L	L	X	L
L	H	X	H
H	X	L	L
H	X	H	H

VCC = VCCO = +5.0V ± 5%

Symbol	Parameter	TA = 0°C			TA = +25°C			TA = +85°C			Unit
		Min.	Typ.	Max.	Min.	Typ.	Max.	Min.	Typ.	Max.	
I _{IH}	Input HIGH Current	—	—	150	—	—	150	—	—	150	μA
I _{IL}	Input LOW Current	0.5	—	—	0.5	—	—	0.5	—	—	μA
V _{IH}	Input HIGH Voltage ⁽¹⁾	3.835	—	4.120	3.835	—	4.120	3.835	—	4.120	V
V _{IL}	Input LOW Voltage ⁽¹⁾	3.190	—	3.525	3.190	—	3.525	3.190	—	3.525	V
V _{OH}	Output HIGH Voltage ⁽²⁾	V _{CC} -1025	V _{CC} -955	V _{CC} -870	V _{CC} -1025	V _{CC} -955	V _{CC} -870	V _{CC} -1025	V _{CC} -955	V _{CC} -870	mV
V _{OL}	Output LOW Voltage ⁽²⁾	V _{CC} -1890	V _{CC} -1705	V _{CC} -1620	V _{CC} -1890	V _{CC} -1705	V _{CC} -1620	V _{CC} -1890	V _{CC} -1705	V _{CC} -1620	mV
I _{CC}	Power Supply ⁽³⁾ Current	—	53	65	—	53	65	—	60	74	mA

Notes:

- V_{CC} = V_{CCO} = 5.0V
- V_{IN} = V_{IH} (Max.) or V_{IL} (Min.) Loading with 50Ω to V_{CC} -2V.
- All inputs and outputs open.

VCC = VCCO = +5.0V ± 5%

Symbol	Parameter	TA = 0°C			TA = +25°C			TA = +85°C			Unit	Condition
		Min.	Typ.	Max.	Min.	Typ.	Max.	Min.	Typ.	Max.		
V _{IH}	Input HIGH Voltage	2.0	—	—	2.0	—	—	2.0	—	—	V	
V _{IL}	Input LOW Voltage	—	—	0.8	—	—	0.8	—	—	0.8	V	
I _{IH}	Input HIGH Current ^(1, 2)	—	—	20	—	—	20	—	—	20	μA	
I _{IL}	Input LOW Current ⁽³⁾	—	—	-0.6	—	—	-0.6	—	—	-0.6	mA	
V _{IK}	Input Clamp Voltage ⁽⁴⁾	—	—	-1.2	—	—	-1.2	—	—	-1.2	V	

Notes:

- V_{IN}=2.7V
- V_{IN}=5.0V
- V_{IN}=0.5V
- I_{IN}=-18mA

VCC = VCCO = +5.0V ± 5%

Symbol	Parameter	TA = 0°C			TA = +25°C			TA = +85°C			Unit
		Min.	Typ.	Max.	Min.	Typ.	Max.	Min.	Typ.	Max.	
tPLH	Propagation Delay to Output ⁽¹⁾										ps
tPHL	EIN (differential) ⁽²⁾	430	—	630	430	—	630	430	—	630	
	EIN (single-ended) ⁽³⁾	330	—	730	330	—	730	330	—	730	
	TIN	350	—	950	350	—	950	350	—	950	
t _{skew}	Within-Device skew ⁽⁴⁾	—	25	50	—	25	50	—	25	50	ps
V _{PP}	Minimum PECL ⁽⁵⁾ Input Swing	250	—	—	250	—	—	250	—	—	mV
V _{CMR}	PECL Common ⁽⁶⁾ Mode Range	-1.6	—	-0.4	-1.6	—	-0.4	-1.6	—	-0.4	V
t _r	Output Rise/Fall Times	275	375	600	275	375	600	275	375	600	ps
t _f	20% to 80%										

Notes:

1. Part-to-part skew is defined as Max. — Min. value at the given temperature.
2. The differential propagation delay is defined as the delay from the crossing points of the differential input signals to the crossing point of the differential output signals.
3. The single-ended propagation delay is defined as the delay from the 50% point of the input signal to the 50% point of the output signal.
4. The within-device skew is defined as the worst case difference between any two similar delay paths within a single device.
5. V_{PP} (min.) is defined as the minimum input differential voltage which will cause no increase in the propagation delay. The V_{PP} (min.) is AC limited for the S815, as a differential input as low as 50mV will still produce full PECL levels at the output.
6. V_{CMR} is defined as the range within which the V_{IH} level may vary, with the device still meeting the propagation delay specification. The V_{IL} level must be such that the peak-to-peak voltage is less than 1.0V and greater than or equal to V_{PP} (min.).

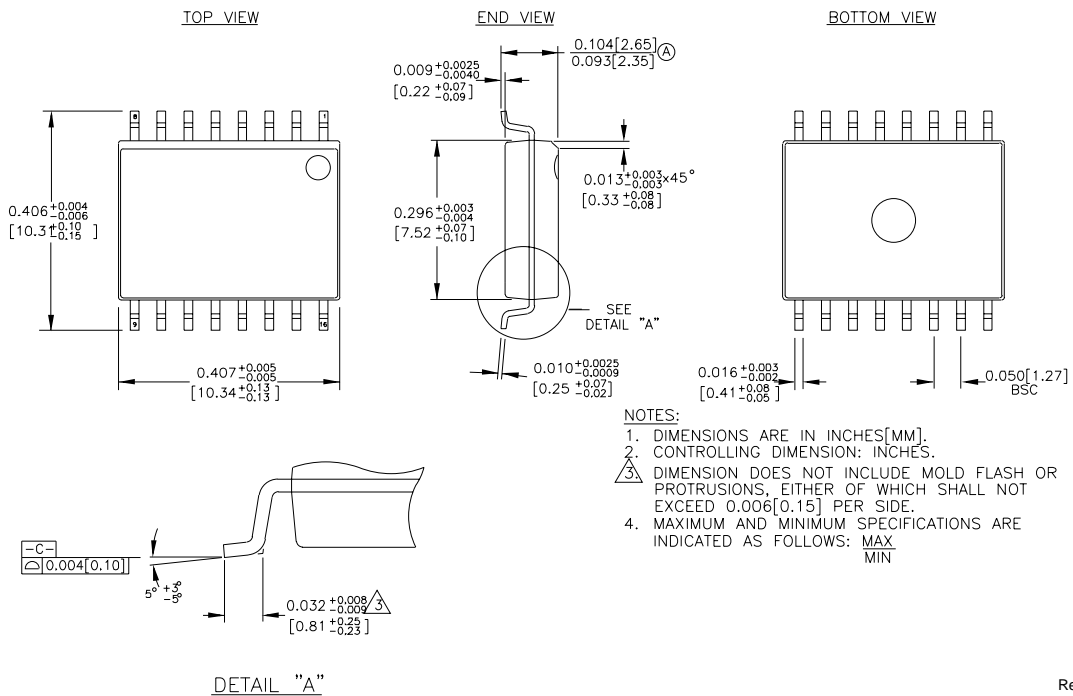

Rev. 03

MICREL, INC. 2180 FORTUNE DRIVE SAN JOSE, CA 95131 USA

TEL + 1 (408) 944-0800 FAX + 1 (408) 474-1000 WEB <http://www.micrel.com>

The information furnished by Micrel in this datasheet is believed to be accurate and reliable. However, no responsibility is assumed by Micrel for its use. Micrel reserves the right to change circuitry and specifications at any time without notification to the customer.

Micrel Products are not designed or authorized for use as components in life support appliances, devices or systems where malfunction of a product can reasonably be expected to result in personal injury. Life support devices or systems are devices or systems that (a) are intended for surgical implant into the body or (b) support or sustain life, and whose failure to perform can be reasonably expected to result in a significant injury to the user. A Purchaser's use or sale of Micrel Products for use in life support appliances, devices or systems is at Purchaser's own risk and Purchaser agrees to fully indemnify Micrel for any damages resulting from such use or sale.

© 2006 Micrel, Incorporated.