

**RIGHT ANGLE PLUG CRIMP TYPE
CABLE 5/50 S**

R141.182.161
SERIES BNC-COM

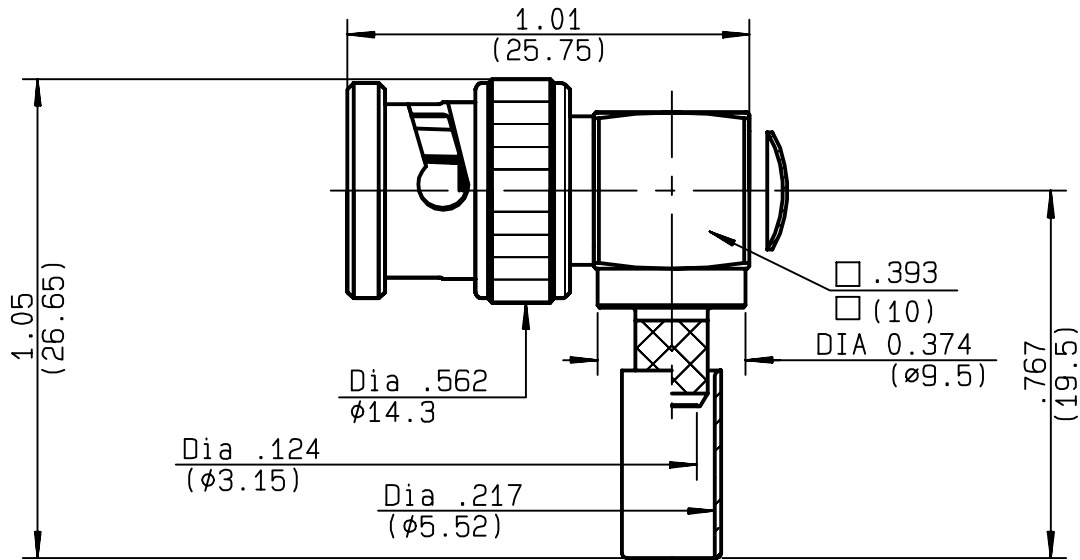

NOMINAL IMPEDANCE	50 Ω
FREQUENCY RANGE	0-1.5 GHz
TEMPERATURE RATING	-35/+70 °C
V.S.W.R	1.35 + x F(GHz)Maxi
RF INSERTION LOSS	0.175 √F(GHz) dB Maxi
VOLTAGE RATING	500 Veff Maxi
DIELECTRIC WITHSTANDING VOLTAGE	1500 Veff Mini
INSULATION RESISTANCE	5000 MΩMini
HERMETIC SEAL	NA Atm.cm ³ /s
LEAKAGE (pressurized only)	NA
MECHANICAL DURABILITY	100 Cycles
WEIGHT	15.1 gr
SPECIFICATION	

CABLES : KX 15	
RG 141	
RG 58	
OTHERS CHARACTERISTICS	
CABLE RETENTION	90 N Mini
CENTER CONTACT RETENTION	
Axial force - mating end	15 N Mini
Axial force - opposite end	15 N Mini
Torque	NA cm.N Mini
RECOMMENDED TORQUES	
Mating	NA cm.N
Panel nut	NA cm.N
Clamp nut	NA cm.N

CONNECTOR PARTS	MATERIALS	FINISH	(all values are given) in micrometers
BODY	BRASS	NICKEL 2	
OUTER CONTACT			
CENTER CONTACT	BRASS	GOLD 0.2 OVER NICKEL 2	
INSULATOR	WHITE POLYPROPYLENE	-	
GASKET	SILICONE RUBBER	-	
OTHERS PIECES			

ISSUE 9945B02	CREATION DATE 31/05/1990	FILE PART-NUMBER 90-1200-031
-------------------------	------------------------------------	--



Connect to the future

The information given here is subject to change without notice.
Design changes may be in order to improve the product .

LELEU



R141.182.161

ISSUE **9945B02** SERIES **BNC-COM**

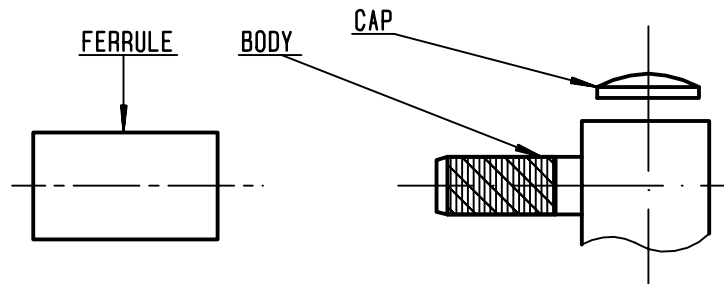

①

Slide onto the cable the ferrule .
Strip the cable .

-
-

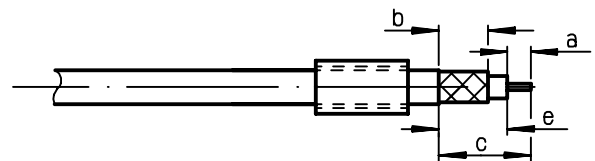

Stripping	a	b	c	d	e
inch	0.079	0.295	0.63	0	0.551
mm	2	7.5	16		14

②

Fan the braid .
Push connector body under the braid .
Slide the ferrule on the braid
(in direction F)

-
-

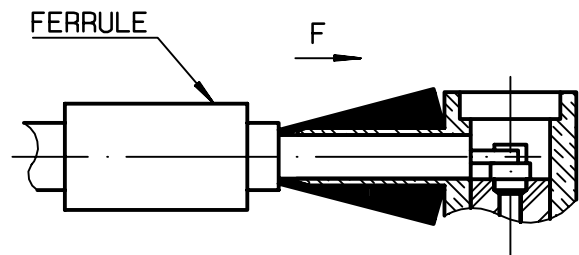

③

Crimp the ferrule with crimping tool
R282 223 000 (Hex. : .213) or
crimping tool R 282 293 000 (M22520/5-01)
+ dies R 282 235 011 (M22520/5-11)
Solder inner conductor .

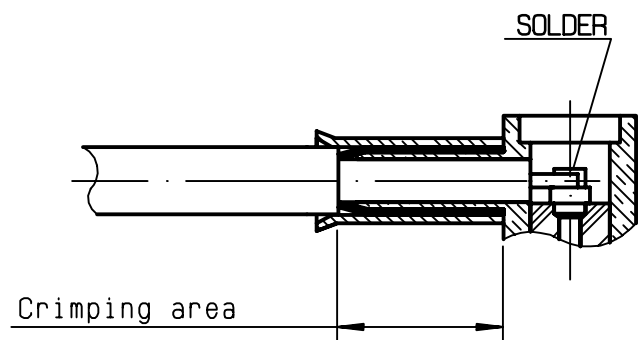

④

Place the cap .
Press cap flush or slightly below surface
of body assembly .

-
-
-
-
-

